

MITSUBISHI GRAPHIC ARTS SYSTEM

Silver Master System  
**CP-610S**  
Instruction Manual

MITSUBISHI

**NOTE**

This equipment has been tested and found to comply with the limits for a Class A digital device, pursuant to Part 15 of the FCC Rules. These limits are designed to provide reasonable protection against harmful interference when the equipment is operated in a commercial environment. This equipment generates, uses, and can radiate radio frequency energy and, if not installed and used in accordance with the instruction manual, may cause harmful interference to radio communications. Operation of this equipment in a residential area is likely to cause harmful interference in which case the user will be required to correct the interference at his own expense.

**Read this manual before using the CP-610S.**

In particular, to ensure correct and safe use of the CP-610S, please read the section below concerning "Point To Note".

**Point To Note:**

- (1) Please read and thoroughly understand this manual before using this unit. If you have any questions, contact a Mitsubishi agent or distributors where you purchased the unit.
- (2) Make sure that the CP-610S is connected to a power supply with an earth leakage breaker. The output rating is written on the name plate.  
The working current should be 30mA.  
Power supply connections should be handled by a qualified electrician.
- (3) Make sure that the earth wire (green/yellow-spiral wire) of the power supply cable should be grounded.  
This connection must be connected by a qualified electrician.
- (4) The chemical used may be harmful to the eyes and skin. Read the instructions on the labels of the chemicals before using.
- (5) When removing the covers of the main unit, turn the original power switch (user) and the power switch of the main unit OFF. The electronic components inside may cause an electric shock.
- (6) When replacing a fuse, make sure that you replace it with a fuse of the same rating, otherwise a fire may occur.
- (7) Do not look directly at the lamp when the light source lamp is lit. If you experience eye irritation, seek appropriate treatment from a specialist.
- (8) Precautions when replacing lamp:
  - (a) Turn the power switch of the main unit OFF.
  - (b) Turn the original power switch (user) OFF.
  - (c) Prepare the same type lamp as the one currently in use, and check the voltage indication.
  - (d) Replace the lamp after it has cooled (after 5 or more minutes have elapsed)
- (9) This unit has motors with built-in thermal overload protectors. These motors automatically restart, so make sure that the original power switch (user) and power switch of the main unit are turned OFF.
- (10) To extend the length of the power cord consult a service personnel or an agent.
- (11) If you discover that the power cord insulation sheath is ripped or frayed, stop operation, and contact a service personnel for repairs.
- (12) Take ample precautions when wiring. If the power cord is exposed near a table or counter, it may be damaged or may contact an individual when a power short occurs.
- (13) Do not step on or strongly pull the power cord.
- (14) Be especially careful during operation when a child is near the unit.

# CONTENTS

1.	Introduction .....	1
2.	Specifications .....	2
3.	Overview .....	3
4.	Drawing of Process .....	4
5.	Precautions When Using .....	5
6.	Installation Conditions .....	6
7.	Names and Functions of Parts .....	7
7-1	Configuration .....	7
7-2	Names of Parts .....	8
7-2-1	Power Switch .....	8
7-2-2	Control Panel .....	9
7-3	Original Setting Section .....	16
7-3-1	Setting Original .....	16
7-3-2	Positioning of Original .....	16
7-4	Lens/Mirror Section .....	17
7-5	Master Magazine Section .....	18
7-5-1	How to Set the Master .....	18
7-5-2	Master End .....	19
7-5-3	Master Splice Detection .....	19
7-6	Base Solution Tank Section .....	20
7-6-1	Preparation of Processing Solution .....	20
7-6-2	Developer Tank [Capacity: 10 liters] .....	20
7-6-3	Stabilizer Tank [Capacity: 10 liters] .....	20
7-6-4	Control of Processing Solution .....	21
7-7	Waste fluid Tank Section .....	22
8.	Control of Processing Solutions .....	23
8-1	Replenishing and Draining Processing Solutions .....	23
8-2	Control of Rinse BathTub .....	26
9.	Exposing .....	27
9-1	Exposing Procedure .....	27
9-2	How To Determine the Standard Exposure .....	28
9-3	How to Determine the Optimum Exposure Level .....	29

10. Photographing Method .....	30
11. Maintenance .....	50
11-1 Maintenance Mode .....	50
11-2 General Care .....	52
11-2-1 Cleaning Processor Section .....	52
11-2-2 Replacing the Cutter Blade .....	53
11-2-3 Replacing Halogen Lamp .....	54
11-2-4 Taking Care of the Copy glass .....	55
11-2-5 Taking Care of the Lens and Mirror Section .....	56
11-2-6 Cleaning the Base Solution Tank Filter .....	56
11-2-7 Cleaning the Back Filter .....	57
11-3 Lubrication .....	57
11-4 Fuse Locations .....	58
11-5 Ordering Parts .....	58
12. Troubleshooting .....	59
12-1 Error Messages .....	59

# 1. Introduction

Thank you very much for purchasing the CP-610S Silver Master. The CP-610S is a machine designed for use in reproduction that has various automatic systems for controlling exposure, can select reproduction positions by micro-computer, and can be widely used from A4 size to "A2W" size plates (610 × 820 mm / 24 1/64" × 32 1/4").

Please thoroughly read this instruction manual to ensure the superb performance of the CP-610S.

See the "Silver Master Technical Guide" for information on printing methods.

## 2. Specifications

No.	Item	Content
1	Master	Number of Rolls: 1 SLM-R11, SLM-F
2	Master Width (cm)	22.9 (9"), 25.4 (10"), 27.9 (11"), 30.5 (12"), 31.0 (12 1/5") 32.4 (12 3/4"), 37.0 (14 9/16"), 40.4 (15 7/8"), 41.4 (16 3/10") 50.8 (20"), 55.0 (21 21/32"), 57.0(22 7/16"), 61.0 (24 1/64")
3	Master Cut Length (cm)	37.0 to 82.0 (1 mm unit settings)
4	Effective Photographing Size (cm)	55.0 × 79.0 (21 21/32" × 31 3/32")
5	Maximum Output Size (cm)	61.0 × 82.0 (24 1/64" × 32 1/4")
6	Maximum Original Layout Sheet Size (cm)	65.5 × 84.0 (25 25/32" × 33 1/16")
7	Magnification	100% (Fixed at Full Scale)
8	Light Source	Halogen Lamp 1
9	Control Panel	Flat panel interactive
10	Original Set	Original surface down, with 400 m/m pin bar
11	Photographic Type	Original, master shift slit exposure type
12	Divided Exposure	Automatic double exposure, automatic multiple exposure, multiple exposure
13	Exposure Control	Power supply thyristor type Digital illuminance adjustment: 0 to 99
14	Cutter	Slide cut type
15	Master Splice Detection Device	Display, alarm buzzer, automatic overcut
16	Master Heating	60 W heater, thermo-control type
17	Processor	Reduced solution tank system
18	Tub Capacity	Developer: 310 cc, Stabilizer: 640 cc
19	Base Solution Tank Capacity	Developer: 10 liters (2.63 US gal.), Stabilizer: 10 liters (2.63 US gal.)
20	Cistern Tank Capacity	Developer: 570 cc, Stabilizer: 570 cc
21	Solution Temperature Control	Tub 80 W heater: 29.5°C, ±1.5 (85.1°F ±2.7) Cistern tank 80 W heater: 29°C ±3 (84.2°F ±5.4)
22	Rinse Bath Capacity	<del>580 cc</del> , replenisher tank: 1 liters (0.26 US gal.)
23	Dryer	<del>5cc</del> 1000 W fan heater (top), 275 W heater (bottom), thermo-control type
24	Initial Plate Time	1 min. 44 sec. (66.0 cm feed)
25	Cycle Time	50 sec. (66.0 cm feed)
26	Electric Capacity	1 phase, 200 ~ 240 V, 3.8 kW
27	Main Unit Dimensions (W × D × H)	197.5 × 92.0 × 110.0 (cm) 77 3/4" × 36 7/32" × 43 5/16" (inch)
28	Weight (without processing solution)	245 kg. 540 Lb.

### 3. Overview

#### Overview

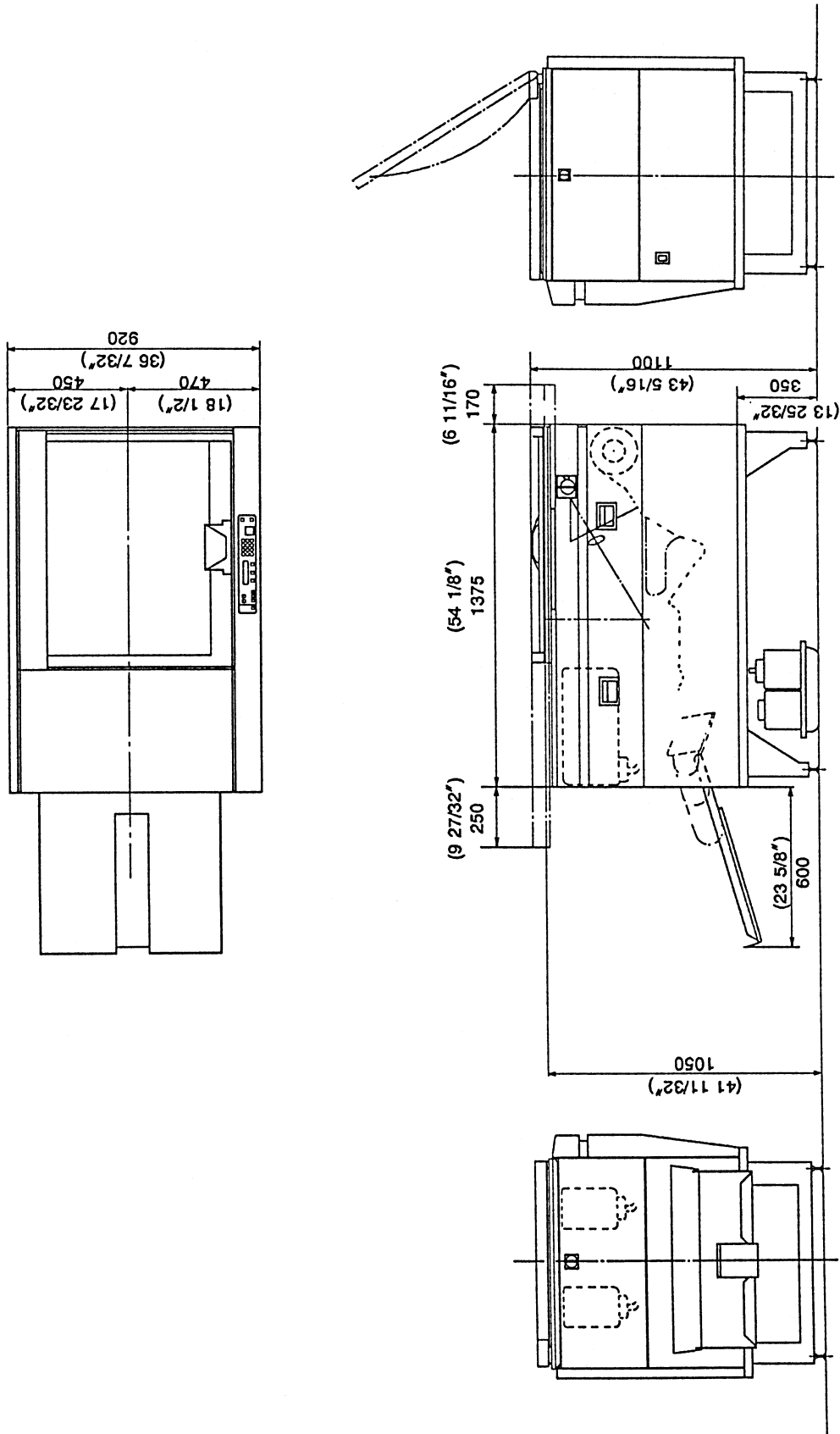



# 4. Drawing of Process

Drawing of Process

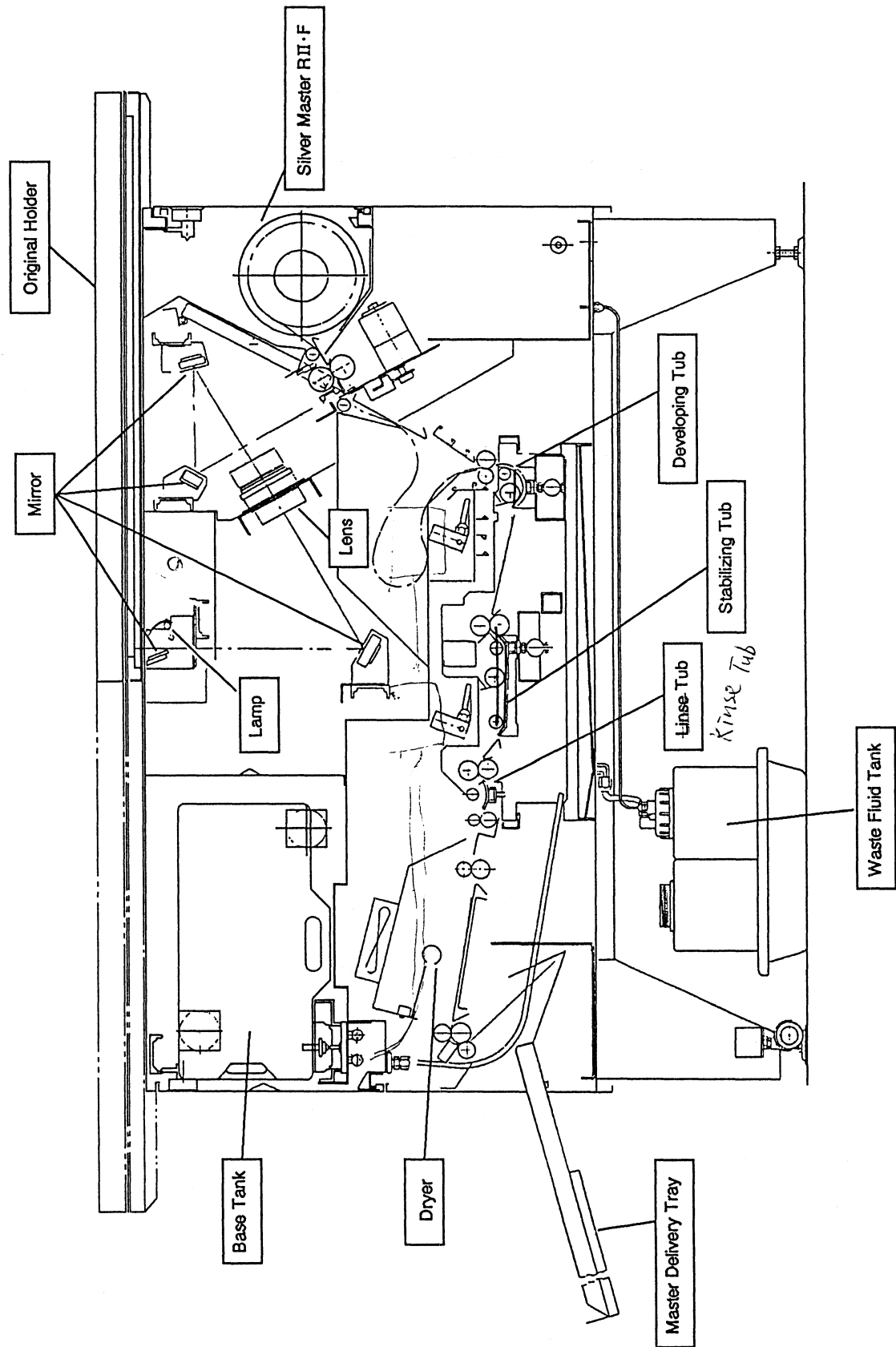

## 5. Precautions When Using

**Be careful with the original setting section!**

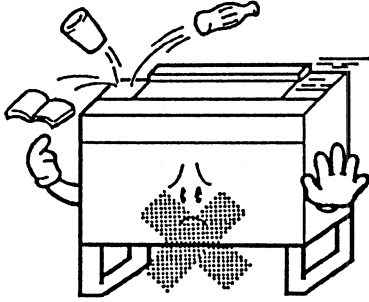

Do not place anything on the original setting section.  
If the START key is pressed, the original setting section moves to the left.

**Keep hands off!**

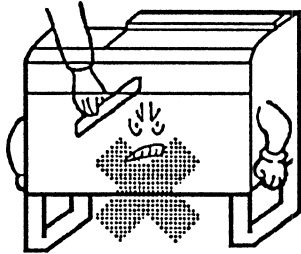

Do not directly touch the lens mirror with your hands.  
This may deteriorate both performance and quality.

## 6. Installation Conditions

### Vibration

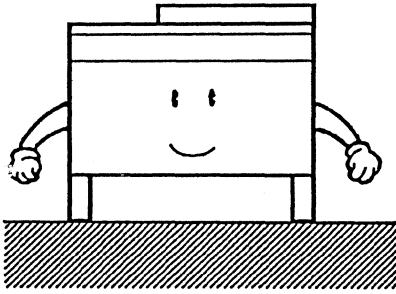

Select a horizontal surface that is free of vibration. The unit weights 245 kg/540 Lb (without processing solution).

### Normal Temperature/Humidity

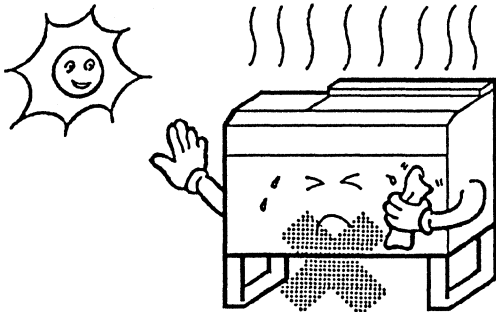

Select a location where the temperature is from 10°C to 30°C (50°F to 86°F), and the humidity is from 40% to 70%. Avoid a location that is exposed to direct sunlight.

Power Supply: Single-Phase 200 ~ 240 V,  
3.8 kW

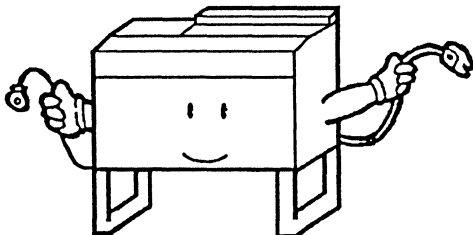

- Use dedicated wiring for the power supply. Keep the voltage fluctuation to within  $\pm 10\%$ .
- Connect to a power supply with an earth leakage breaker. Have the power supply connection carried out by a qualified electrician.
- To prevent electric shock, make sure that the grounding wire of maximum resistance 100 Ohms is connected.

### Service Area

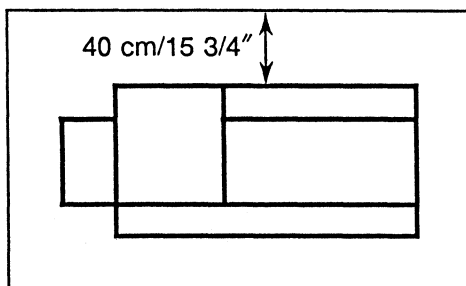

Secure a service area for maintenance and inspections.

### Machine Dimensions:

197.5 (W) × 92 (D) × 110 (H) cm

77 3/4" × 36 7/32" × 43 5/16" inch

# 7. Names and Functions of Parts

## 7-1 Configuration

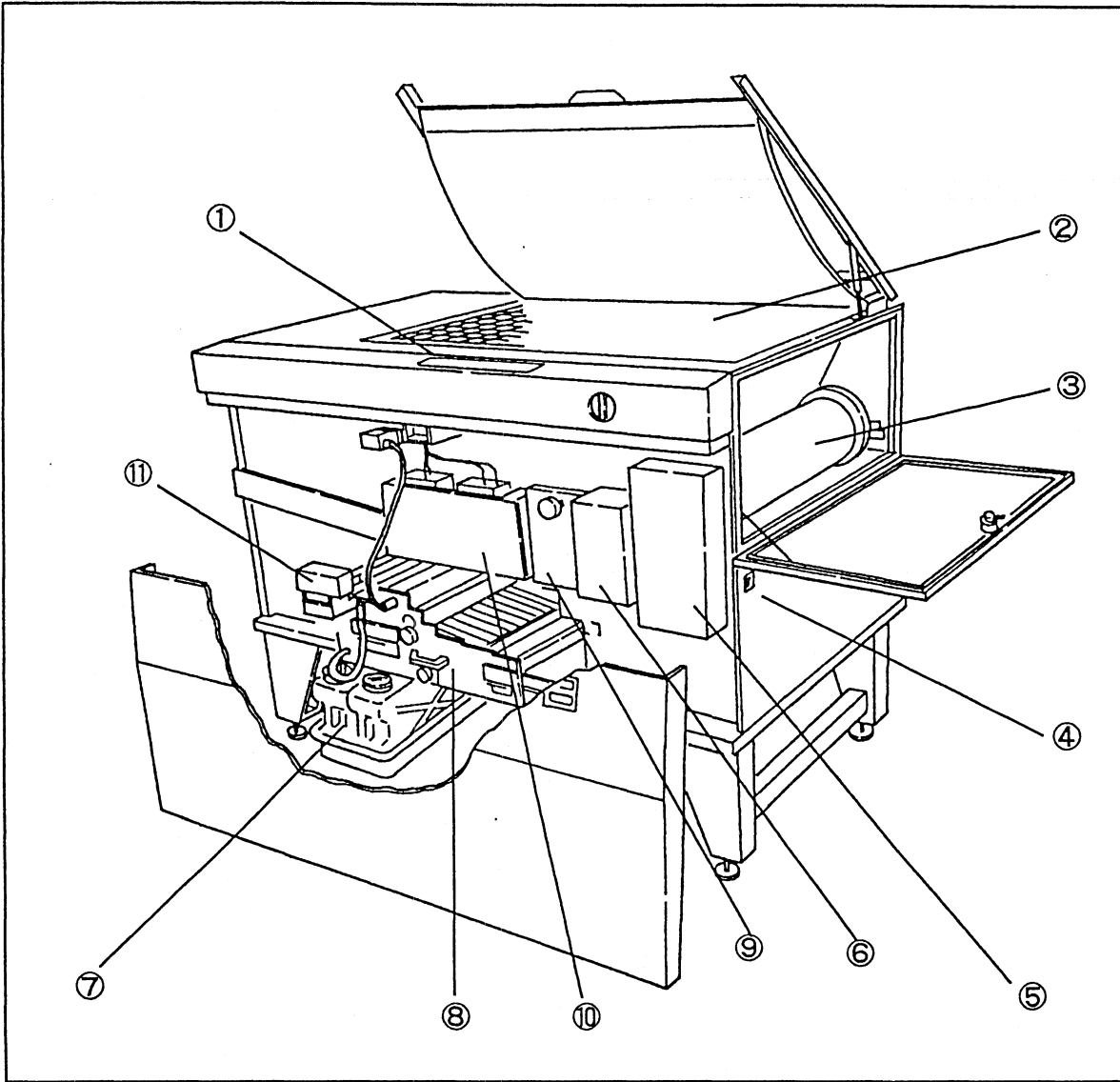

① Control panel

② Original setting section.

This is where the original is set.

③ Master magazine section

This is where the master is set.

④ Power switch

⑤ Control board section (CPU)

⑥ Cutter section

⑦ Waste fluid tank section

⑧ Processor section

Exposed Silver Master is developed and fixed.

⑨ Plate access cover

⑩ Cistern tank

⑪ Rinse replenisher tank section

## 7-2 Names of Parts

### 7-2-1 Power Switch

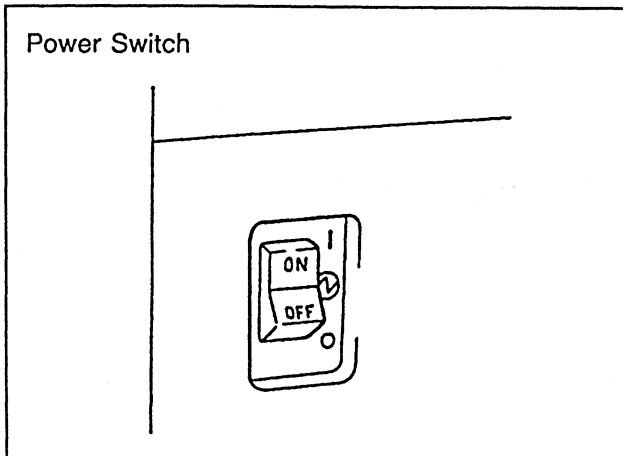

If this switch is turned ON, power is supplied to the control circuits, processor motors, dryer and panel heater, and items are displayed for five seconds each to check the conditions of each section.

- \* Nothing is displayed for one second after power is turned ON.
- \* If an abnormal sound is heard during a photographing operation, immediately turn the power switch OFF.

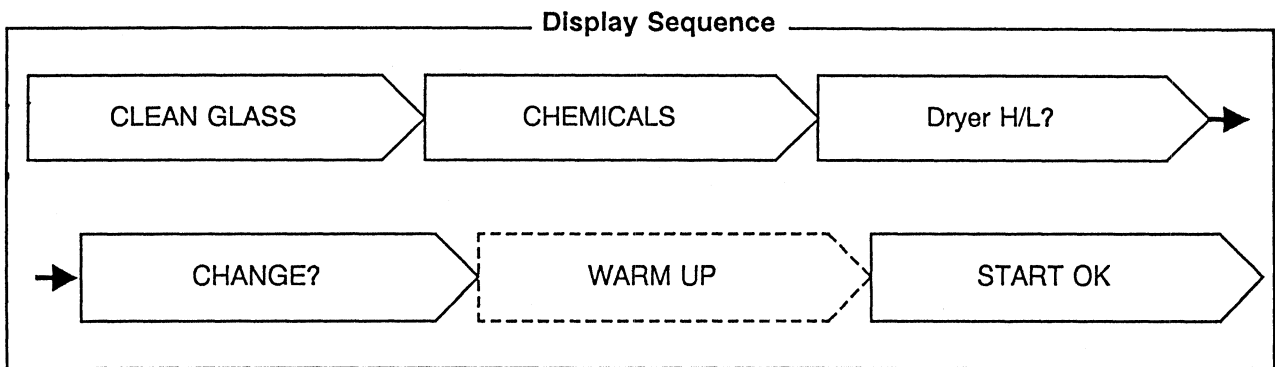

Press the "START key" to stop the display. Press the **C** key to restart.

Note that the  START key is used to carry out the "CHANGE ?" operation. If the chemical is not to be replaced, press the **C** key. See page 25 for details about handling chemicals.

→ See "Replenishment Procedure" (Page 23)

[Note]

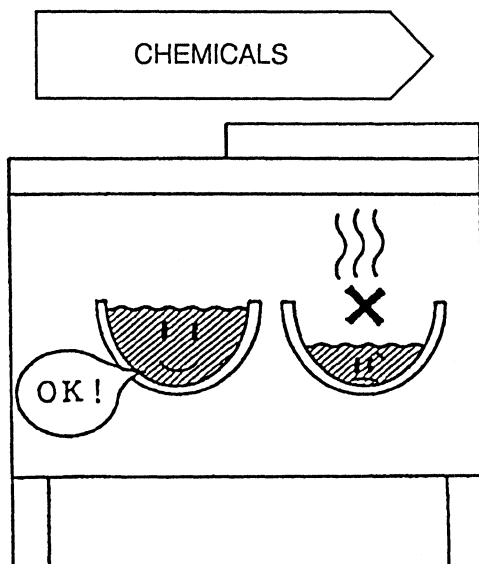

**Always check the processing solution before operation.**

When the machine has stopped for a long time, the solution level becomes low due to evaporation.

- \* When checking the processing solution, check the solution level of the processing bath, and when low, manually replenish the solution until it overflows.

→ See "Replenishment Procedure" (Page 23)

## 7-2-2 Control Panel

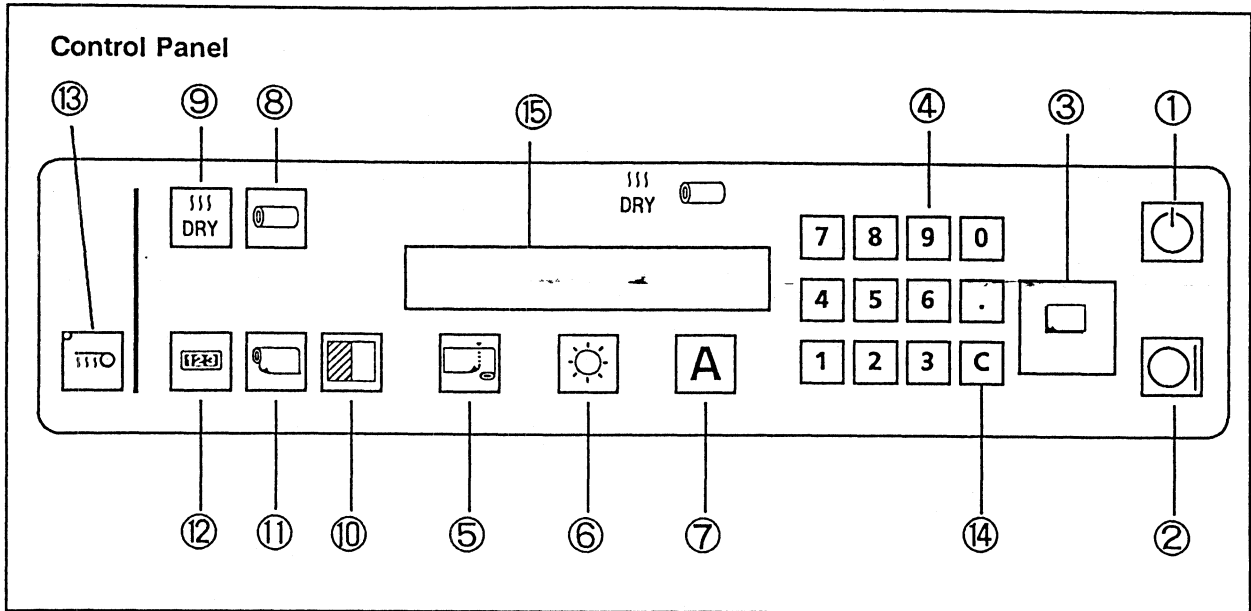

### ① Stand By Key

Press this key to save power when the machine is stopped for a long time, or to clear the power save status.

“Stand By” is displayed, and the original setting section moves to the specified position.

#### \* Automatic Power Save Function \*

If nothing was keyed in for 10 minutes, an intermittent buzzer rings, and the machine automatically enters power save status. If the power save key is pressed again, the original setting section returns to the original position.

If the power save status continues for three hours, the power turn OFF automatically.

**[Note]** Do not place hands or an object on the paper discharge side top cover.

### ② Power Key

When operation ends, set the nip roller release handle to free (  $\text{O}$  ), and press this key. The original setting section moves to the specified position, and a message to notify a start operation check is displayed.

Items are each displayed for 5 seconds, to check the status at operation end.

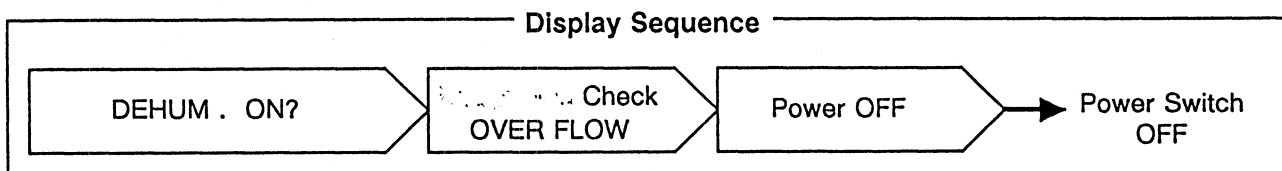

**[Note]** Do not turn the power switch OFF when the dehumidifier switch is ON.



③  Start Key

If this key is pressed when “Start OK” is displayed, reproduction starts.

This key also has the following functions:

- i) If pressed when “SET UP” or “CHECK” is displayed, the display status is maintained, and “Checking” is displayed.

Press the  key to clear, and advance to the next check.

④ Tenkey pad  to 

Used for the numerical input of various data.

⑤  Feed Length Data Input Key

- i) If this key is pressed, after inputting numerical data (mm units or inch units) by the tenkey pad, the master feed length is set and displayed.

**[Note]** If data, other than the input range (370 to 820 mm/14.56” to 32.28”) is input, “SET UP ERR” is displayed.

Reset with the  key and input again.

- ii) Input key for photographing data in division mode.

⑥  Exposure Data Input Key, Original Lighting Key

- i) If this key is pressed after inputting numerical data (0 to 99) by the tenkey pad, exposure data is set and displayed.

(The standard exposure is about 40 to 60, although this depends on the density of the original.)

The exposure increases as the numerical value becomes bigger.

\* Complete unexposed photographing can be carried out if the light intensity is set to “0”.

- ii) If this key is pressed when “Start OK” is displayed, the light source is lit for 30 seconds, illuminating the original.

Press the  key to stop this operation.

⑦  Auto-memory Key

Nine channels of frequently used master feed length and exposure data can be stored.

i) Data Input

After inputting the master feed length and exposure data, press the  key while pressing the memory number (1 to 9), by the tenkey pad.

ii) Data Callup

If this key is pressed after inputting the memory number (0 to 9) data is called up.

iii) If the master width is not input before this key is pressed, the modes will change to Manual Replenishing, Manual Draining, and Cleaning.

⑧  Master Width Setting Key



i) If this key is pressed after inputting the master width by the tenkey pad, the master width is set and displayed.

\* Area is calculated by this data and master feed length data. The processing solution is automatically replenished.

ii) The type of master (RII, F) is input.

F is input by the  key.

(Example) 

6	1	0	.		→ 610F. . . .F175, F100 with 610 width is input
6	1	0			→ 610. . . . .RII with 610 width is input

⑨  Dryer Key

This key sets the dryer temperature to either “High” or “Low”. Set according to the drying state of the master.

i) H (High)

Set to “H” when the environment temperature is low, when the master does not dry well, and when the SLM-F175 Silver Master is used.

ii) L (Low)

Set to “L” when the SLM-RII, SLM-F100 Silver Master is used.

⑩  Exposure Mode Key

This key selects the Exposing mode: standard, Double exposure, Multiple exposure.



◇ Modes

There are nine modes:



1) Standard Mode

START OK	L	610F (24.01)
820mm (32.28")	55	

Press the key once.

2) Side Gripping Margin Mode



(See page 29)

ORG. L ?		594 (23.38)
820mm (32.28")		50





Press the key twice.

3) Auto Double Exposure Mode with Side Gripping Margin (See page 31)

GUTTER ?		10 (0.39)
820mm (32.28")		50





\* The number of times the  key is pressed is counted from the "Standard Mode" screen position.

\* It is possible to reset to the "Standard Mode" screen from any position using the  and the  keys.

4) Auto Multiple Exposure Mode with Side Gripping Margin (See page 35)



Three Times

TOTAL. L ?		550 (21.65)
820mm (32.28")		50



Four Times



5) Multiple Exposure Mode with Side Gripping Margin (See page 37)

TOTAL. L ?		700 (27.55)
820mm (32.28")		50



Five Times



6) Top Edge Gripping Margin Mode (See page 39)

GRIPPER ?		40 (1.57)
820mm (32.28")		50



Six Times



7) Auto Double Exposure Mode with Top Gripping Margin (See page 41)

GRIPPER ?		50 (1.96)
820mm (32.28")		50



Seven Times



8) Auto Multiple Exposure Mode with Top Gripping Margin (See page 45)

GRIPPER ?		35 (1.37)
820mm (32.28")		50



Press  key eight times.

9) Multiple Exposure Mode with Top Gripping Margin (See page 47)

GRIPPER ?		45 (1.77)
820mm (32.28")		50



⑪  Total Length Display Key

TOTAL LEN	L	610F (24F)
0075cm * *	50	

- The current master length in use is displayed while pressing this key.

[Example] 0075 cm

75 cm is used.

- Reset the master length to use.
  - Data is reset to "0" if the  and the  keys are pressed.
  - Data is automatically reset when the master reaches the end.



⑫  Count Display Key

EXP. COUNT	L	610F (24F)
2395	50	

- The current count number is displayed while pressing this key.

[Example] 2395

2395 plates have been processed.

- Reset Count Number.
  - Data is reset to "0" if the  and the  keys are pressed.

⑬  Dehumidifier Switch

Press this switch for ON/OFF operation of the defogger for dehumidification.

This dehumidifies the inside of the machine, and prevents condensation caused by sudden temperature changes.

When operating at night, set the  power key to OFF, without turning the power switch OFF.

The lamp on the panel is lit when this switch is ON.

⑭  Clear Key

This key is used to cancel and in the following instances.

- i) To clear numerical input, and numerical input setting mistakes.
- ii) To stop the buzzer when a master splice is detected at the end of the master.
- iii) To quit after starting operation, due to a data change, for example. The light source goes out when the master feed length is 370 mm (14 1/2") or more. The original setting section returns to the original position after quitting.
- iv) To fast forward the start operation check and end operation check items.  
*[Note] If the "Heating" display is cleared, a normal plate cannot be created, because the processing solution does not reach the correct temperature.  
 Set the power key to OFF once, then ON again.*
- v) To cancel data called up by an auto-memory channel, and to return to original data.
- vi) To stop all maintenance mode operations.
- vii) To stop original lighting.
- viii) To stop, manual replenishment, and manual draining.

DRY 

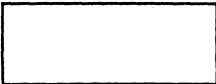
⑮  Display

Displays the operational status of the machine, and error messages.

1. Condition Messages

- |                                        |                                             |
|----------------------------------------|---------------------------------------------|
| A. Start OK .....                      | Reproduction is possible                    |
| B. Exposing .....                      | Photographing in progress                   |
| C. Stand By .....                      | Power saving function in operation          |
| .....                                  | → See section on power saving key, (page 9) |
| E. Wait .....                          | Master splice being detected                |
| Joint (together with buzzer sound) ... |                                             |
| .....                                  |                                             |
| G. Wait .....                          | Processing solution being replaced          |
| Change                                 | (Automatic replenishment)                   |

H. Wait . . . . .	Recovering from previous error in progress Recoverly
I. Door (together with buzzer sound) . . . . .	Close front door, or upper right, or upper left cover of main unit.
J. Nip Free . . . . .	Set nip roller release handle to free ( $\text{\textcircled{O}}$ ).
K. Over Flow . . . . . (together with buzzer sound)	Waste fluid tank full → See section on waste fluid tank, (page 21).
L. Empty . . . . . DEV. (together with buzzer sound)	Replenish developer in tank.
M. Empty . . . . . ST. (together with buzzer sound)	Replenish fixer in tank.
N. Tub Level . . . . . Dev. Check	Replenish developer in development processing tank of processor.
O. Tub Level . . . . . ST. Check	Replenish fixer in fixing processing tank of processor.
P. Processor Check (together with buzzer sound) . . . . .	Connector of processor not connected to main unit
Q. Nip Check . . . . .	Set nip roller release handle to lock ( $\text{\textcircled{O}}$ ).
R. 1) Empty (together with buzzer sound) . . . . .	No master (photosensitive material)
2) Master Remove (together with buzzer sound) . . . . .	Remove master strip in main unit by hand. → See section on master end, (page 19).
S. Light . . . . .	Original lighting being carried out
T. Warm Up . . . . .	Developer has not yet reached set temperature.
U. Setup Err . . . . .	Data, other than setting range, was input

**2. Condition Check (at start operation and end operation) display**

**3. Exposure Data Display**

**4. Master Feed Data Display**

**5. Dryer H/L Display**

**6. Double Exposure, Multiple Exposure Display**

**7. Other Data Display**

**8. Maintenance Display (when maintenance functions are being executed)**

**9. Error Display**

→ See section on errors, (page 59).

## 7-3 Original Setting Section

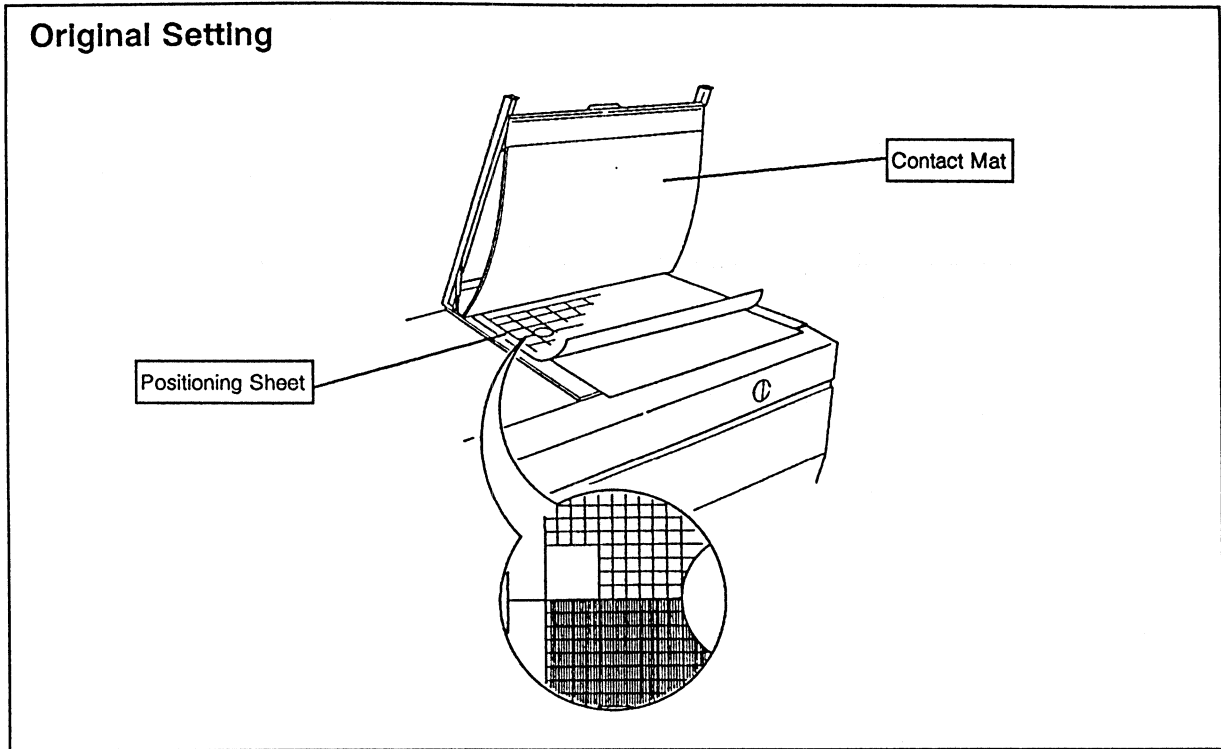

**[Note]** Since the original setting section moves horizontally, do not place anything on top of the main unit. Do not touch the section when it is moving.

### 7-3-1 Setting Original

- ① Hold the handle and gently raise the original frame. A spring stops the frame at the specified position. (Do not let go of the original until it stops.)
- ② Place the original on a glass, with the original surface down, then bring the positioning sheet down and set the original in place. Close the original frame gently.

**[Note]** Raising or lowering the original contact mat quickly may cause a disorder.

### 7-3-2 Positioning of Original

- ① A 0 reference line is indicated on the original positioning sheet. This indicates the leading edge position of the master.  
Since the double exposure area by the slit exposure system comes to the leading edge, 6 mm (0.24") or so cannot be exposed.
- ② From 0 to 300 mm (in feed direction) of the original positioning sheet is ruled with 1 mm size squares. Use this to set the original.
- ③ A pin bar is included as a standard accessory. Affix the pin bar at the desired position with double-sided tape.

## 7-4 Lens/Mirror Section

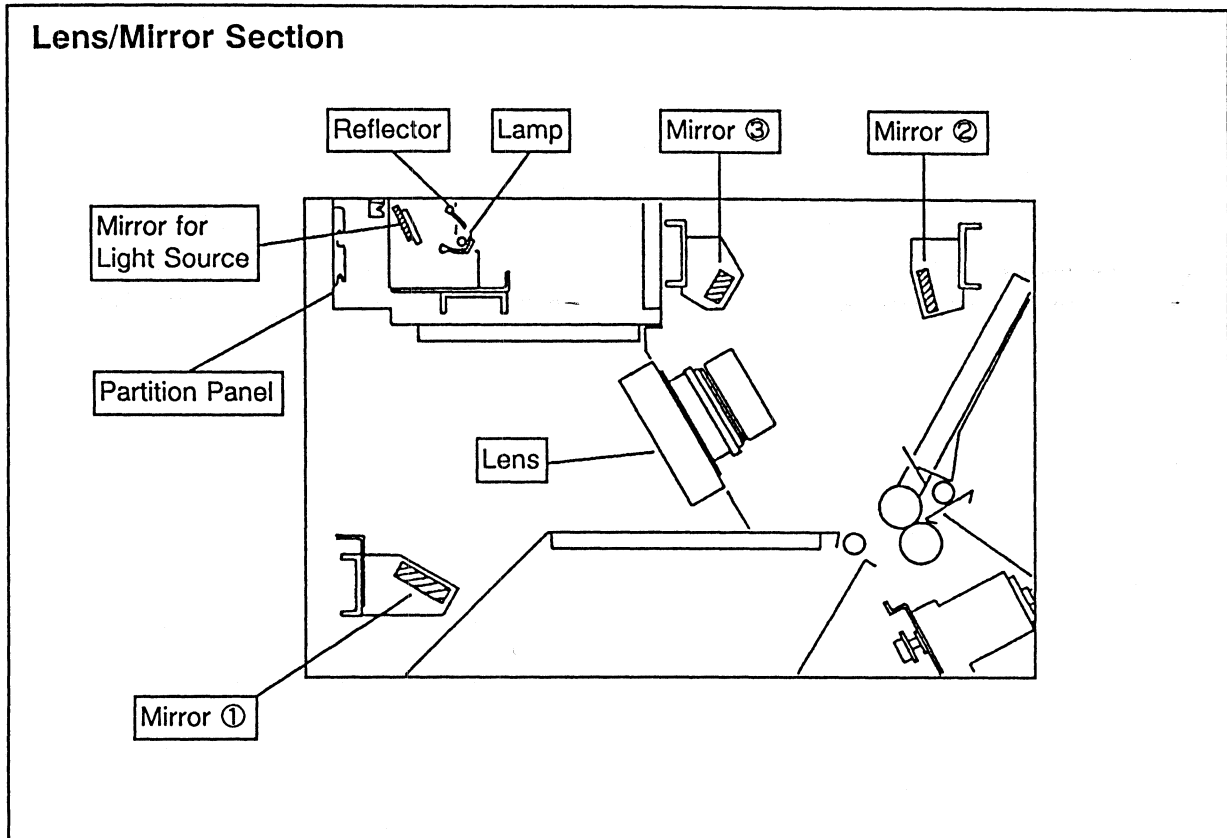

- When the lamp is lit, the light of the lamp and the light reflected by the reflector, and the mirror for the light source, are irradiated onto the original surface.
- Light from the original (image) is reflected by mirror ①, transmitted to the lens, and irradiated onto the master via mirrors ② and ③.
- The lens and mirrors are fixed. When the original setting section moves to the left, the master is fed in sync, and an image is photographed onto the master.

**[Note]** • *Since many mirrors are used, install the unit in a dust-free, dry location.*

- *Do not touch the mirrors or lens when replacing lamps or when cleaning inside the unit.*

## 7-5 Master Magazine Section

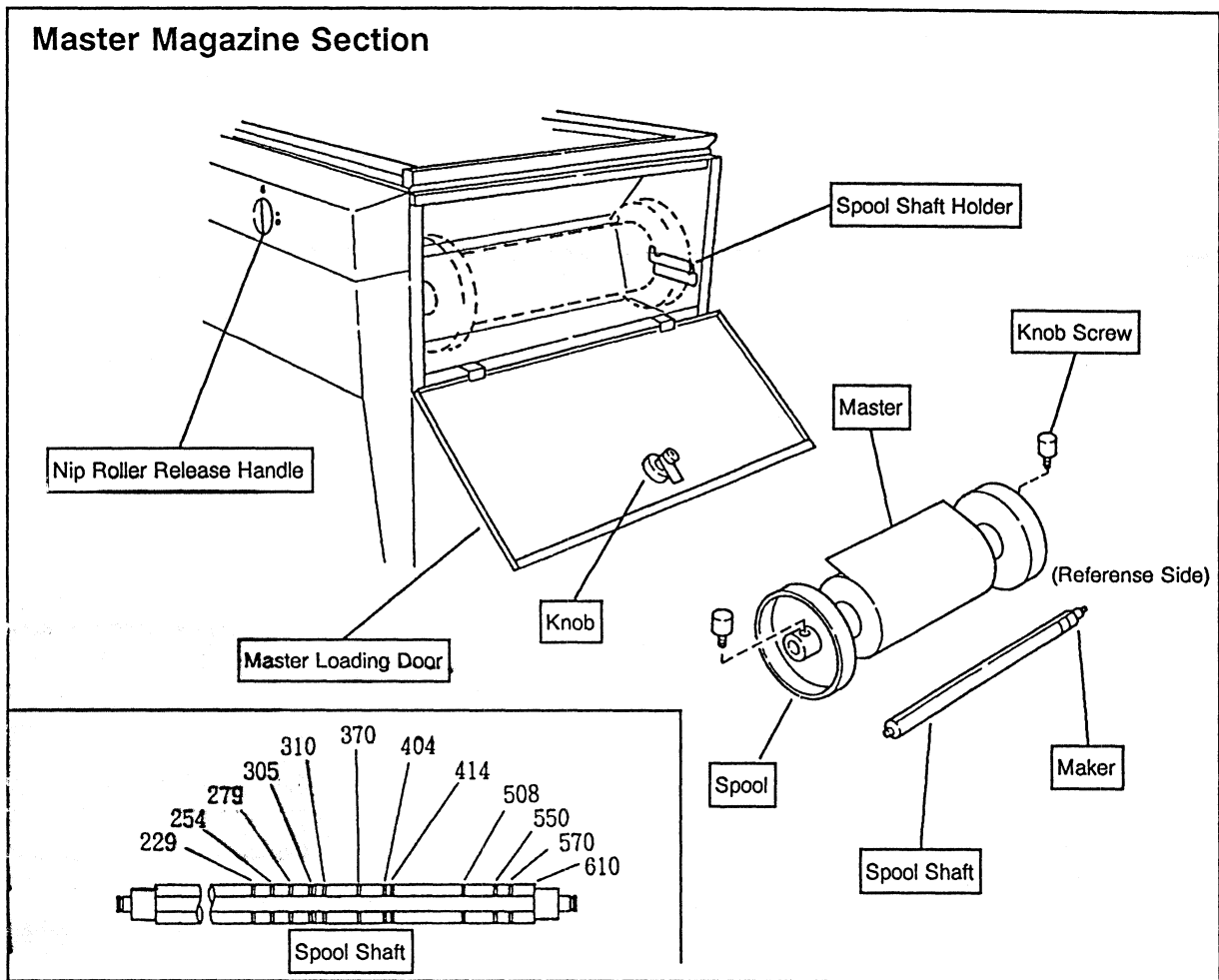

### 7-5-1 How to Set the Master

#### 1) SLM-R11 Silver Master

- ① Set to power save status by pressing the power save key .
- ② Turn the knob of the master loading door, and open the door by pulling toward you.
- ③ According to the width of the master to be used, match the base side (right side) end of the spool and the marked line of the shaft, (and secure with a screw to a flat surface).
- ④ Pass the master through the spool shaft, and insert the internal roll of the master paper into the spool. Insert the master so that the master is rolled clockwise as viewed from the spool base side.
- ⑤ Insert the other side of the spool to the shaft, and secure with a screw.
- ⑥ Correctly set the spool to the spool shaft holder, while checking the right and left of the spool.
- ⑦ Completely remove the adhesive tape stuck to the master.  
**[Note]** Make sure that no glue is remaining.
- ⑧ The buzzer sounds if the master is inserted between the feed roller and nip roller. Insert the master for about 60 mm or more from that position, stop inserting when you feel the end of the master has made contact.

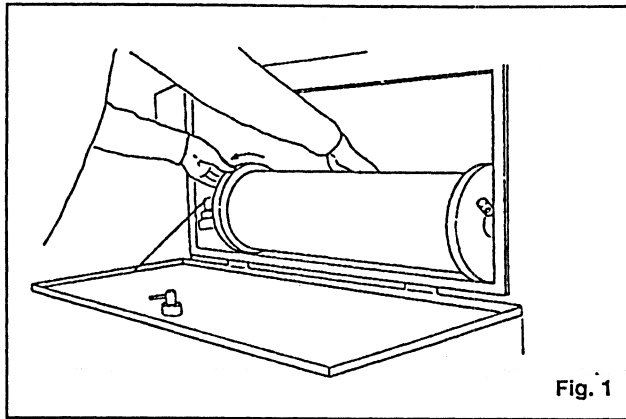



Fig. 1

- ⑨ Rewind the spool 5 to 10 mm (1/4" to 1/2") while lightly pressing the center of the master with your finger. (See Fig. 1)
- ⑩ Set the nip roller release handle to lock (  ).
- ⑪ Stretch the master, and check that it is straight, and not slack.
- ⑫ Close the master loading section cover.
- ⑬ Input the master width on the control panel.

## 2) SLM-F Silver Master

- ① The SLM-F has spools or black paper on both sides. Set the SLM-F in place without removing the spools.

*[Note] If the spools are removed or opened, external light (room light) will fog the edge of the SLM-F.*

- ② Set the SLM-F according to procedure 7-5-1 SLM-RII above.
- ③ The SLM-F has about 2 m (78 3/4") of lead paper. Feed in the same way as when photographing normally. When "Wait Joint" is displayed at the 3rd plate of a 820 mm (32 1/4") feed, normal exposing can be carried out from the next plate.

## 7-5-2 Master End

If the master runs out while feeding, ① "Empty" or ② "Master. Remove" is displayed (together with buzzer sound).

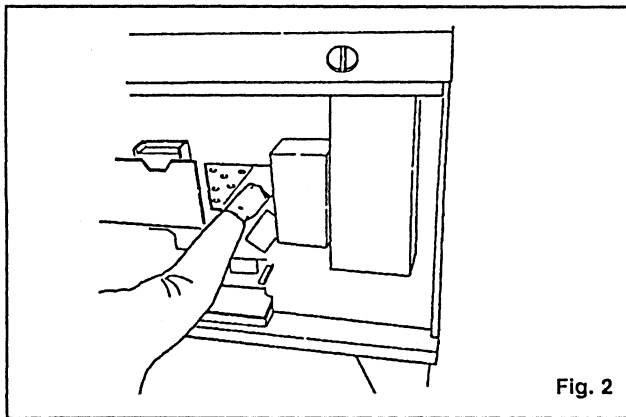

Fig. 2

In the case of ①, the master is automatically discharged. For ②, open the front door of the main unit, remove the plate access cover, and remove the master from the main unit.

## 7-5-3 Master Splice Detection

If a master splice is detected "Wait Joint" is displayed with a buzzer sound. Processing is carried out automatically. When "Start OK" is displayed, expose again. (When a splice is detected, a 370 (min.) to 1070 mm (max.) plate is fed.)



## 7-6 Base Solution Tank Section

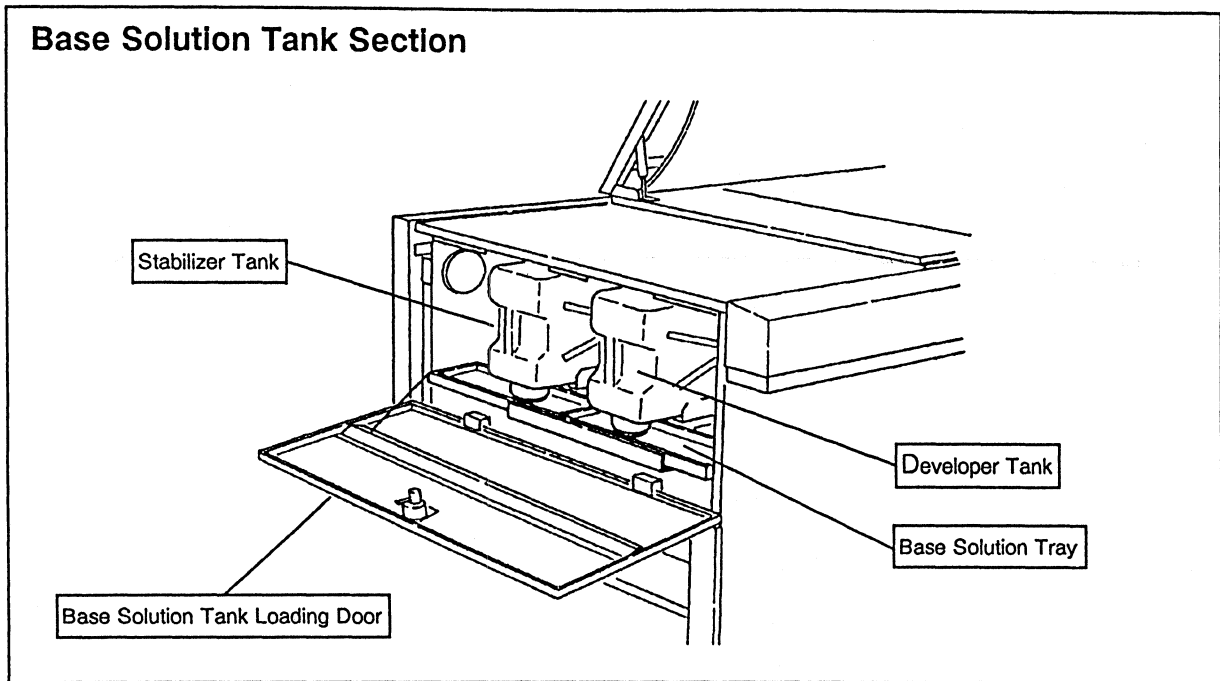

### 7-6-1 Preparation of Processing Solution

- Open the base solution tank loading door, and remove the developer tank and stabilizer tank.
- Use the dedicated measuring cup to prepare the processing solution
- In the winter time or when the water temperature is seasonally low, use warm water that is from 30°C to 35°C (86°F to 95°F).

### 7-6-2 Developer Tank [Capacity: 10 liters (2.63 US gal. )]

#### Preparing Developer (SLM-AC)

Prepare the developer to a mixing ratio of 1: 1

- ① Add 5 liters of water to 5 liters of undiluted SLM-AC Silver Master developer. Mix well, then pour into the developer tank.
- ② Correctly set the tank in place, containing the developer, into the main unit with the cap facing down.

### 7-6-3 Fixer Tank [Capacity: 10 liters (2.63 US gal. )]

#### Preparing Fixer (SLM-ST)

Prepare the developer to a mixing ratio of 1: 3

- ① Add 7.5 liters of water to 2.5 liters of undiluted SLM-ST Silver Master stabilizer. Mix well, then pour into the stabilizer tank.
- ② Correctly set the tank in place, containing the stabilizer, into the main unit with the cap facing down.

#### 7-6-4 Control of Processing Solution

- ① The message below is displayed (together with a buzzer sound) when the processing solution in the base solution tank runs out.

Empty DEV.	or	Empty ST.
---------------	----	--------------

\* Operation cannot start.

\* Turn the buzzer OFF with the **C** key.

- ② Replenish the processing solution in the tank.

**[Note]** *Do not set the base tank in the tray when there is solution in the base solution tray. Drain off the solution of the cistern tank from the drain valve until there is no solution in the base solution tray, then set the base solution tank.*

## 7-7 Waste fluid Tank Section

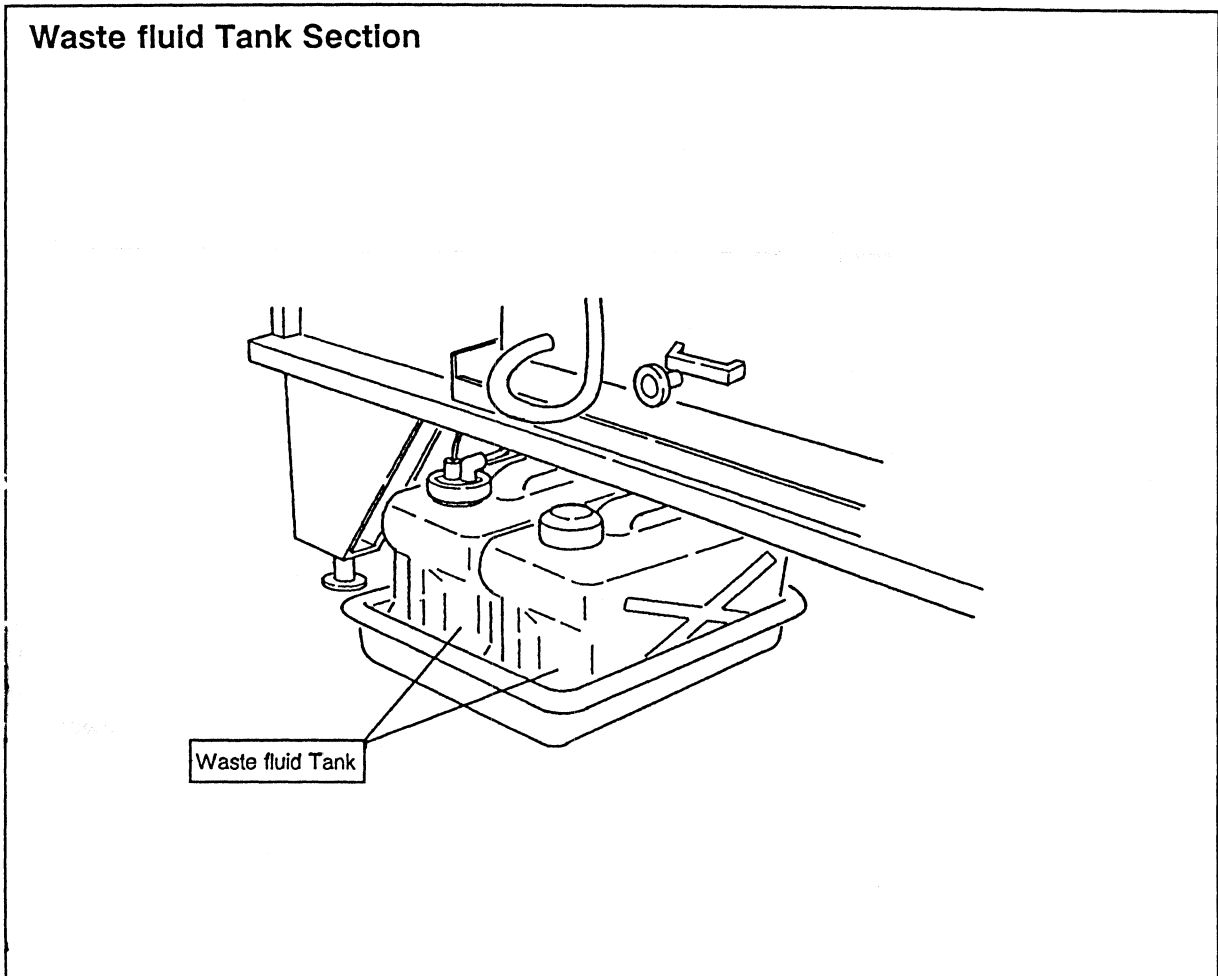

- ① The message below is displayed (together with a buzzer sound) and draining stops when the waste fluid tank becomes full.

Over  
Flow

- \* Operation cannot start.
  - \* Turn the buzzer OFF with the **C** key.
- ② Remove the cap, pull out the full tank, and replace with a spare tank.
  - ③ Drain the rest of the waste fluid by pressing the **C** key.

### **[Precautions When Handling Processing Chemicals]**

- ① **Never** drink processing chemicals or allow them to come in contact with the eyes.  
(Should an emergency arise, see a doctor immediately.)
- ② If processing solution comes into contact with skin or clothing, immediately wash off with running water.
- ③ Follow instructions and use processing chemicals correctly.
- ④ Store chemicals in a safe location, away from the reach of children.



- ② Press the **A** key twice to change the mode to the manual drain mode.

Both developer and stabilizer are drained.

MANUAL	000
DRAIN	

- The  START key executes these functions.  
(When a solution is replenished, replenishment automatically stops when the solution reaches a fixed level.)
- The **C** key stops operation.
- “Finish” is displayed when replenishment or draining ends.

MANUAL	FINISH
REPLENISH	

5 Cleaning

- Press the **A** key three times to change the mode to the cleaning mode. The replenishment and drain channels of the processing solution are washed.

- 1) The message “Cleaning” is displayed.

CLEANING	000
----------	-----

- 2) Press the  START key.

CLEANING	000
REMOVE	MAIN TANK

\* Pull out the base solution tank.

- 3) After the base solution tank is pulled out, press the **C** key to advance to the next operation.

CLEANING	000
DRAIN	CISTERN

\* Open the valve lever to drain the developer and stabilizer solutions in the cistern tank.

Prepare a bucket and drain the waste fluid.

After draining, make sure that the lever valve is closed.

		<p>4) After draining all of the solutions into the cistern tank, press the <span style="border: 1px solid black; padding: 2px;">C</span> key to advance to the next operation.</p> <div style="border: 1px solid black; padding: 5px; margin: 10px 0;"> CLEANING <span style="float: right;">000</span>  REPL. WATER </div> <p>* Pour about 1 liter (0.26 US gal. ) of water into the base solution tray.</p> <p>5) Press the <span style="border: 1px solid black; padding: 2px;">C</span> key, and the replenishment and <u>d</u>rain channels of processing solutions are cleaned.</p> <div style="border: 1px solid black; padding: 5px; margin: 10px 0;"> CLEANING <span style="float: right;">123</span>  WAIT </div> <p>* This takes about 10 minutes.</p> <p>6) When cleaning of replenishment and drain channels is finished, the message below is displayed.</p> <div style="border: 1px solid black; padding: 5px; margin: 10px 0;"> CLEANING <span style="float: right;">456</span>  DRAIN <span style="margin-left: 100px;">CISTERN</span> </div> <p>* Open the valve lever again to drain the solutions (both developer and stabilizer) in the cistern tank. After draining, make sure that the valve lever is closed.</p> <p>7) If the <span style="border: 1px solid black; padding: 2px;">C</span> key is pressed, "Cleaning Finish" is displayed.</p> <div style="border: 1px solid black; padding: 5px; margin: 10px 0;"> CLEANING <span style="margin-left: 100px;">FINISH</span> </div> <p>When cleaning is carried out, drain about 100 cc of developer and fixer when the next operation is started.</p>	
6	Maintenance Replenishment/ Drain	This function is used by service personnel to measure the flow rate. It is also used to clean the processor section. This is carried out in maintenance mode.	It is executed by <span style="border: 1px solid black; padding: 2px;">F23</span> + tenkey pad input. (See page 49).

**[Note]** 1. Perform cleaning when the unit is not used for a long period of time (1 week or more).

- \* Emptying a solution without cleaning the replenishment and drain channels causes disorders.
- \* Drain about 100 cc of developer and fixer when the next operation is started (because water used for cleaning mixes in).

## 8-2 Control of Rinse Tub

So that less paper is wasted at the beginning of printing, this unit is provided with a washing process after the fixing bath process.

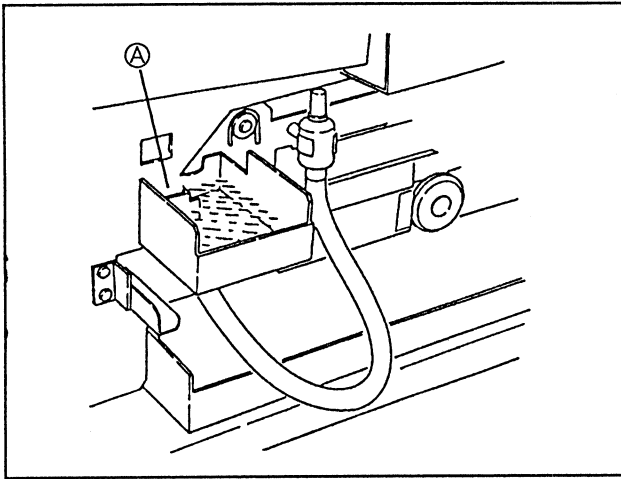





- ① Use tap water as rinsing liquid. Pour until the "A" level is reached (about 500 cc).
- ② The replenisher tank is a 1liter tank. Never forget to pour water in and set.
- ③ Change the rinse tub and replenisher tank every day. Also, since the water go stale, change the water in the replenisher tank at the same time.
- ④ When replacing water, prepare a bucket for waste fluid, drain the water with a drain hose, then pour water back into the rinse bath again. (Return the drain hose back to its original position).

**[Note]** Do not forget to pour water into the rinse Tub, otherwise problems may occur with the unit.

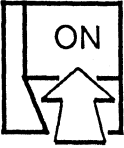
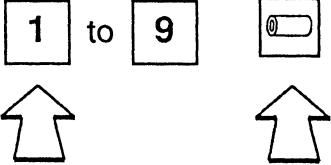
# 9. Exposing

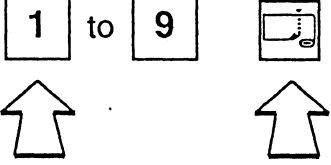
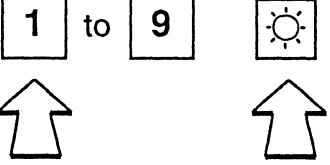
## 9-1 Exposing Procedure

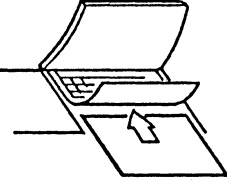
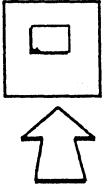
<p>1) Turning on the Power Switch - Start Operation Check Turn on the power switch to start operation.</p>	
<p>2) Roll width selection Input the master width with the tenkey pad, and set by pressing the master select key.</p>	
<p>3) Dryer HIGH/LOW selection According to the dryness of the master, set the dryer to either "High" or "Low" with the dryer key.</p>	
<p>4) Master Feed Length selection Input the master feed length with the tenkey pad, and set by pressing the feed length data input key.</p>	
<p>5) Exposure light level input According to the original, input the exposure with the tenkey pad, and set by pressing the exposure data input key.</p>	
<p>6) Standard, Double, Multiple Exposure selection Press the exposure mode key, and set either standard, Double or Multiple exposure.</p>	
<p>7) Positioning the Original Set the original in place on the copy glass with the original surface facing down, then set to the desired position using the marker of the positioning sheet.</p>	
<p>8) Start Key ON If the START key is pressed when "Start OK" is displayed, the photographing operation advances automatically.</p>	



## 9-2 How To Determine the Standard Exposure

Since silver-halide emulsion is coated on the Silver Master, sensitivity may differ slightly, depending on the manufactured lot.

Check the sensitivity before exposure. If a master with a different lot No. is used.

Under-exposure causes either scumming or an image to spread.

Over-exposure causes either a plate jump or image choking.

By correctly adjusting the exposure, the high quality features of the Silver Master RII and Silver Master F can be used most effectively.

Also refer to the "Silver Master Technical Guide".

- ① A test chart and standard exposure sample are provided with the CP-610 S.  
According to the exposing procedure above, reproduce the test chart, compare it with the exposure sample, and then determine the standard exposure.
- ② Adjust the exposure judging the gray scale of the reproduced test chart, and set the standard exposure. Standard exposure: exposure when the 12th step of the gray scale test chart becomes the 1st step of silver extraction, as in the enclosed reproduction sample.

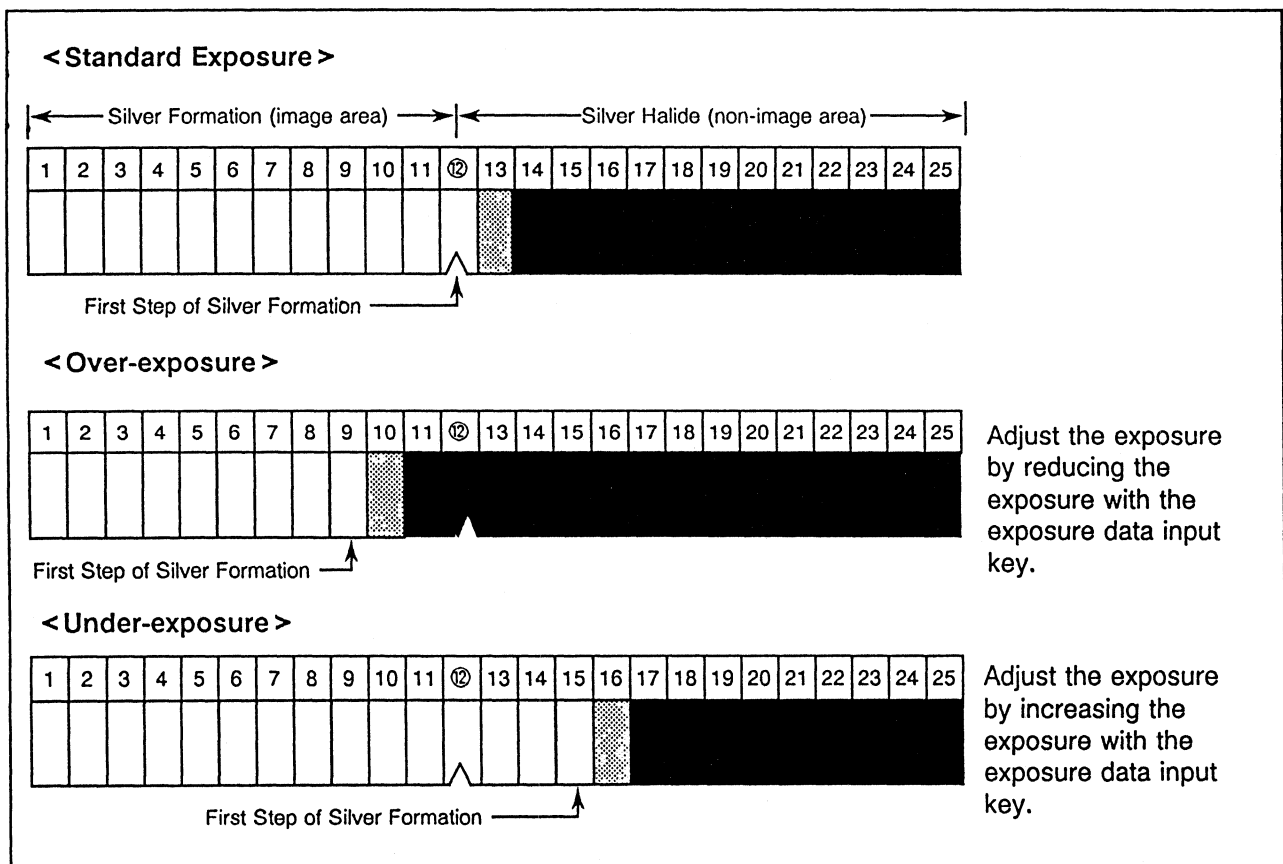

**[Note]** The standard exposure sample may become discolored after a long period of time.  
Store in a drawer or dark place.

### 9-3 How to Determine the Optimum Exposure Level

- ① The optimum exposure level differs, depending on the type of original actually used.
- ② The optimum exposure level of each original varies according to the printing conditions (printing press, paper, ink, etc.). The table below lists basic data. Determine the correct exposure after assembling data that reflects local printing conditions.

[Reference] Correct Exposure for Various Originals

Increase or decrease from the standard exposure

Original		Increase/Decrease from optimum exposure level
Original State	Original Type	
Characters and image of original have low density or are blurred.	Pencil Writing	0 to - 20% Decrease the exposure to the extent that a non-image area does not become whitish.
	Duplication	
Characters are spread and are illegible, or the base of the original is dark.	Photo-type setting, computer photo-type setting	- 10 to + 20%
	Type	0 to + 30% (increase exposure)
	Halftone original	+ 20 to + 30% (increase exposure)

# 10. Photographing Method

## ◆ Side Gripping margin mode ◆

\*\* Making an exposure in the center along the master (plate) feed length.\*\*

— How to Set the Original —

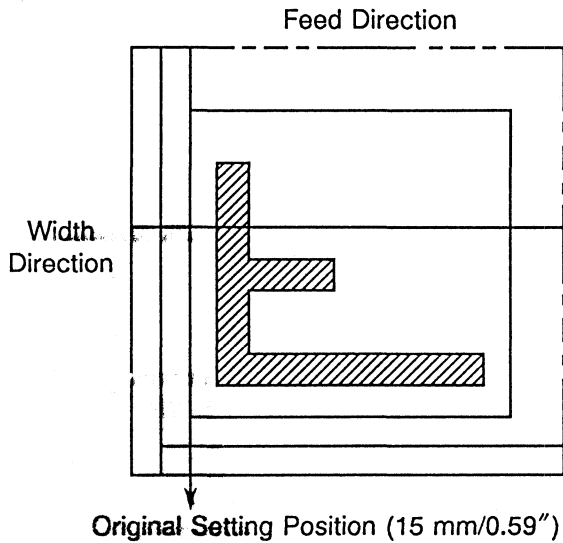

### <Feed Direction >

- Set the original at the displayed set position. Align the original with the marker of the positioning sheet.

### <Width Direction >

- Shift the original toward you by the amount of the desired gripper margin.

— How to Exposure —

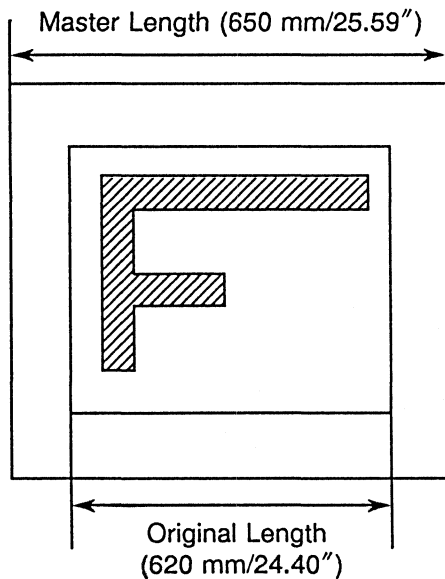

– Method of Operation –

- 1) Input <Master Feed Length> and <Roll Width> to the standard exposure mode screen.

START OK	L	550 (21.65)
650mm (25.59")	50	

- 2) Select the side gripping margin mode with the  key.

ORG. L ?		
650mm (25.59")		50

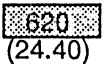

- 3) Input <Original Length> by key operation with the tenkey pad,    and .

ORG. L ?	SIDE	
650mm (25.59")	GS	50  (24.40)

\* While the  key is pressed, the input data is displayed at the upper right of the screen.

- 4) The Original Setting Position  (0.59) calculated from the master feed length and original length, is displayed.

START OK	SIDE	 (0.59)
650mm (25.59")	GS	50

- 5) Set the original aligned to line  (0.59) of the positioning sheet. Press the  START key to ON to start exposing.

The original length can also be changed in the "START OK" screen.

## ◆ Double exposure mode with side gripping margin ◆

\*\* By merely pressing the START key once, images are continuously exposed on two plates on both sides of the center line of the master feed length.\*\*

### ◇ Gutter Bleed 2-division Photographing

— How to Set Original —

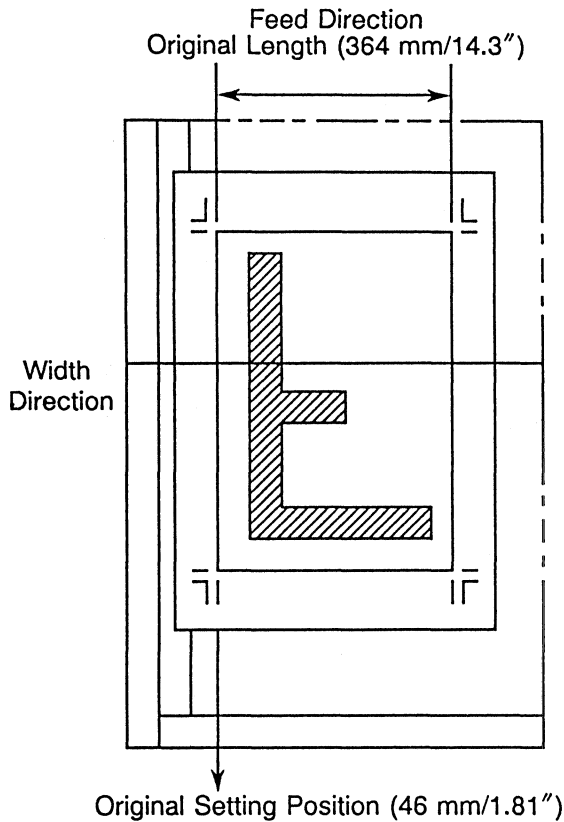

#### <Feed Direction >

- Set the cutting mark of the original at the displayed set position.  
Align the original with the marker of the positioning sheet.

#### <Width Direction >

- Shift the original toward you by the amount of the desired gripper margin.

— The way exposures are made on a plate —

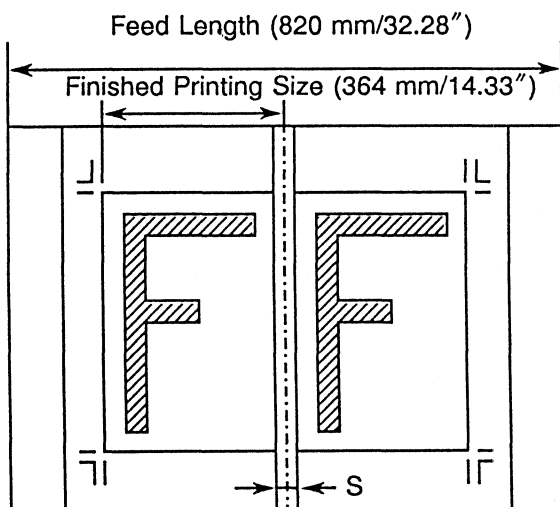

\* S: slit width



If the image is in the full length of the original, the image area at only the slit width (6 mm/0.24") will not be printed.

The minimum original length is 50 mm.

— Method of Operation —

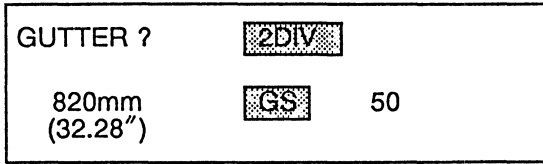



- 1) Select side gripping auto-double exposure mode with the  key.

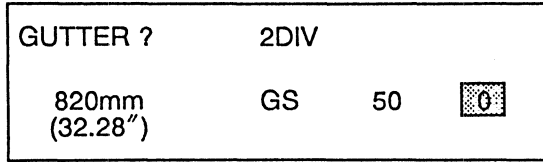



- 2) Input <Gutter Length?> by key operation with the tenkey pad  and .
- \* For the gutter bleed, normally input "0" for the gutter.



- \* While the  key is pressed, the input data is displayed at the upper right of the screen.

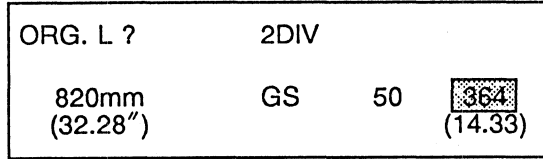

- 3) Input <Original Length> by key operation with the tenkey pad,    and .

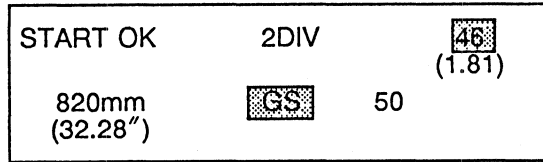

- \* While the  key is pressed, the input data is displayed at the upper right of the screen.

- 4) Original Setting Position  (1.81) is displayed.



- 5) Set the original aligned to line  (1.81) of the positioning sheet. Press the  START key to ON to start exposing.

The original length can also be changed in the START OK screen.

# ◇ Trimming Bleed Double Exposure

## — How to Set Original —

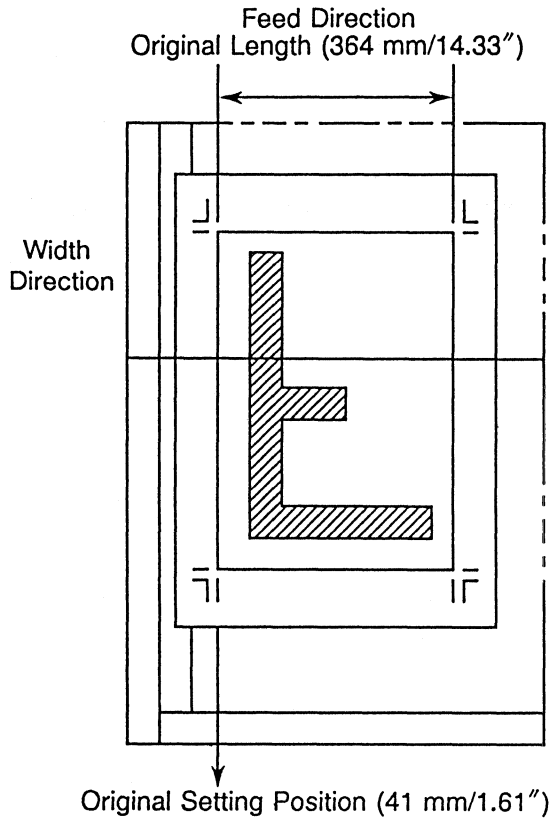

### <Feed Direction >

- Set the cutting mark of the original at the displayed set position.  
Align the original to the marker of the positioning sheet.

### <Width Direction >

- Shift the original toward you by the amount of the desired gripper margin.

## — How to Exposure —

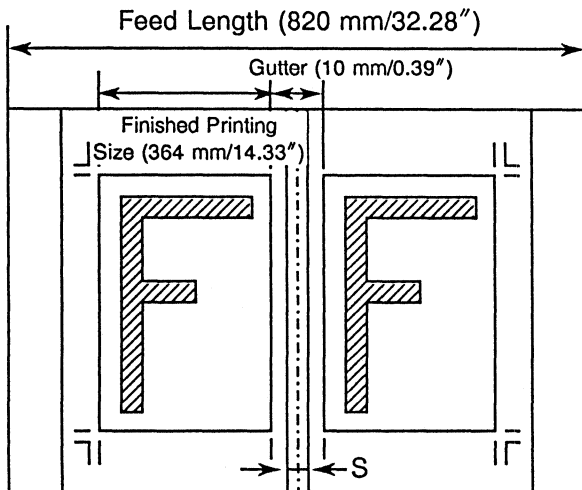





\* S: slit width

The minimum original length is 50 mm (1.96").

— Method of Operation —





- 1) Select side gripping double exposure mode with the  key.

GUTTER ?			
820mm (32.28")		50	

- 2) Input <Gutter Length?> by key operation with the tenkey pad   and .  
\* For trimming bleed, normally input 6 mm (0.23") or more for the gutter.

GUTTER ?	2DIV		
820mm (32.28")	GS	50	 (0.39)

- \* While the  key is pressed, the input data is displayed at the upper right of the screen.



- 3) Input <Original Length> by key operation with the tenkey pad,    and .

ORG. L ?	2DIV		
820mm (32.28")	GS	50	 (14.33)

- \* While the  key is pressed, the input data is displayed at the upper right of the screen.

- 4) Original Setting Position  (1.61) is displayed.

START OK	2DIV		 (1.61)
820mm (32.28")	GS	50	

- 5) Set the original aligned to line  (1.61) of the positioning sheet. Press the  START key to ON to start exposing.

The original length can also be changed in the START OK screen.



## ◆ Side Gripping Margin Auto-Multiple Exposure ◆

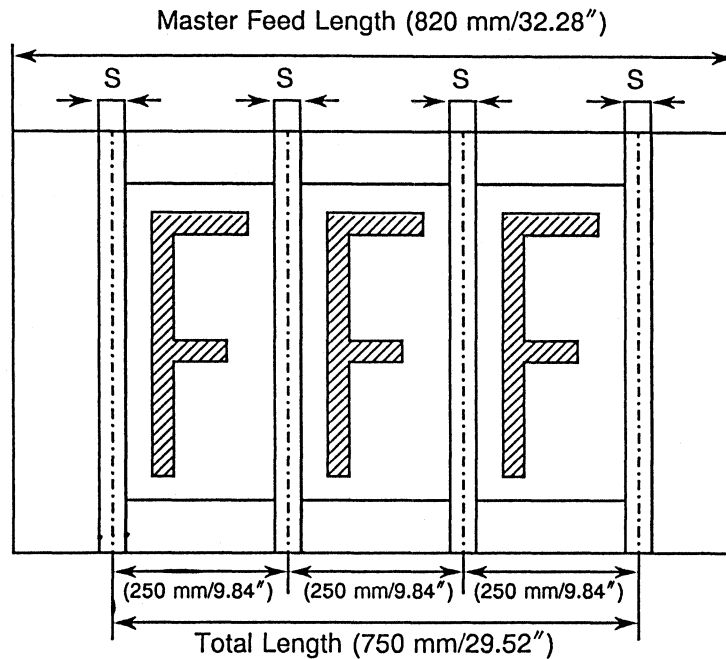

\*\* The same images are automatically exposed at the center of the master feed length each time that the START key is pressed.\*\*



The minimum original length is 50 mm (1.96").

### – Method of Operation –

- 1) Select the Side Gripping Margin Multiple Exposure mode with the  key.

TOTAL. L ?	 DIV. A
820mm (32.28")	 GS 50

- 2) Input <Original Length> by key operation with the tenkey pad, **7** **5** **0** and .

TOTAL. L ?	DIV. A
820mm (32.28")	GS 50  750 (29.52)

\* While the  key is pressed, the input data is displayed at the upper right of the screen.

- 3) Input <Original Length> by key operation with the tenkey pad, **2** **5** **0** and .

ORG. L ?	DIV. A
820mm (32.28")	GS 50  250 (9.84)

\* While the  key is pressed, the input data is displayed at the upper right of the screen.

- 4) Original Setting Position  (1.37) is displayed.

START OK	DIV. A	<input type="checkbox"/>
820mm (32.28")	GS	50

- 5) Set the original aligned to line  (1.37) of the positioning sheet. Press the  START key to ON to start exposing.

\* If the total length cannot be divided by the original length, an error occurs, and "SETUP ERR" is displayed.

The original length can also be changed in the START OK screen.

## ◆ Side Gripping Margin Multiple Exposure ◆

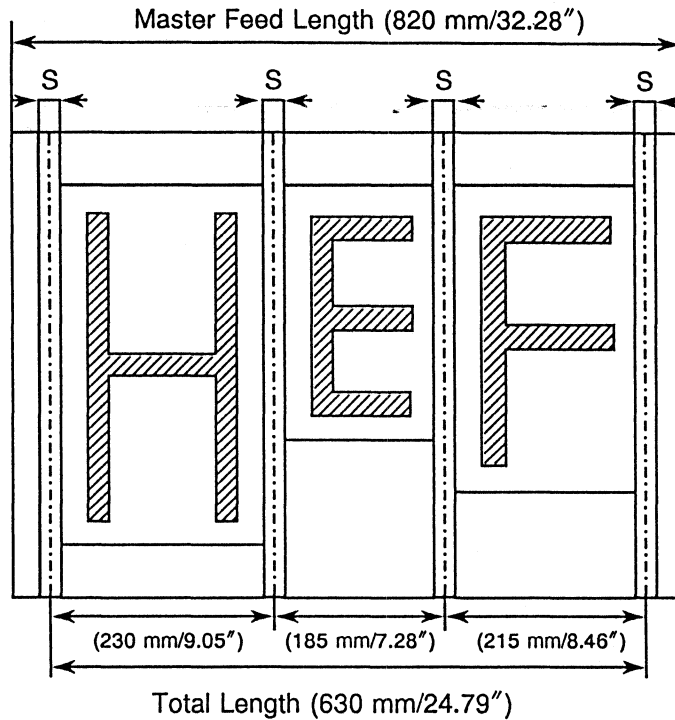

\*\* By pressing the START key every time, the same image will be automatically exposed at the center of the master feed length.\*\*





The minimum original length is 50 mm (1.96").

### — Method of Operation —

- 1) Select the side Gripping Margin Multiple Exposure by the  key.

TOTAL . L ?	 DIV. M
820mm (32.28")	 GS 50

- 2) Input <Total Length?> by key operation with the tenkey pad **6** **3** **0** and .

TOTAL . L ?	DIV. M
820mm (32.28")	GS 50 

\* While the  key is pressed, the input data is displayed at the upper right of the screen.

- 3) Input <Original Length> of the H plate by key operation with the tenkey pad **2** **3** **0** and .

ORG. L ?	DIV. M
820mm (32.28")	GS 50 

\* While the  key is pressed, the input data is displayed at the upper right of the screen.





4) Original Setting Position **95** (3.74") is displayed.

START OK	DIV. M	<b>95</b> (3.74)
820mm (32.28")	GS 50	

5) Set the original aligned to line **95** (3.74") of the positioning sheet. Press the  START key to ON to start exposing the H plate.

EXPOSING	DIV. M	230 (9.05)
400mm (15.74")	GS 50	

**400** : Total length of the E and F plates  
(15.74") (remaining amount) is displayed.

6) Input <Original Length> of the E plate by key operation with the tenkey pad    and .

START OK	DIV. M	95 (3.74)
400mm (15.74")	GS 50	<b>185</b> (7.28)





\* While the  key is pressed, the input data is displayed at the upper right of the screen.

7) Set the original at the Original Setting Position **95** (3.74).

Press the  START key to ON to start exposing the E plate.

EXPOSING	DIV. M	185 (7.28)
<b>215</b> mm (8.46")	GS 50	

**215** : The exposing length of the F plate (remaining amount) is displayed.

8) Input <Original Length> of the F plate by key operation with the tenkey pad    and .

START OK	DIV. M	95 (3.74)
820mm (32.28")	GS 50	<b>215</b> (8.46)

\* While the  key is pressed, the input data is displayed at the upper right of the screen.

9) Set the original at Original Setting Position **95** (3.74). Press the  START key to ON to start exposing the F plate.

EXPOSING	DIV. M	215 (8.46)
0mm (0")	GS 50	

10) Press the  exposing mode key if the remaining amount is not to be exposed.

## ◆ Top Edge Gripping Margin mode ◆

\*\* The image is exposed at the leading edge reference of the master.\*\*

### — How to Set Original —

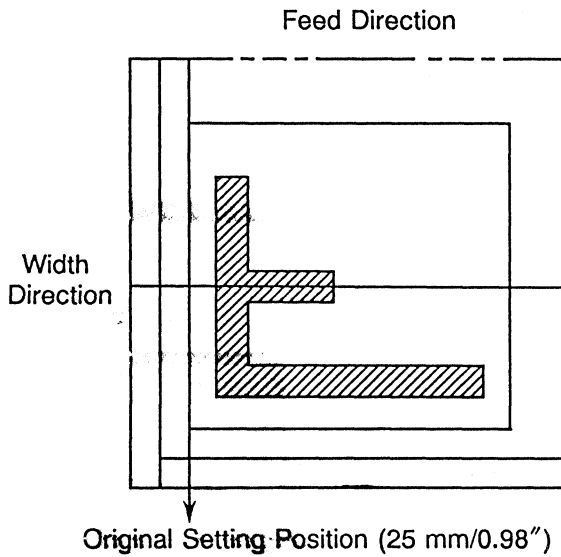

### <Feed Direction>

- Set the original at the displayed set position. Align the original with the marker of the positioning sheet.

### <Width Direction>

- Set the original at the center reference.

### — How to Exposure —

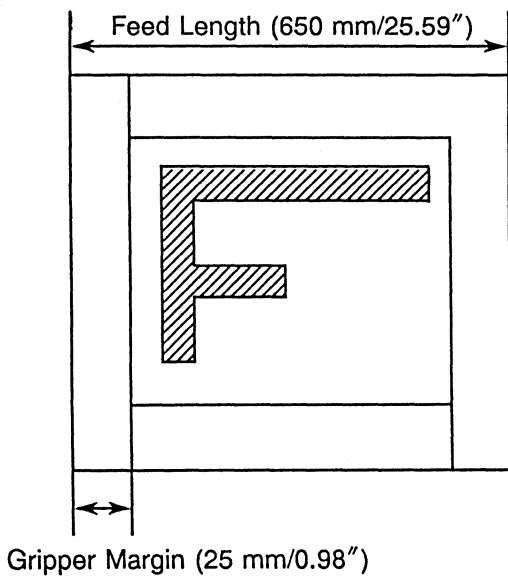



Input from 10 (0.39") to 99 mm (3.89") for the gripper margin.

— Method of Operation —

- 1) Input <Master Feed Length> and <Roll Width> to the standard exposing mode screen.

START OK	L	550 (21.65)
650mm (25.59")	50	

- 2) Select the Top Edge Gripping Margin mode with the  key.

GRIPPER ?		
650mm (25.59")		50



- 3) Input <Gripper Margin?> by key operation with the tenkey pad   and .

GRIPPER ?	TOP	
650mm (25.59")	GT	50  (0.98)

\* While the  key is pressed, the input data is displayed at the upper right of the screen.

- 4) Original Setting Position  (0.98) is displayed.

START OK	TOP	 (0.98)
650mm (25.59")	GT	50

- 5) Set the original aligned to line  (0.98) of the positioning sheet. Press the  START key to ON to start exposing.

## ◆ Top Edge Gripping Auto Double exposure ◆

\*\* By pressing the START key once, the image is exposed continuously in two plates at the leading edge reference of the master.\*\*

### ◇ Gutter Bleed Double Exposure

— How to Set Original —

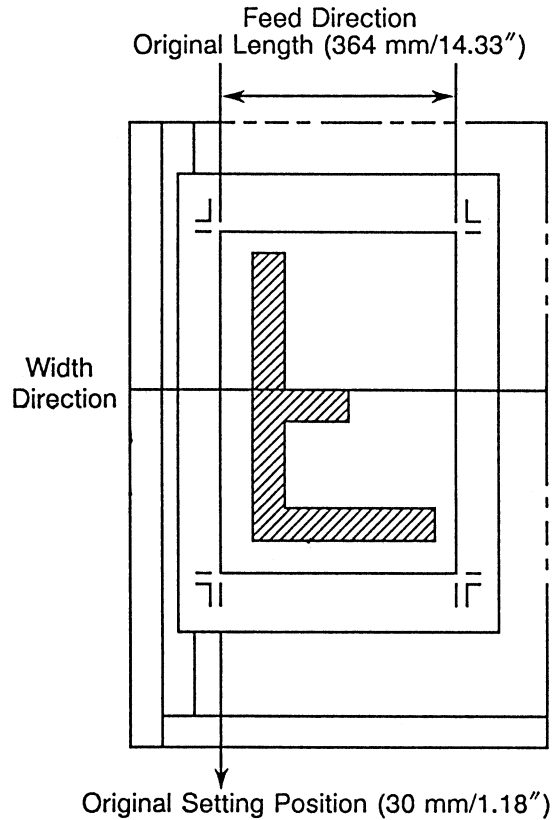

#### < Feed Direction >

- Set the original at the displayed set position.  
Align the original with the marker of the positioning sheet.

#### < Width Direction >

- Set the original at the center reference.

— How Exposure —

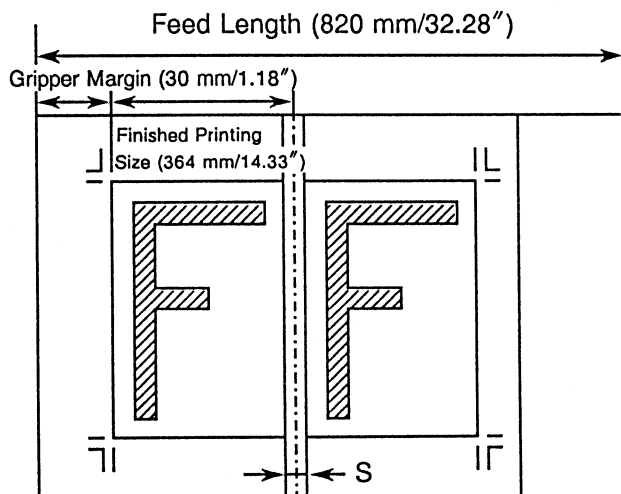





\* S: slit width

The minimum original length is 50 mm (1.96").

— Method of Operation —

- 1) Select Top Edge Gripping Margin Double Exposure mode with the  key.

GRIPPER ?		
820mm (32.28")		50

- 2) Input <Gripper Margin> by key operation with the tenkey pad   and .

GRIPPER ?	2DIV	
820mm (32.28")	GT	50  (1.18)





\* While the  key is pressed, the input data is displayed at the upper right of the screen.

- 3) Input <Gutter Length?> by key operation with the tenkey pad  and .

\* For gutter bleed, normally input "0" for the gutter.

GUTTER ?	2DIV	
820mm (32.28")	GT	50 

\* While the  key is pressed, the input data is displayed at the upper right of the screen.



- 4) Input <Original Length> by key operation with the tenkey pad    and .

ORIG. L ?	2DIV	
820mm (32.28")	GT	50  (14.33)

\* While the  key is pressed, the input data is displayed at the upper right of the screen.

- 5) Original Setting Position  (1.18) is displayed.

START OK	2DIV	 (1.18)
820mm (32.28")	GT	50

- 6) Set the original aligned to line  (1.18) of the positioning sheet. Press the  START key to ON to start exposing.

The original length can also be changed in the START OK screen.



# ◇ Trimming Bleed Top Edge Gripper Margin Double Exposure

## — How to Set Original —

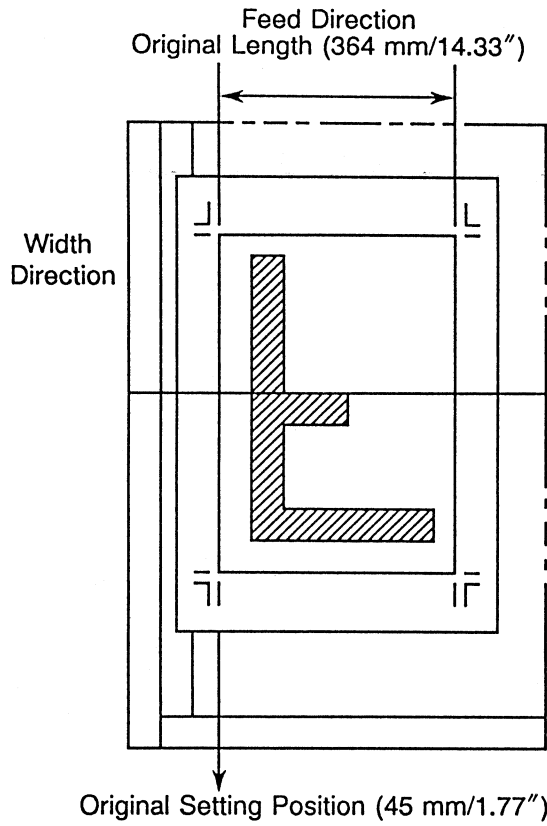

### <Feed Direction>

- Set the original at the displayed set position.

### <Width Direction>

- Set the original at the center reference.

## — How to Exposure —

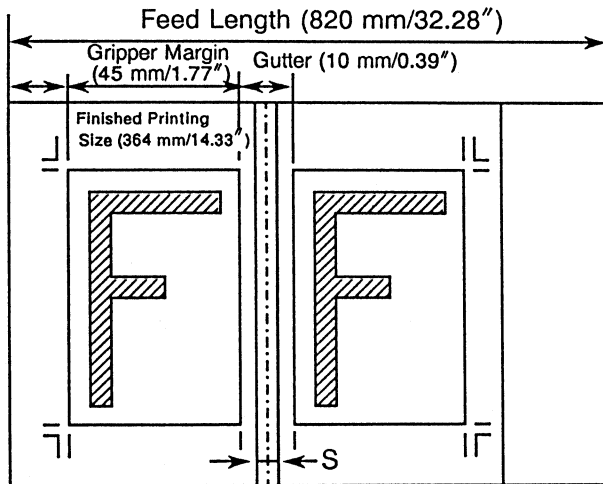





\* S: slit width

The minimum original length is 50 mm (1.96").

– Method of Operation –



- 1) Select Top Edge Gripping Double Exposure mode with the  key.

GRIPPER ?			
820mm (32.28")		50	

- 2) Input <Gripper Margin?> by key operation with the tenkey pad   and .

GRIPPER ?	2DIV		
820mm (32.28")	GT	50	 (1.77)





\* While the  key is pressed, the input data is displayed at the upper right of the screen.

- 3) Input <Gutter Length?> by key operation with the tenkey pad   and .

\* For trimming bleed, normally input 6 mm (0.23") or more for the gutter.

GUTTER ?	2DIV		
820mm (32.28")	GT	50	 (0.23)

\* While the  key is pressed, the input data is displayed at the upper right of the screen.



- 4) Input <Original Length> by key operation with the tenkey pad    and .

ORIG. L ?	2DIV		
820mm (32.28")	GT	50	 (14.33)

\* While the  key is pressed, the input data is displayed at the upper right of the screen.

- 5) Original Setting Position  (1.77) is displayed.

START OK	2DIV		 (1.77)
820mm (32.28")	GS	50	

- 6) Set the original aligned to line  (1.77) of the positioning sheet. Press the  START key to ON to start exposing.

The original length can also be changed in the START OK screen.

## ◆ Top Edge Gripping Margin Auto-Multiple Exposure ◆

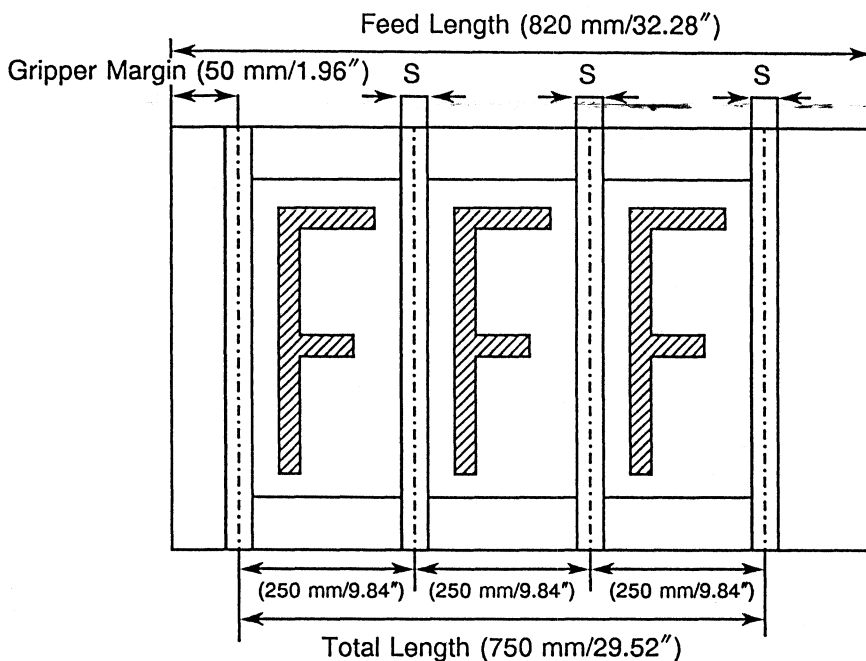

\*\* The same image will be automatically exposed at the leading edge reference of the master by merely pressing the START key.\*\*





The minimum original length is 50 mm (1.96").

### — Method of Operation —

- 1) Select Top Edge Gripping Margin Auto-Multiple Exposure mode with the  key.

GRIPPER ?		DIV A
820mm (32.28")		50

- 2) Input <Gripper Margin?> by key operation with the tenkey pad **5** **0** and .

GRIPPER ?	DIV A
820mm (32.28")	GT 50 

\* While the  key is pressed, the input data is displayed at the upper right of the screen.

- 3) Input <Total Length?> by key operation with the tenkey pad **7** **5** **0** and .

TOTAL. L ?	DIV A
820mm (32.28")	GT 50 

\* While the  key is pressed, the input data is displayed at the upper right of the screen.

4) Input <Original Length> by key operation with the tenkey pad **2** **5** **0** and .

ORIG. L ?	DIV A	
820mm (32.28")	GT 50	<b>250</b> (9.84)

\* While the  key is pressed, the input data is displayed at the upper right of the screen.

5) Original Setting Position **50** (1.98) is displayed.

START OK	* 2DIV *	<b>50</b> (1.98)
820mm (32.28")	GT 50	

6) Set the original aligned to line **50** (1.98) of the positioning sheet. Press the  START key to ON to start exposing.

The original length can also be changed in the START OK screen.

## ◆ Top Edge Gripper Multiple Exposure ◆

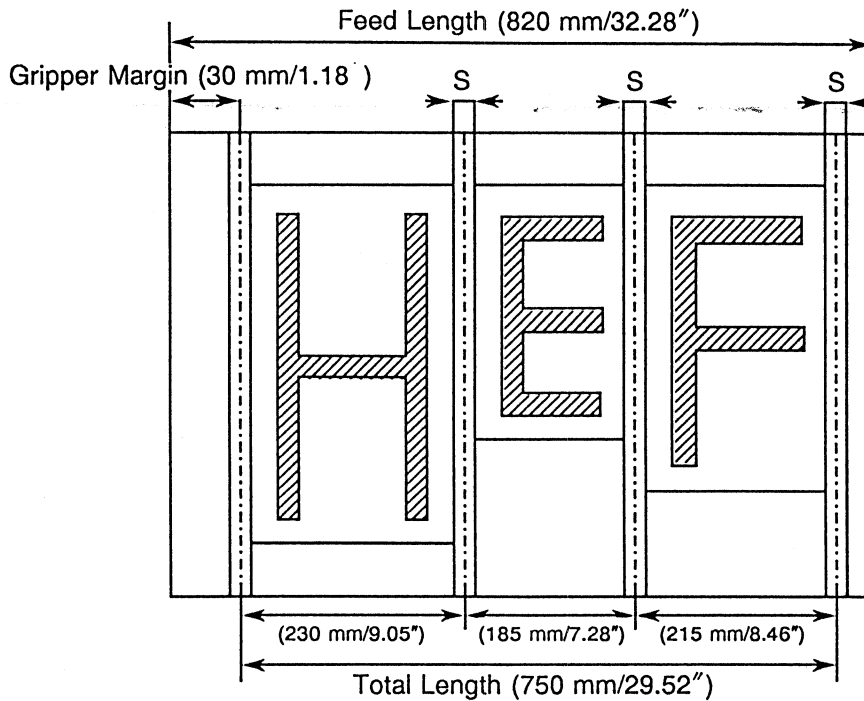

\*\* The image is photographed in multiple format at the leading edge reference of the master each time the  START key is pressed.\*\*



The minimum original length is 50 mm (1.96").

### — Method of Operation —

- 1) Select Top Edge Gripper Multiple Exposure mode with the  key.

GRIPPER ?	
820mm (32.28")	 50

- 2) Input <Gripper Margin?> by key operation with the tenkey pad **3 0** and .

GRIPPER ?	DIV M
820mm (32.28")	GT 50  (1.18)

\* While the  key is pressed, the input data is displayed at the upper right of the screen.

- 3) Input <Original Length> of the H plate by key operation with the tenkey pad **2 3 0** and .

GRIPPER ?	DIV M
820mm (32.28")	GT 50  (9.05)

\* While the  key is pressed, the input data is displayed at the upper right of the screen.





4) Original Setting Position **30**(1.18) is displayed.

START OK	DIV M	<b>30</b> (1.18)
820mm (32.28")	GT	50

5) Set the original aligned to line **30**(1.18) of the positioning sheet. Press the  START key to ON to start exposing the H plate.

EXPOSING	DIV M	230 (9.05)
<b>566</b> mm (21.88")	GT	50

**566** : The total length of E and F plates (remaining amount) is displayed.

6) Input <Original Length> of the E plate by key operation with the tenkey pad    and .





START OK	DIV M	30 (1.18)
560mm (21.88")	GT	50 <b>185</b> (7.28)

\* While the  key is pressed, the input data is displayed at the upper right of the screen.

7) Set the original at the Original Setting Position **30**(1.18).

Press the  START key to ON to start exposing the E plate.

EXPOSING	DIV M	185 (7.28)
<b>381</b> mm (15.0")	GT	50

8) Input <Original Length> of the F plate by key operation with the tenkey pad    and .

START OK	DIV M	30 (1.18)
381mm (15.0")	GT	50 <b>215</b> (8.46)

\* While the  key is pressed, the input data is displayed at the upper right of the screen.

9) Set the original at Original Setting Position **30**(1.18). Press the  START key to ON to start exposing the F plate.

EXPOSING	DIV M	215 (8.46)
<b>166</b> mm (6.53")	GT	50





















10) Press the  exposure mode key if the remaining amount is not to be exposed.





























# 11. Maintenance

## 11-1 Maintenance Mode

The maintenance mode key is used to check the operation of each section, and for general maintenance.

\* Enter maintenance mode in the "Stand By" status.

	Item	Key Operation	Purpose and Operation
1	Moving the Cutter Independently	 +  Press tenkey  while pressing the  count key.	* Cutter operation check. <ul style="list-style-type: none"> <li>When the cutter moves (in the cut direction) and reaches the inversion sensor, it returns to the original again. "MAINTENANCE CUTTER" is displayed.</li> </ul>
2	Moving the Original Setting Section Independently <i>[Note]</i> Set the nip roller release handle to free (0).	 +  Press tenkey  while pressing the   +  Press tenkey  while pressing the  count key.	* Replacing the Halogen Lamp * Cleaning the Copy glass <ul style="list-style-type: none"> <li>When the original setting section moves to the left, and reaches the end sensor, it stops. "MAINTENANCE ORIG. LEFT" is displayed.</li> <li>When the original setting section moves to the right, and reaches the original sensor, it stops. "MAINTENANCE ORIG. RIGHT" is displayed.</li> </ul>
3	Lighting Halogen Light Source Independently	 +  Press tenkey  while pressing the  count key.	* Halogen Light Source Lighting Check <ul style="list-style-type: none"> <li>The halogen lamp lights for 3 seconds, then automatically goes out. "Maintenance LIGHT" is displayed.</li> </ul>
4	Driving Processor Motor Independently	 +  Press tenkey  while pressing the  count key.	* Processor Motor Operation Check "MAINTENANCE PROCESSOR MOTOR" is displayed.

5	Replenishing Developer	 +  Press tenkey  while pressing the  count key.	<ul style="list-style-type: none"> <li>The developer is replenished.</li> </ul> Press the  key to stop this operation. "MAINTENANCE REPL. DEV." is displayed.
6	Replenishing Fixer	 +  Press tenkey  while pressing the  count key.	<ul style="list-style-type: none"> <li>The fixer is replenished.</li> </ul> Press the  key to stop this operation. "MAINTENANCE REPL. ST." is displayed.
7	Draining Developer	 +  Press tenkey  while pressing the  count key.	<ul style="list-style-type: none"> <li>* The developer is drained.</li> </ul> Press the  key to stop this operation. "MAINTENANCE DRAIN DEV." is displayed.
8	Draining Fixer	 +  Press tenkey  while pressing the  count key.	<ul style="list-style-type: none"> <li>* The fixer is drained.</li> </ul> Press the  key to stop this operation. "MAINTENANCE DRAIN ST." is displayed.
9	Moving Original Setting Section to Center Independently	 +  Press tenkey  while pressing the  count key.	<ul style="list-style-type: none"> <li>* When main unit is moving:</li> <li>The original setting section moves to the center.</li> </ul> "MAINTENANCE ORIG. CENTER" is displayed.
10	Turning on Back Light Independently (option)	 +  Press tenkey  while pressing the  count key.	<ul style="list-style-type: none"> <li>* Back Light Lighting Check</li> <li>The back light lights for three seconds, then automatically goes out.</li> </ul> "MAINTENANCE BACK LIGHT" is displayed.



## 11-2 General Care

### 11-2-1 Cleaning Processor Section

During reproduction, silver from the master plate dissolves, and paper, dust and chemicals stick to rollers. This will dirty the processor section. This area must be cleaned regularly.

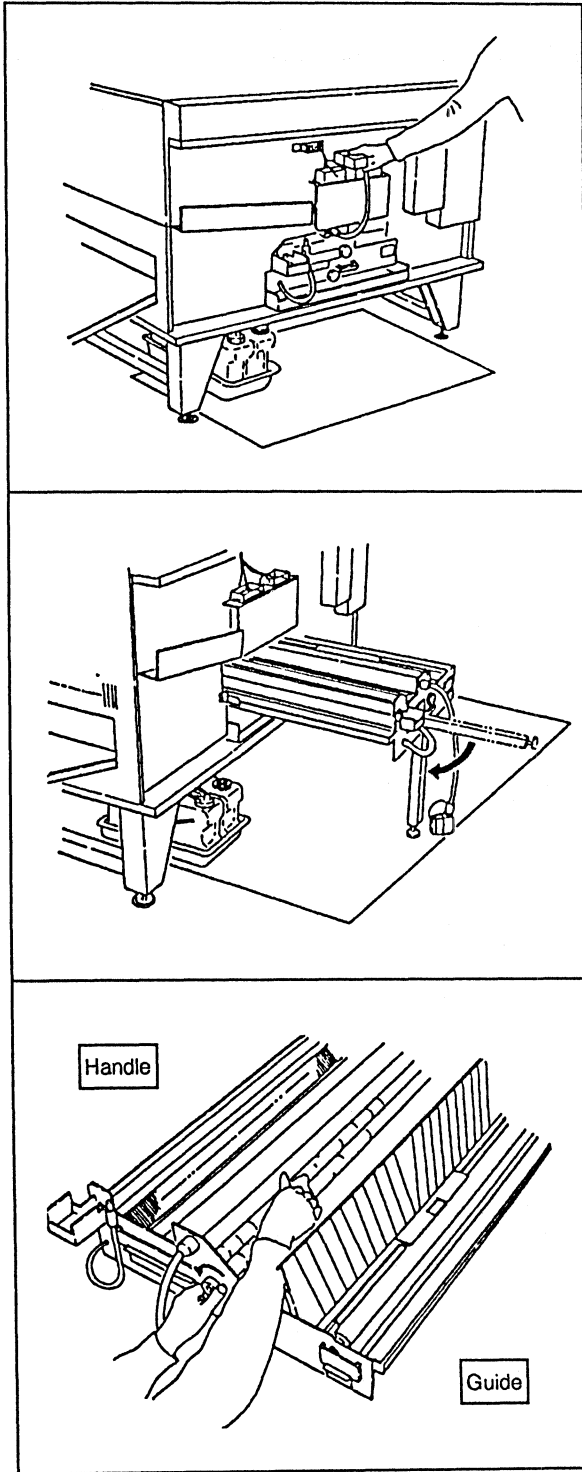

- ① Completely drain the processing solution.

Press the **A** key twice.

Press the  START key to drain the solution into the waste-solution tank.

- ② Turn the power switch OFF.
- ③ Open the front panel of the main unit, and take out the replenisher tank.
- ④ Prepare a bucket for waste fluid, and drain the rinse bath solution into the bucket with a drain hose.
- ⑤ Remove the connector and pull the processor section out.
  - \* Put the cap on after the connector is removed.
  - \* When the processor section is pulled out, processing solution may spill on the floor. Place the vinyl sheet (supplied) on the floor.
- ⑥ Pull out the stand and stabilize.
- ⑦ Stand the guide upright.
- ⑧ Carefully wipe off the solution sludge stuck to the transport section with a cloth or a sponge moistened in water.

**[Note] 1. Never use a detergent or**

## 11-2-2 Replacing the Cutter Blade

Replace the cutter either after cutting 300 plates (75 m roll, about 2 rolls) or after 30 days have elapsed, regardless of the number of plates cut.

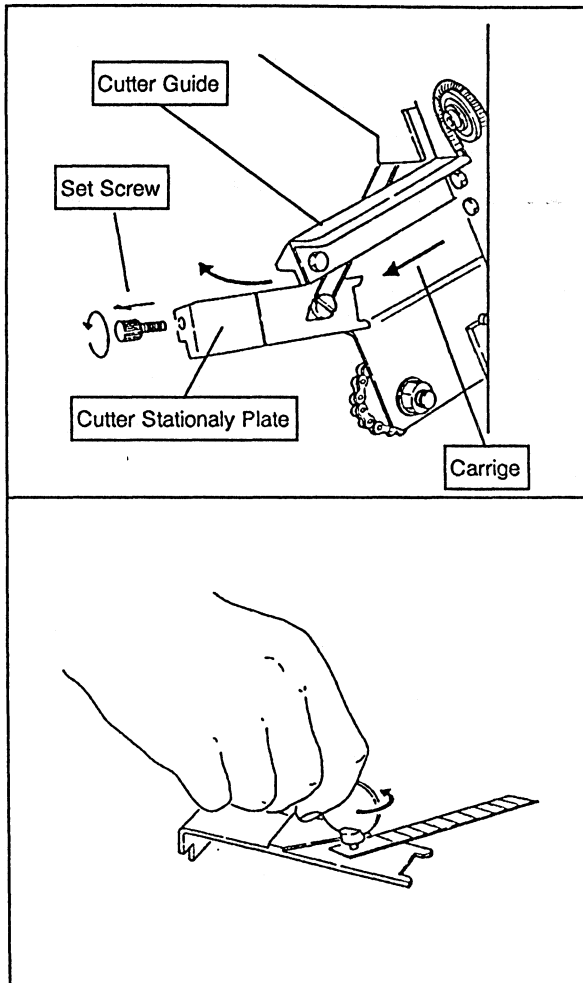

- ① Turn on the power switch.
- ② Open the front panel of the main unit, and remove the cover of the cutter section.
- ③ Remove the set screws of the cutter stationary plate.
- ④ Remove the cutter stationary plate and replace the cutter blade.
  - \* Be very careful when working at the blade side.
  - \* Use an NT cutter (blade length 85 mm/334") available at hardware stores.
- ⑤ Insert the cutter blade into the cutter guide, and mount the cutter stationary plate to the carriage.
- ⑥ Turn on the power switch.
- ⑦ Check the operation of the cutter in the "Stand By" status.  

120	+	1
-----	---	---
- ⑧ Clear the "Stand By" status.

## 11-2-3 Replacing Halogen Lamp

A 170 V, 1500 W halogen lamp is used. Allow the reflector plate to cool before replacing the lamp.

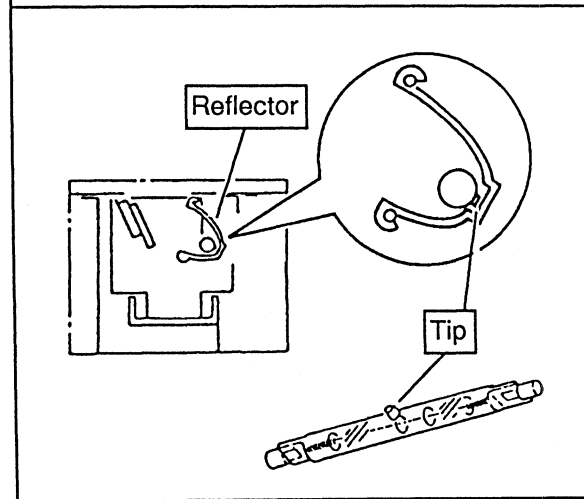
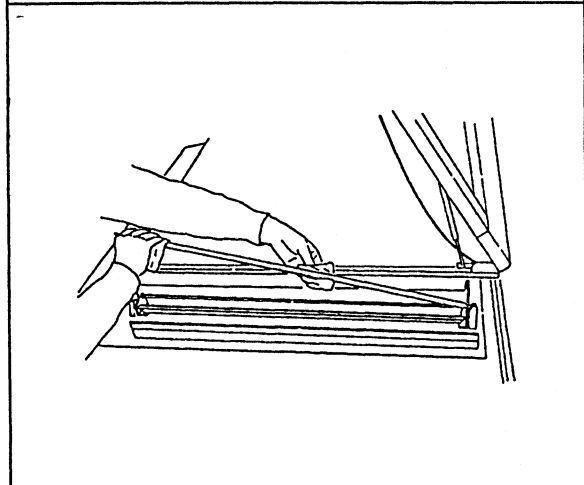
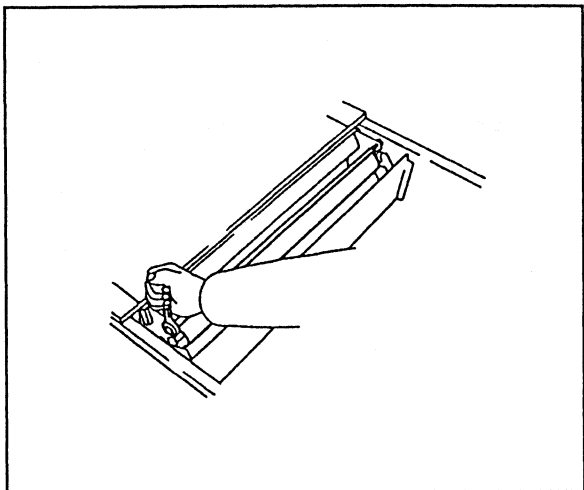

- ① Move the original setting section in the "Stand By" status.

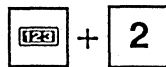

- ② Turn off the power switch.
- ③ Remove the right top cover by the (M4 × 4) screws. Remove the reflector position set screws (M4 × 2).
- ④ Hold the lamp with a clean dry cloth or gloves. Do not hold with your bare hands. If a fingerprint, oil or dirt sticks to the lamp, the life of the lamp is shortened, and uneven lighting occurs. If dirt sticks to the lamp, drop an extremely small amount of alcohol (obtainable at a drug store) onto lens paper (obtainable at a camera shop), and wipe the dirt off. \* Install the lamp so that the lamp tip and reflector face each other.

- ⑤ Turn on the power switch after replacing the lamp.

- ⑥ Check lighting of the halogen lamp in the "Stand By" status.

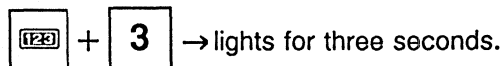

- ⑦ Return the reflector to its original position, and reinstall the top right cover.

- ⑧ Return the original setting section to the origin.

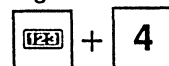

- ⑨ Clear the "Stand By" status.

## 11-2-4 Taking Care of the Copy glass

Check the copy glass every day during start operation check, since dust and fingerprints easily stick to glass.

If the copy glass is dirty, wipe off with a soft cloth and glass cleaner. Be careful to completely remove any glass cleaner.

I

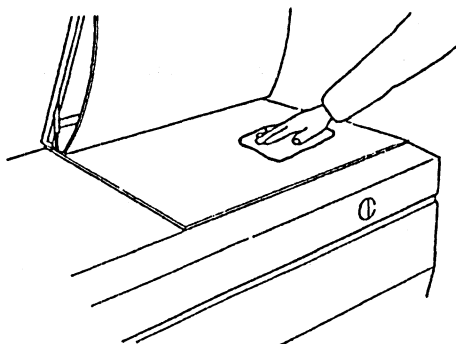

II

- ① Remove the top left cover. Open the base solution tank loading door, and pull out the base solution tank.
- ② Turn on the safety switch with the safety switch key (supplied).
- ③ Move the copy glass to the left in the "Stand By" status.

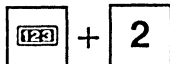

- ④ Turn off the power, and wipe the rear side of the copy glass.

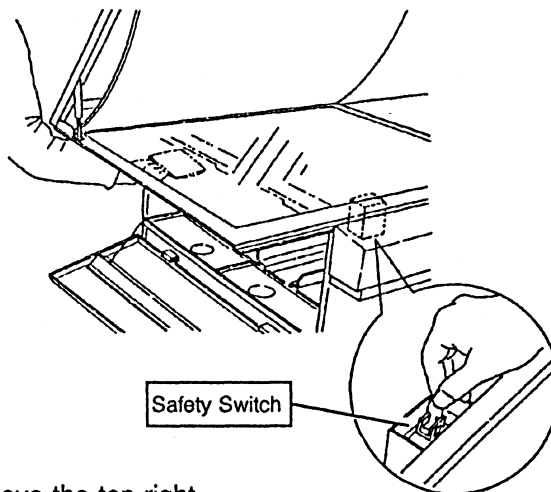

III

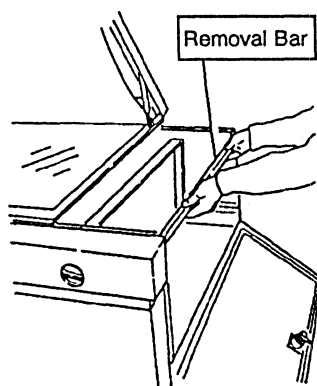

- ⑤ Remove the top right cover, open the master loading door, and detach the removal bar.
- ⑥ Turn on the power, and move the copy glass to the right.

IV

- ⑦ Turn off the power again, and wipe the rest of the glass.
- ⑧ Wipe off the safety switch key, set the base solution tank, then attach the top left cover.
- ⑨ Turn on the power, move the copy glass to the left, then attach the removal bar and the top right cover.
- ⑩ Move the copy glass to the origin.

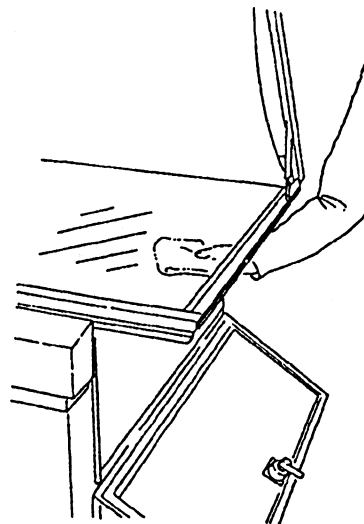

## 11-2-5 Taking Care of the Lens and Mirror Section

The lens and mirrors that are inside rarely become dirty, however after a long period of time, functioning of the optical system deteriorates due to dust in the room.

\* Lightly dust with an air brush once a month.

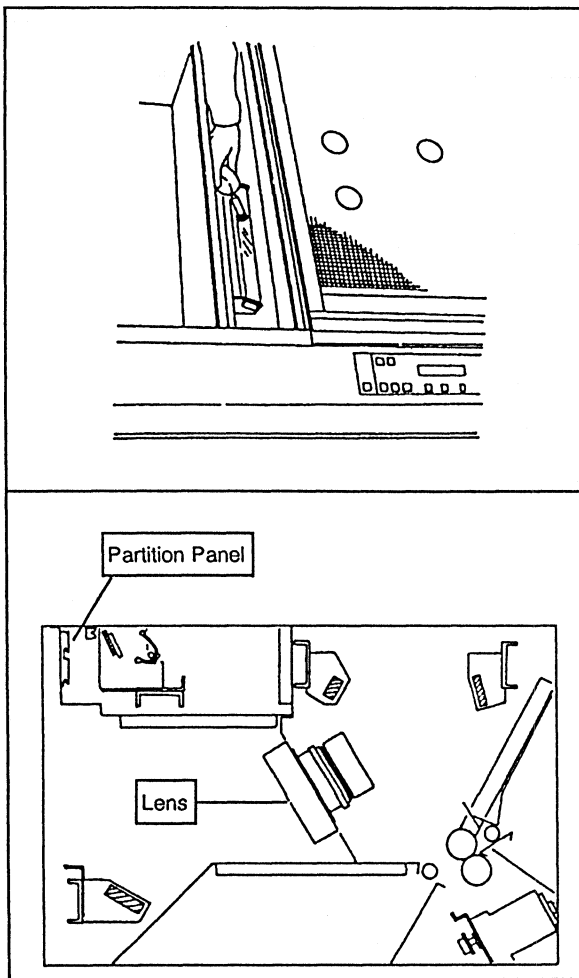

- ① Turn off the power switch.
- ② Remove the top cover at the paper discharge side, and remove the partition panel.
- ③ Clean mirror ① with an air brush.  
\* If extremely dirty, drop an extremely small amount of industrial ethyl alcohol (obtainable at a hardware store) on lens paper (obtainable at a camera shop), and lightly wipe off.
- ④ Clean mirrors (2) and (3) and lens only when extremely dirty. Regular cleaning is unnecessary.  
\* When cleaning, move the copy glass to the left in the "Stand By" status.

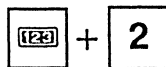

\* Remove the top right cover and clean.

## 11-2-6 Cleaning the Base Solution Tank Filter

Clean the filter if it becomes clogged.

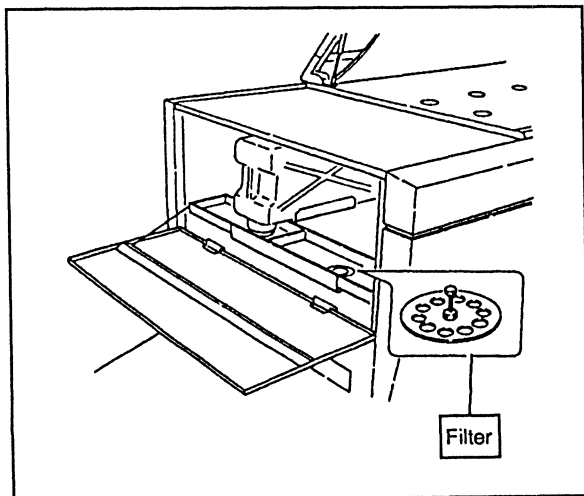

- ① Open the base solution setting door, and pull out the base solution tank.
- ② Pull out the filter and clean with water.

## 11-2-7 Cleaning the Back Filter

If the filter becomes clogged, the copy glass becomes heated, which affects photographing.  
Clean the filter once a month.

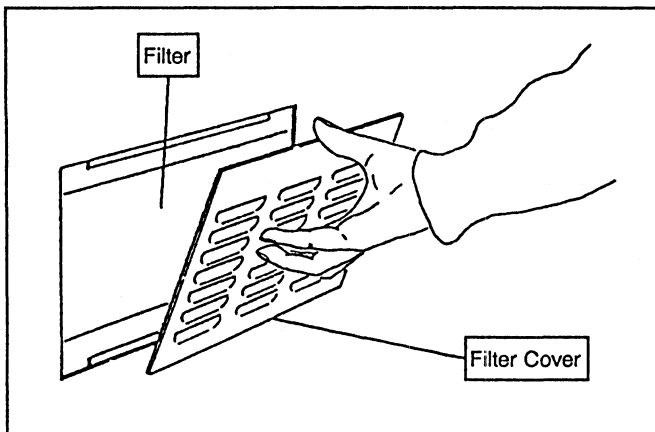

- ① Turn off the power switch.
- ② Remove the filter cover at the back of the main unit, and clean the filter.

## 11-3 Lubrication

Follow the standards below when lubricating according to the frequency of use.

- \*1. Use Shell Tellus #27 or an equivalent oil, once a month.
- \*2. Use a small amount of lubricant.

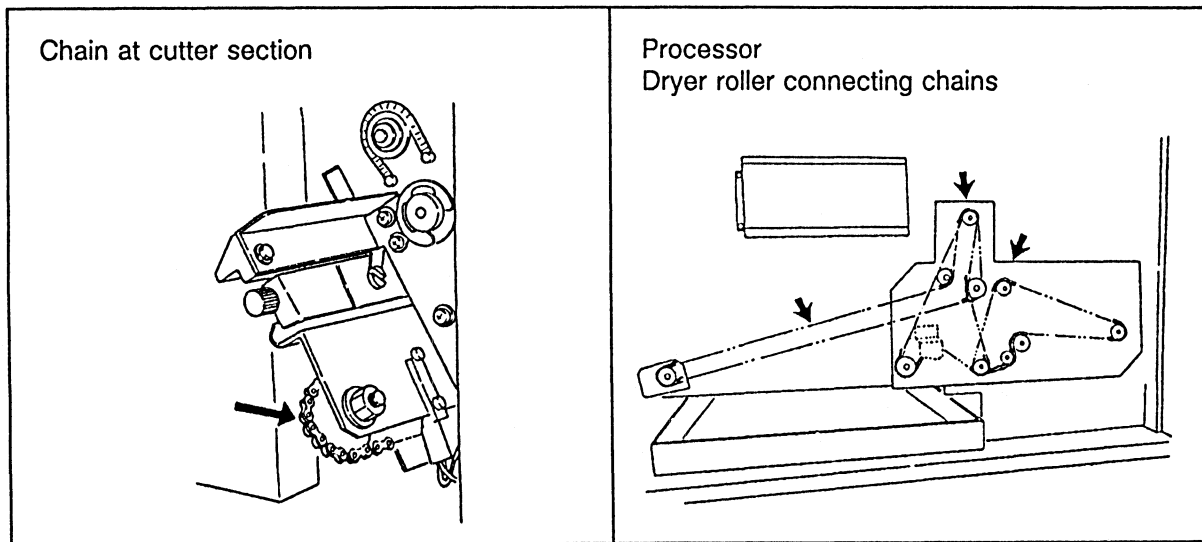

## 11-4 Fuse Locations

Fuses are located inside the distribution board.

**[Note 1]** Make sure that the power switch and original power supply are turned OFF before replacing fuses.

**[Note 2]** Do not use fuses other than ones with the same indicated capacity.

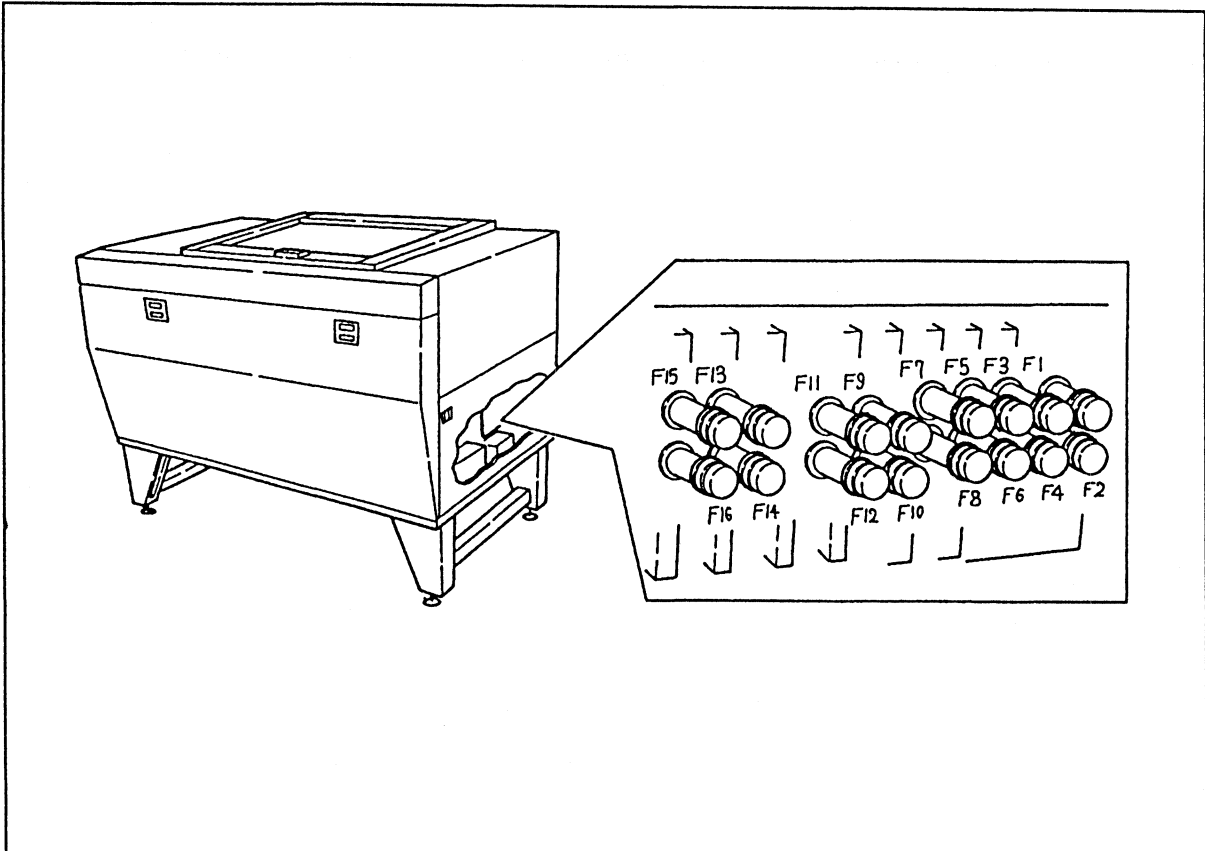

## 11-5 Ordering Parts

There are many unit components that a user can purchase and replace and only those that are available to service personnel. When ordering parts, specify the following.

- ① Whether only that part is necessary, or installation (replace) by service personnel is also necessary.
- ② Information written on the guarantee or on the name plate of the main unit.
  - i) Model Name: CP-610S
  - ii) Model Number
- ③ Necessary part name, part No. quantity, and time of delivery.

**[Note]**

- Specifications are subject to change without notice due to improvements, or specifications may differ from those listed in this instruction manual.
- Mitsubishi assumes no responsibility should a user perform remodeling or if the CP-610S is used with products of other companies.

# 12. Troubleshooting

## 12-1 Error Messages

An error message is displayed when the unit is not in normal status. Turn the power switch OFF then ON again (within about 5 sec.), and try reproduction again. If the unit still does not operate normally, contact our service personnel.

Display	Content	Check Points
① DATA ERROR	Input data backup is defective.	<ul style="list-style-type: none"> <li>• Data is reset automatically.</li> </ul>
② CUTTER FOW ERROR	<ul style="list-style-type: none"> <li>• Cutting does not end within a specified time.</li> </ul>	<ul style="list-style-type: none"> <li>• Check the cutter blade.</li> <li>• Check for a paper jam at the cutter section.</li> <li>• Contact service personnel.</li> </ul>
③ CUTTER REW ERROR	<ul style="list-style-type: none"> <li>• Cutter does not return to origin within a specified time.</li> </ul>	<ul style="list-style-type: none"> <li>• Check for a paper jam at the cutter section.</li> <li>• Contact service personnel.</li> </ul>
④ CUTTER CUT ERROR	<ul style="list-style-type: none"> <li>• Master is not cut, even after photographing ends.</li> </ul>	<ul style="list-style-type: none"> <li>• Check cutter blade.</li> </ul>
⑤ CUTTER O.P ERROR	<ul style="list-style-type: none"> <li>• Cutter is not at origin during normal operation.</li> </ul>	<ul style="list-style-type: none"> <li>• Turn the power switch OFF once, then ON again.</li> </ul>
⑥ CUTTER CHECK	<ul style="list-style-type: none"> <li>• The cutter section is abnormal.</li> </ul>	<ul style="list-style-type: none"> <li>• Contact service personnel.</li> </ul>
⑦ MASTER FEED ERROR	<ul style="list-style-type: none"> <li>• The master is not fed, even though photographing started.</li> </ul>	<ul style="list-style-type: none"> <li>• Contact service personnel.</li> </ul>
⑧ ORIG OVER RUN	<ul style="list-style-type: none"> <li>• The original setting section moved to the end after pressing the START key.</li> </ul>	<ul style="list-style-type: none"> <li>• Contact service personnel.</li> </ul>
⑨ ORIG O.P ERROR	<ul style="list-style-type: none"> <li>• The original setting section is not at origin during normal operation.</li> </ul>	<ul style="list-style-type: none"> <li>• Turn the power switch OFF once, then ON again.</li> </ul>
⑩ ORIG CHECK	<ul style="list-style-type: none"> <li>• The original setting section is abnormal.</li> </ul>	<ul style="list-style-type: none"> <li>• Contact service personnel.</li> </ul>
⑪ MASTER REMOVE	<ul style="list-style-type: none"> <li>• The end strip of the master remained inside the main unit.</li> </ul>	<ul style="list-style-type: none"> <li>• Open the front panel of the main unit, and remove the strip by hand.</li> </ul>



---

SILVER MASTER CP-610S

## **Instruction Manual**

---

No. 2375B-9109 Printed in Japan