

MITSUBISHI GRAPHIC ARTS SYSTEM

CP-50S

CONTENTS

1. OUTLINE	2
1-1 Introduction	2
1-2 Specifications	3
2. OPERATION	4
2-1 General Construction	4
2-2 Power Switch	4
2-3 Main Control Panel	5
2-4 Processor	6
2-5 Copy Holder	7
2-6 Lens and Mirrors	8
2-7 Photographing Section	9
3. PHOTOGRAPHING	12
3-1 Photographing Procedure	12
3-2 How to Determine Standard Exposure	12
4. MAINTENANCE	14
4-1 Inspection at Start-up	14
4-2 Inspection at Shut-down	14
4-3 General Care	14
4-4 Ordering and Replacement of Parts	18
4-5 Trouble and Remedies	18
4-6 Wiring Diagram	21

1. OUTLINE

1-1 Introduction

We at Mitsubishi are very grateful to you for selecting the Silver Master Platemaker CP-50S. The Silver Master Platemaker CP-50S is a completely new multi-functional platemaking system which, in combination with Silver Master R11, produces offset masters directly from the copy with a simple operation, eliminating the need for any intermediate film process.

This operation manual is intended to enable you to enjoy the system's superior features for a long time. For information on printing method, please refer to our separate booklet, "Silver Master Technical Guide."

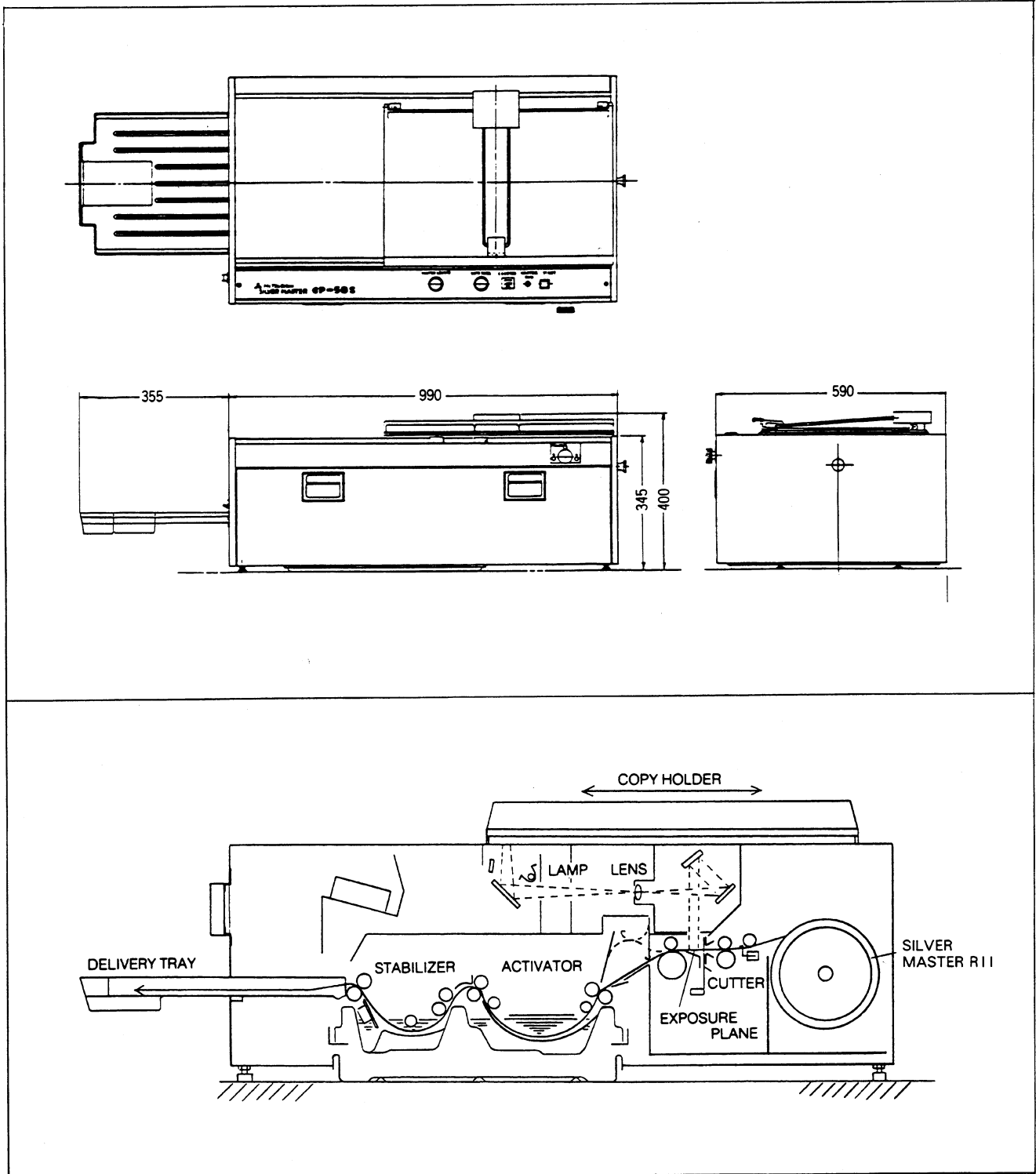

1-2 Specifications

Item	Specifications
Master width	229mm (9"), 254mm (10"), 279mm (11")
Master length	370mm to 480mm continuously variable
Effective image area	279mm × 430mm
Blank exposure size	279mm × 480mm
Exposure method	Slit exposure
Lens	Focal length = 150mm, F 11
Magnification	100% (1:1)
Cutter	Slide cut type
Exposure control	Power supply thyristor, with light-level control dial
Light source	Halogen lamp (80V, 600W × 1) with constant-voltage circuit
Copy loading	Copy holding with compression mat on the machine top, with the copy image side down
Processor tank capacity	Activator tank 3 liters Stabilizer tank 2 liters
Replenishing tanks	Activator replenishing tank 0.5 liters Stabilizer replenishing tank 0.5 liters constant level method
Processor heater	250W panel heater for temperature control at the activator tank
First master making time	65 to 78 sec (master length = 480mm)
Cycle master making time	48 to 58 sec (master length = 480mm)
Installation method	Table top mounting
Machine dimensions	990(W) × 590(D) × 400(H) mm
Weight	70 Kg
Electricity	100VAC, 1.2 KW

* These specifications are subject to change without notice for improvement

2. OPERATION

2-1 General Construction

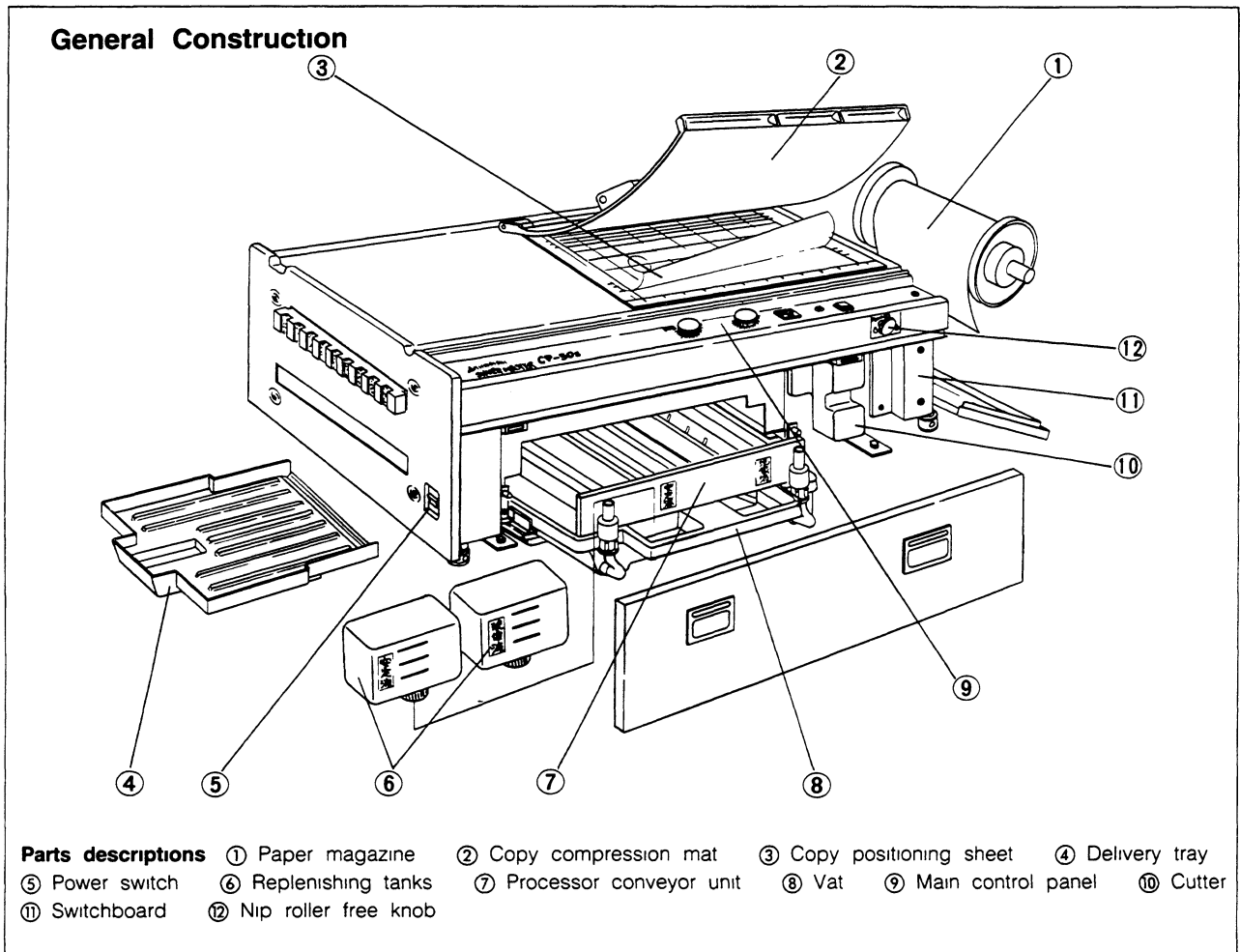

2-2 Power Switch

① POWER switch

When this is turned on, the operation circuit, processor motor and panel heater are energized and the system is ready for operation

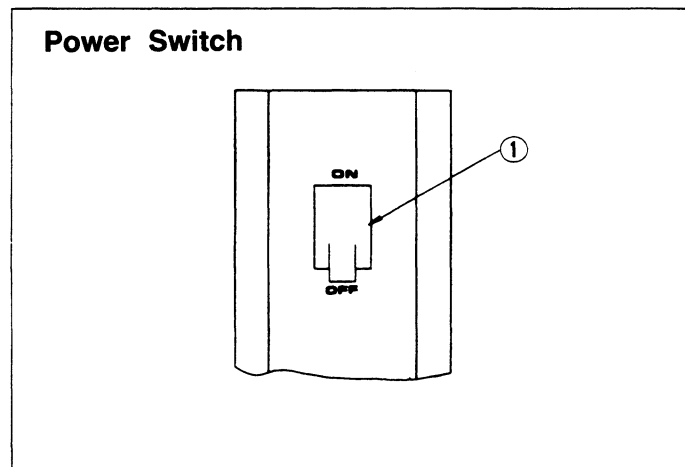

2-3 Main Control Panel

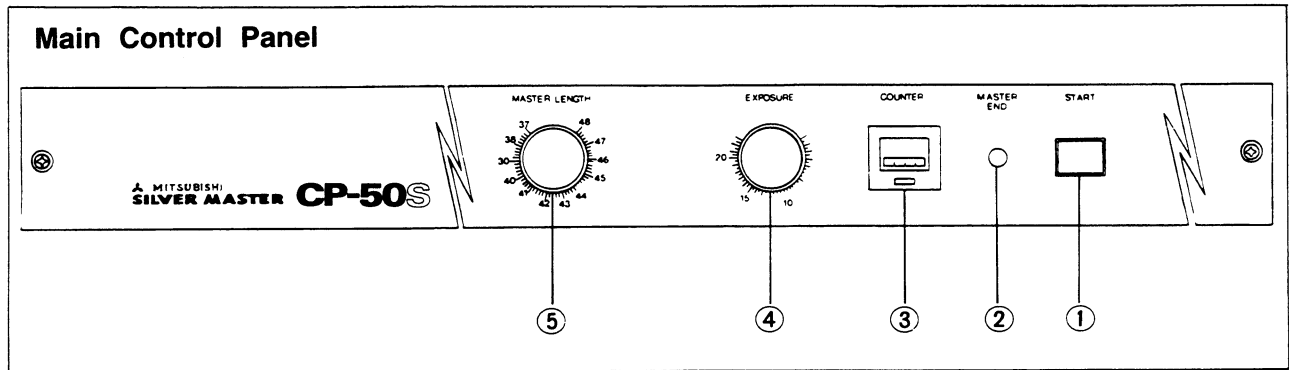

① START button

The START button switch initiates a series of operations exposure, paper feed, cutting, developing, stabilizing, drying and delivery (output)

The indicator of this button switch is off during photographing operation. When the indicator comes on completion of the photographing operation, the machine becomes ready for another exposure.

② MASTER END pilot lamp (red)

The MASTER END pilot lamp lights when the Master roll loaded in the magazine runs out. The lamp also lights up if the Master roll is improperly loaded. In such cases, reload the Master roll properly.

The START button switch does not work while this pilot lamp is on.

③ COUNTER

The COUNTER indicates the number of masters produced. Reset the counter to zero by pushing the reset button after changing the activator or loading a new master paper roll.

④ EXPOSURE dial

The EXPOSURE dial is used to control the amount of light exposure according to the copy density or the type of copy. This dial controls the light source lamp voltage, or the brightness of the lamp to obtain the optimum light exposure. Decrease the dial setting for copies with low density and increase it for copies with high density (dark text or background).

⑤ MASTER LENGTH dial

While being exposed, paper is fed by the length set on the MASTER LENGTH dial. After the exposure/feeding, the master paper is cut automatically. The master length can be set continuously in the range from 370 to 480 mm.

2-4 Processor

When the POWER switch is turned on, the drive motor starts to drive the rollers of the conveyor unit and the panel heater begins to work

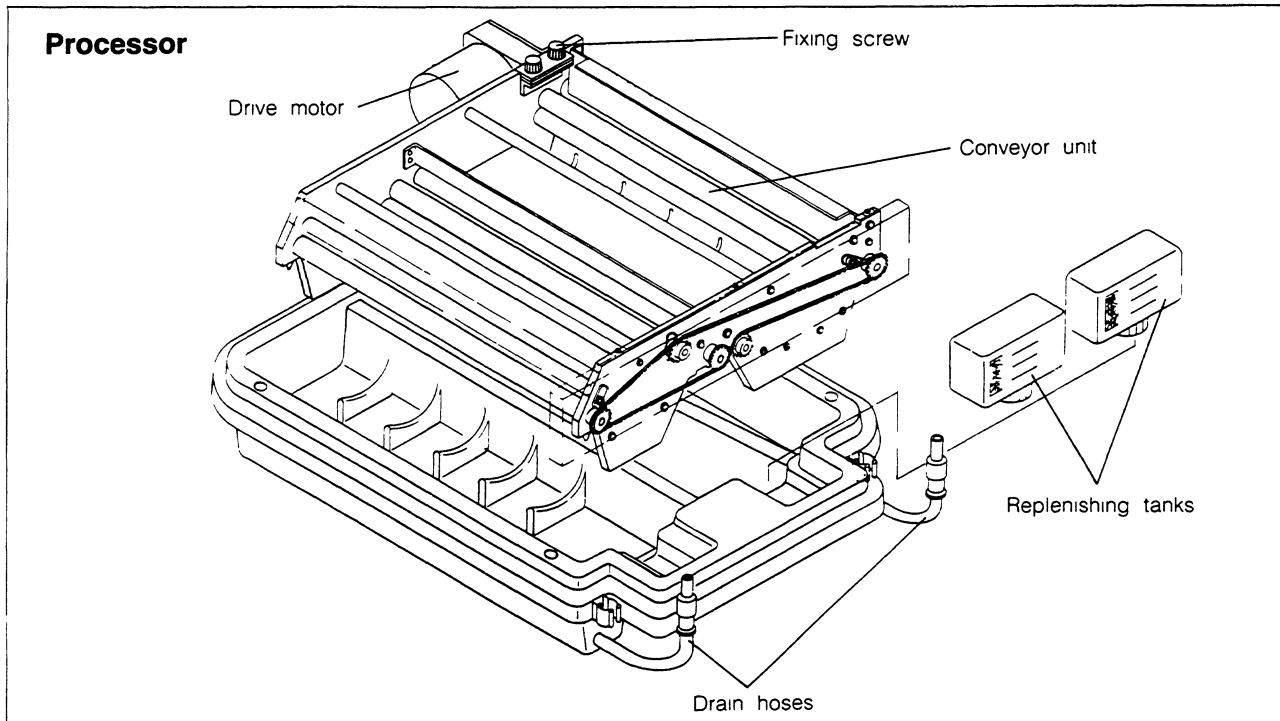

A. Preparation of processing solutions

- Take off the processor cover and unhook the processor, and the processor can be pulled out of the main body
- The processor is composed of an activator tank and a stabilizer tank, across both of which a conveyor unit lies. The activator tank is equipped with 250W panel heater with thermostat which keeps the activator temperature at a constant level (approx 30°C) during operation

After the machine is not in use for a long period of time, the rollers of the unit may not turn smoothly because they stick to each other. In such cases, turn the rollers by hand before starting the machine.

- For preparing the processing solutions, use specially made measuring cups
- Use 30 to 35°C hot water when the temperature of water is low in winter
- Be sure to handle the processor gently when taking it in or out

Activator Tank (capacity 3 liters)

Prepare activator by mixing SLM-AC with water in the ratio of 1:1

- ① Add 1.5 liters of water to 1.5 liters of SLM-AC (undiluted solution), exclusive activator for SILVER MASTER, and pour the mixture into the activator tank after thoroughly stirring it
- ② Pour the activator, prepared in the same ratio (1:1), into the activator replenishing tank (0.5 liter) and mount the tank properly on the unit

Stabilizer Tank (capacity 2 liters)

Prepare stabilizer by mixing SLM-ST with water in the ratio of 1:3

- ① Add 1.5 liters of water to 0.5 liter of SLM-ST (undiluted solution), exclusive stabilizer for SILVER MASTER, and pour the mixture into the stabilizer tank after thoroughly stirring it
- ② Pour the stabilizer, prepared in the same ratio (1:3), into the stabilizer replenishing tank (0.5 liter) and mount it properly on the unit

Adding the processing solutions

The replenishing tanks should always contain a sufficient quantity of processing solutions properly prepared. As the replenishing solution is exhausted, the liquid level in the processing tank is lowered, resulting in accelerated fatigue of the solution and deterioration of the master quality.

Changing the processing solutions

Refer to the paragraph of "General Care" (P 10)

Caution in handling chemicals

- ① Be careful never to drink or get into eyes processing chemicals (In case of such accidents check with a doctor)
- ② When chemicals splash onto skin or cloths, immediately wash with running water
- ③ Use chemicals properly according to instruction
- ④ Keep chemicals out of reach of children

2-5 Copy Holder

Don't put anything on the top of the machine because the copy holder moves from right side to left side. Never touch the copy holder during its movement.

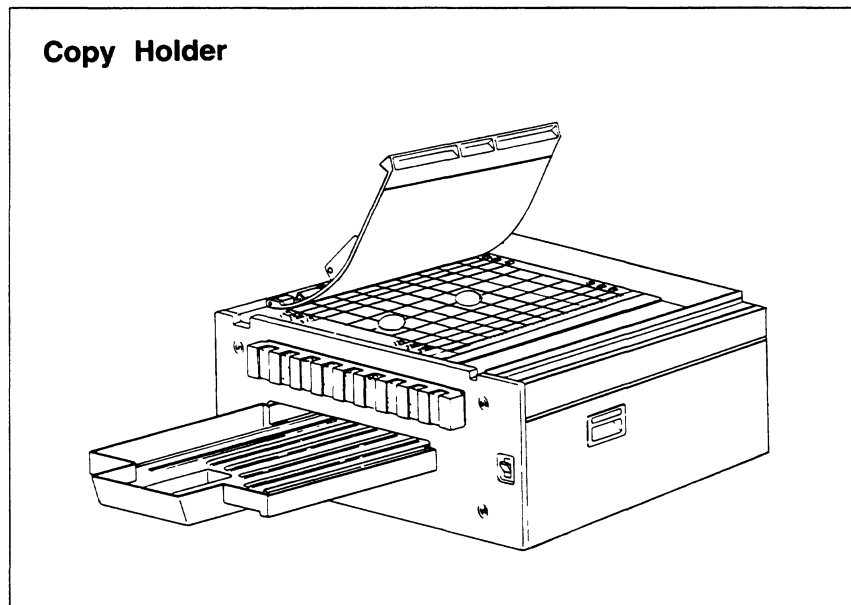

2-5-1 Loading the original copy

- ① Raise the copy frame slowly holding its handle, and it will be stopped in the specified position by means of spring (Hold the handle until the frame is stopped)
- ② Place the original copy between the positioning sheet and the copy glass (Refer to "B Positioning the original copy") Close the copy frame gently

CAUTION

Don't handle the copy frame roughly especially in raising or lowering it

Positioning sheet

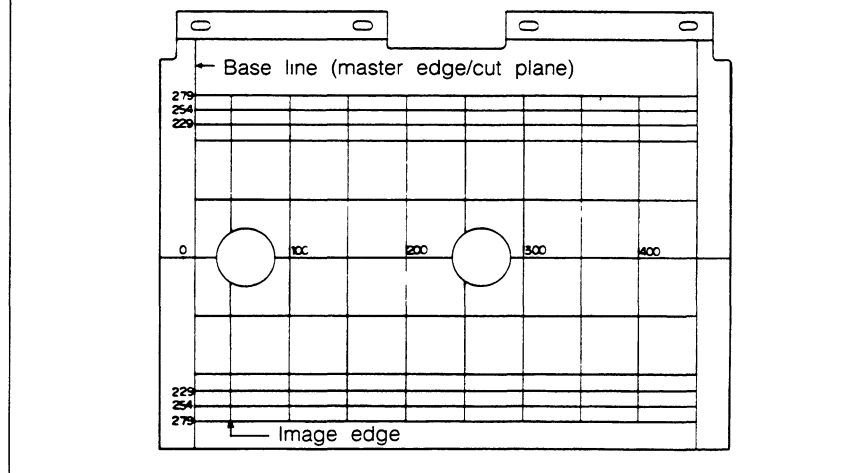

2-5-2 Positioning the original copy

- The original copy should be centered in the cross directions as shown in the figure on the sheet
- The edge of the effective projected image area is 20 mm from the paper edge. Put the copy left edge along the positioning sheet reference line
- For centering the copy, use the positioning sheet graduations
- The positioning sheet has round holes for accurate and easy positioning

2-6 Lens and Mirrors

Lens and Mirrors

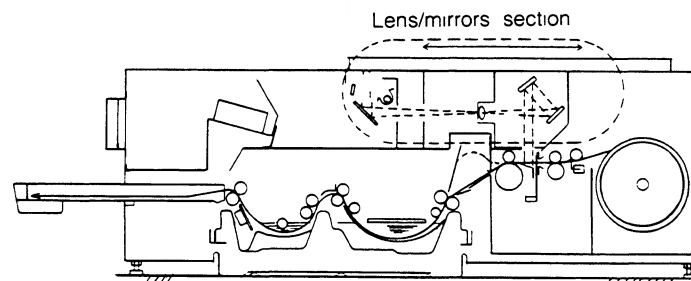

Detail of the Lens and Mirrors

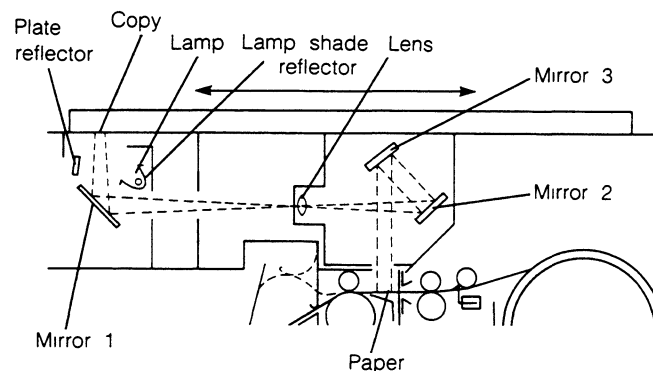

Principle of Photographing

- As the lamp lights up, the direct light from the lamp and the light reflected from the reflectors irradiate the copy plane
- The light from the copy, or the image, is reflected by mirror 1 and goes through the lens
- After passing through the lens, the light is reflected by mirror 2 and then mirror 3 to be cast on the Master
- The lens and mirrors are fixed, the copy holder moves from right to left. As the Master moves synchronously with the copy holder travel, it is irradiated by the light from the copy image. Thus the image is reproduced on the Master
- This machine uses $f = 150 \text{ mm}$ lens (F 11)
- This machine should be installed in a dust-free and less humid place because it incorporates mirrors
- Don't touch the lens or mirrors with bare hands especially when replacing the lamp or cleaning the inside of the machine

2-7 Photographing Section

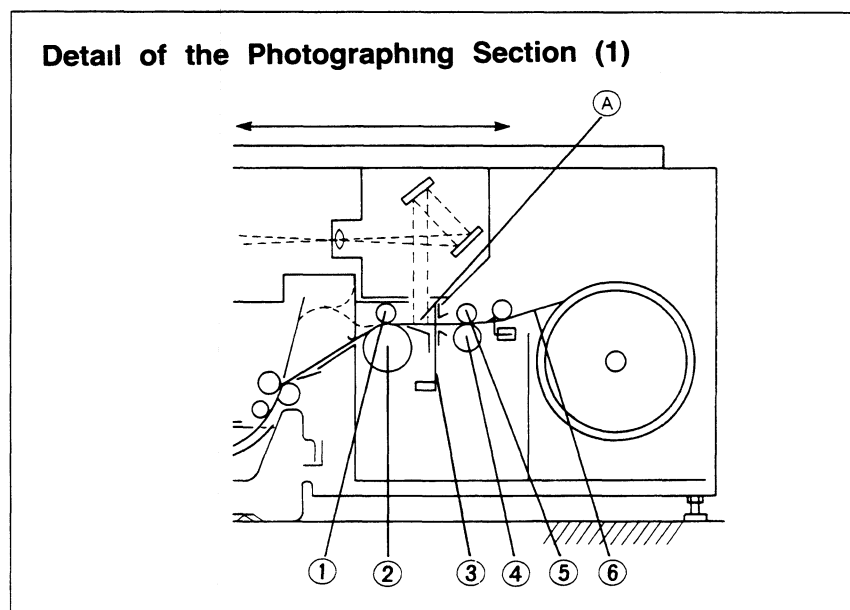

Master, kept level by means of the four rollers ①, ②, ④ and ⑤, is fed synchronously with the copy holder travel while being exposed. Then, the master paper is transported to the processor.

When the exposure is completed or the Master has been fed by the length set on the MASTER LENGTH dial, the Master is stopped and cut with the cutter.

Detail of the Photographing Section (2)

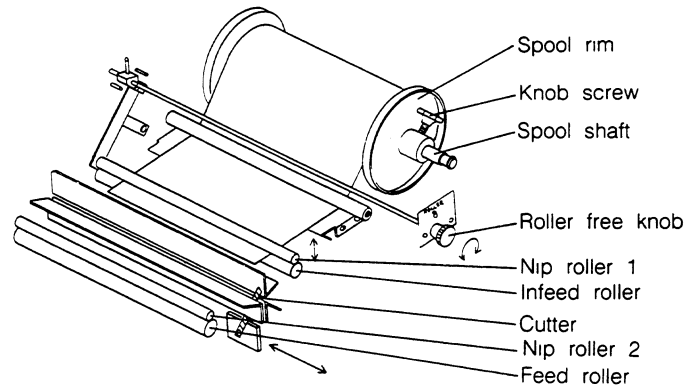

Master Magazine

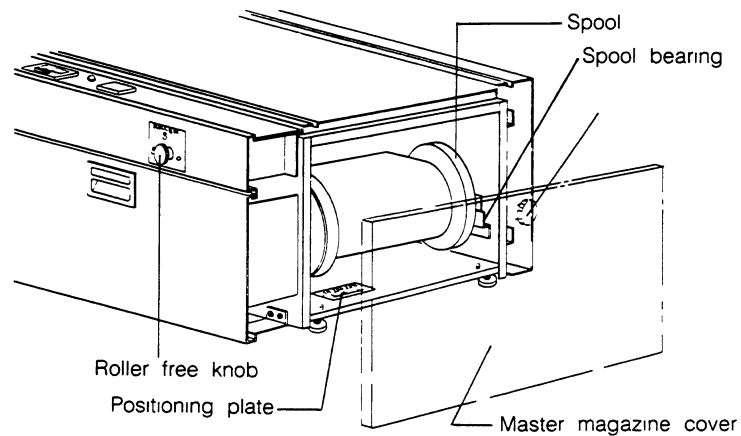

2-7-1 Loading master paper

- ① Turn the knob of the Master magazine cover and pull it toward you, and the cover opens
- ② Fit the spool rim to the spool shaft guide line depending on the width of the Master (229, 254 or 279 mm) in use and secure it with set screw. The set screw holes are provided on the spool shaft reference side
- ③ Pass the spool shaft through the Master roll core hole (As you face the machine, the reference side is on the left)
- ④ Fit the other spool rim to the spool shaft and secure it with set screw
- ⑤ Put the spool loaded with paper on the spool bearings in place referring to the positioning plate
- ⑥ Turn the nip roller free knob to the right to symbol ① (⊙) and the nip roller 1 goes up to leave the infeed roller
- ⑦ Pass the paper between the infeed roller and nip roller 1 and, feed it further to the feed roller by hand (Since the feed roller is in contact with the nip roller 2, you can feel the touch of the paper edge to the rollers)
- ⑧ Then, move the paper back by approx 10-20 mm and return the nip roller free knob to the former position symbol ② (⊗). The nip roller 1 goes down to touch the infeed roller
- ⑨ Switch on the POWER switch, and the START pilot lamp (green) lights. If the START indicator does not light but the MASTER END pilot lamp lights, the paper is not in the exposure plane. If so, take the above steps from ⑥ to ⑧ again

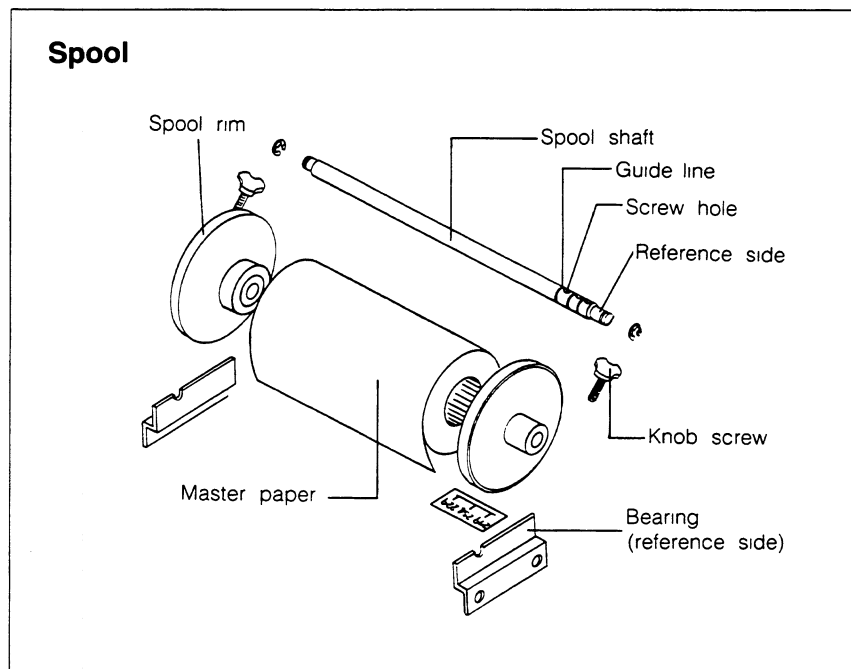

2-7-2 Roller free knob

The nip roller free knob provided with the pointer can be rotated both clockwise and counterclockwise. By using the knob, the position of the nip roller 1 may be changed as indicated by the symbols depending on situation.

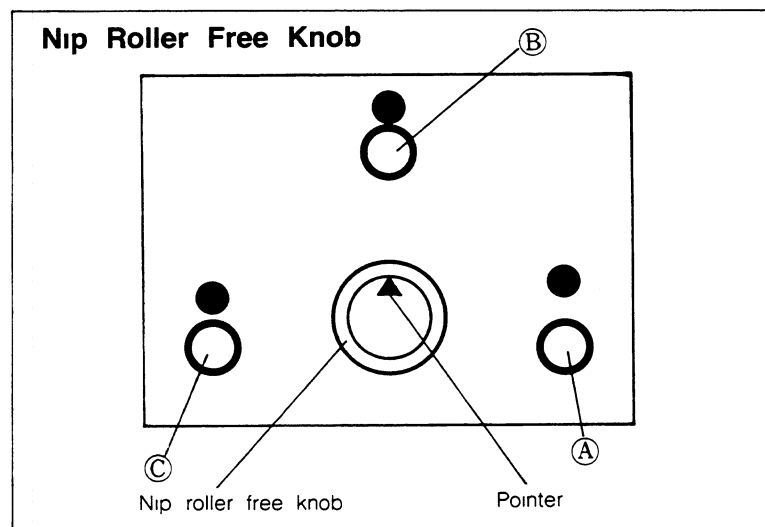

- Ⓐ ♂ The nip roller 1 is off the infeed roller with a wide gap. To load paper, set the dial to this position.
- Ⓑ ♂ The nip roller 1 comes in touch with the infeed roller. To feed paper (for photographing), set it to this position.
- Ⓒ ♂ The nip roller 1 is off the infeed roller with a small gap. When the machine is expected not to be used for many hours, set it to this position to prevent fogging or wrinkles due to roller pressure.

3. PHOTOGRAPHING

3-1 Photographing Procedure

Satisfactory photography cannot be produced unless the following conditions are met. Carry out the checks stated below before starting the machine.

① Conditions for photographing

- 1 Processing solutions are prepared
 - 2 The MASTER END lamp (red) is out
 - 3 The nip roller free knob is set to symbol Ⓑ (Ⓢ)
 - 4 The START indicator (green) is on
- Turn on the power approx 30 minutes before operation (The activator temperature should rise to the prescribed level. The liquid temperature rises by approx 1°C per minute.)
 - Never put anything on the top of the machine since the copy holder moves longitudinally.

② Positioning the original copy

Place the copy with its image side down and set it in the desired position, using the graduations of the positioning sheet.

③ Setting the master length

Set a prescribed length (370-480 mm) on the MASTER LENGTH dial.

④ Exposure control

Adjust the exposure (brightness of the light source) for each copy with the EXPOSURE dial.

⑤ Start

Push the START button and photographing will be automatically performed to produce a master.

After a master is produced, the START indicator (green) lights up.

- ⑥ When the machine is expected not to be used for many hours or until tomorrow morning, turn the nip roller free knob counterclockwise to set it to symbol Ⓒ (Ⓢ). This prevents paper from being fogged or wrinkled due to roller pressure.

3-2 How to Determine Standard Exposure

Since the SILVER MASTER RII is coated with silver-halide emulsion, its sensitivity may somewhat vary among lots. Each carton bears a lot number. Before using a new lot, check its sensitivity.

Under-exposure may cause thickened images or toning on backgrounds.

Over-exposure may cause too thin images or lost images. Optimum exposure is essential for SILVER MASTER RII to deliver the best performance.

3-2-1 How to Determine Standard Exposure Time

- ① The CP-50S is supplied with a test chart and a standard print sample. Make an exposure of the test chart and compare it with the print sample to determine optimum exposure.
- ② Adjust the EXPOSURE dial so that silver deposit starts with the step marked with a circle in the test chart.
- ③ The corresponding exposure is referred to as Standard Exposure for the test chart.
- ④ Using this Standard Exposure Time for the test chart as a guide, determine the optimum exposure for each copy. For such copies as clean proof (typed) and phototyped matter, increase the amount of exposure by 10% to 15%. For line work, decrease the amount of exposure.

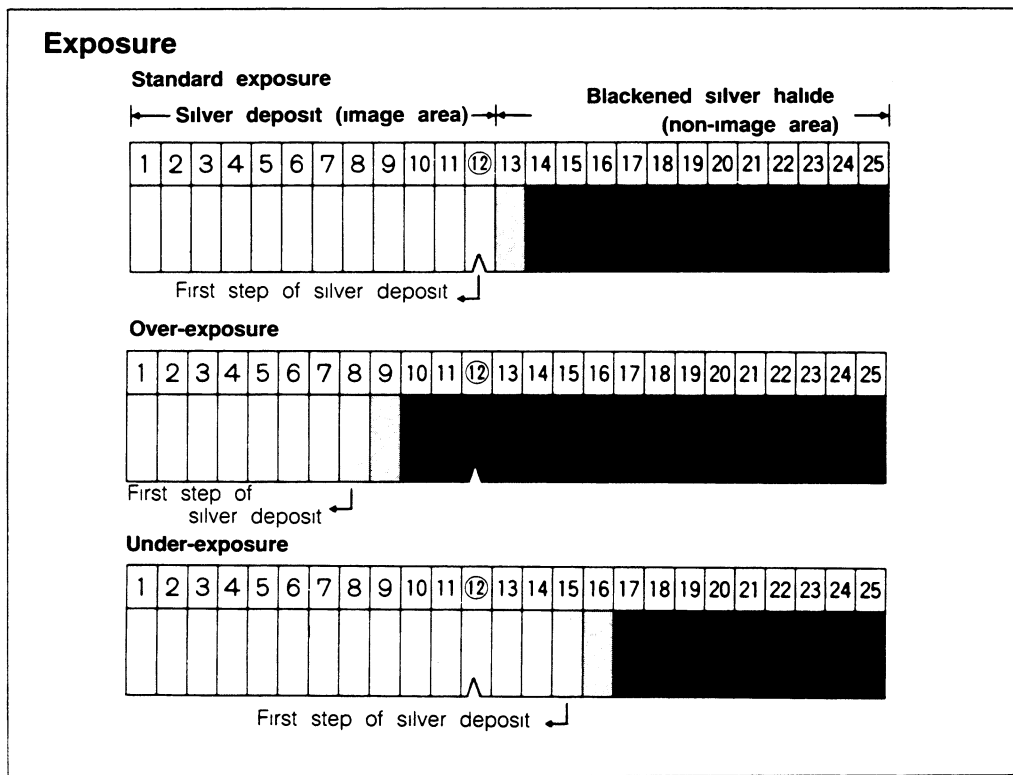

3-2-2 Focus

The focus is thoroughly checked before shipment. However, recheck it, when necessary, in accordance with the following procedure:

- Print the resolving power chart contained in the test chart and compare the print with the resolving power standard sample to judge the focus accuracy
- The amount of exposure should be a little larger than the standard one
- If the print is equivalent to or better than the resolving power standard sample, the focus accuracy is accepted
- The resolving power should be 8 lines/mm (Since this resolving power chart is a reproduction, it does not indicate absolute values)

CAUTION

The standard print sample may fade with time. So, keep it in a dark place such as a desk drawer.

4. MAINTENANCE

To maintain satisfactory operation of the SILVER MASTER CP-50S, run routine checks as follows

4-1 Inspection at Start-up

- ① Plug in the machine and turn the POWER (camera) switch on the sub-control-panel to On
- ② Turn the nip roller free knob to symbol Ⓑ(Ⓢ)
- ③ Confirm that the copy glass and mirrors are not scratched or stained
Take special care to keep the glass clean since a stained glass seriously affects the image quality
- ④ Confirm that the processing tanks and replenishing tanks are filled properly
- ⑤ Confirm that the START indicator on the main control panel is on
- ⑥ Confirm that there is no trouble in a series of automatic operations
- ⑦ When a new processing solution has been put in or the paper roll has been replaced with a new one, it is advisable to photograph the test chart in order to check overall exposure condition

4-2 Inspection at Shut-down

- ① Switch the POWER (camera) switch on the sub-control-panel to OFF and disconnected the power cord from the outlet
- ② When the machine is expected not to be used for many hours, turn the nip roller free knob to symbol Ⓒ(Ⓢ)
- ③ Cover the copy glass with the copy compression mat to keep the glass surface free from dust

4-3 General Care

4-3-1 Changing the processing solutions

One fill of activator and stabilizer is capable of processing 200 plates of B4 format. In two weeks after preparation of the solutions, change the solutions regardless of the number of plates processed so far. The processing tanks are located inside the machine. Keep them clean.

- ① Turn the POWER (camera) switch to OFF
- ② Remove the front cover from the main body and pull out the processor a little
- ③ Take off the replenishing tanks
- ④ Take out the drain vat and put the drain hose ends into the vat to drain the tank
- ⑤ Return the drain hoses to their original positions after the processing solutions are all drained
- ⑥ For the method of disposing of used solutions, refer to the separate brochure, "The Silver Master System and Environmental Issues "

4-3-2 Cleaning the tanks

After changing activator and stabilizer, wash the tanks in accordance with the following procedure without fail.

- ① Disconnect connector J3
- ② Pull out the entire processor and move it to a place where access for cleaning is easy
- ③ After disconnecting the drive motor cable connector, loosen the two knob screws to remove the motor

- ④ Dismount the conveyor unit from the tanks
- ⑤ Wash the tanks and the conveyor unit with water thoroughly. Carefully wipe away the dregs with a damp cloth or sponge
- ⑥ As the synthetic rubber used in the rollers of the conveyor unit is not heat-resistant, wash it with hot water of less than 40°C
Any detergent or polishing sand must not be used
If the metal guides of the conveyor unit are very dirty, masters may be scratched. Wash them with water and wipe dry. Then, polish them with a soft cloth using metal polishing powder until their surfaces are lustrous.

CAUTION

- ① The care described above is basic for obtaining masters of good quality. Therefore, carry it out scrupulously.
- ② If the activator and stabilizer were put in mistakenly for each other, take the following measures. Be careful since the solutions have an antipathy to each other.
 - 1) Discharge the activator and stabilizer separately
 - 2) Wash the processing tanks and conveyor unit with water
 - 3) Pour activator and stabilizer in the respective tanks correctly

4-3-3 Replacement of the cutter blade

If more than thirty days have passed since blade replacement, replace regardless of the number of cuts made. Replace the blade in the following manner.

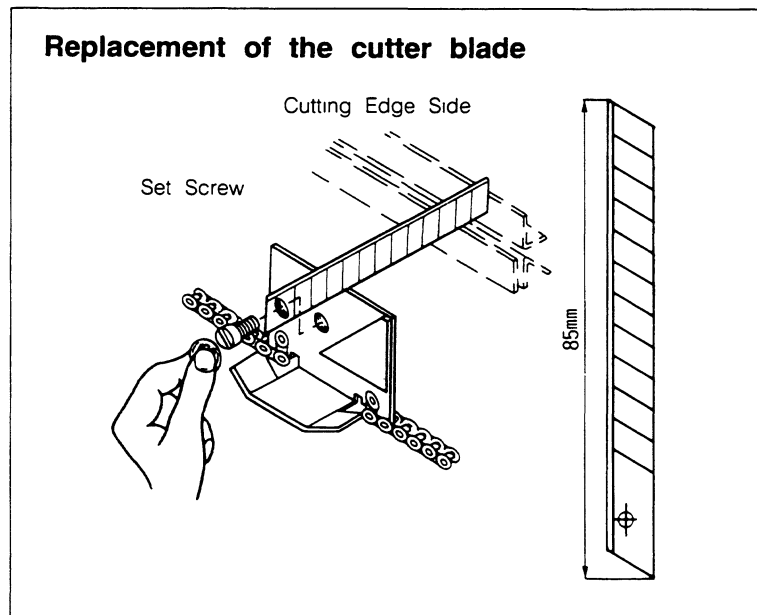

- ① Turn the POWER switch on the sub control panel to OFF
- ② Remove the front cover
- ③ Remove the cutter cover (Pull the cover a little strongly toward you, and the cover will come off)
- ④ Use NT cutters available on the market. Never touch the cutting edge
- ⑤ Fasten up the set screw using a coin or the like

4-3-4 Replacement of the halogen lamp

Replace the halogen lamp after the lamp and reflectors have cooled down

- ① Set the MASTER LENGTH dial to the maximum length (480 mm) and depress the START button
- ② As soon as the copy holder reaches the leftmost position, turn the POWER switch to OFF
- ③ Loosen the four M4 screws to remove the magazine-side top cover

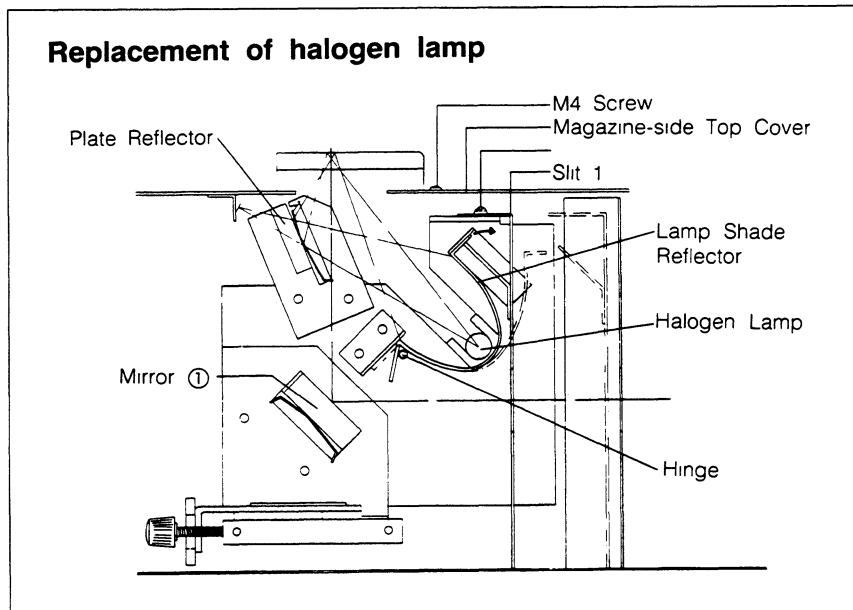

- ④ Remove the M4 screw securing slit 1
- ⑤ Holding the lamp shade reflector by hand, dismount slit 1
- ⑥ One side of the reflector is secured with the hinge, so the reflector opens in the direction of the arrow
- ⑦ Hold the lamp with a dry clean cloth or gloves on your hand and install it
 - The lamp base is of the bayonet type
 - Take enough care not to warp the reflector
 - The lamp, when stained with finger marks or smeared, will become opaque. Clean the stained lamp with lens paper (available at general camera stores) moistened with a small quantity of industrial ethyl alcohol
 - Never touch the insides of the lamp shade reflector, plate reflector and mirror 1 with bare hands

4-3-5 Replacement of the auxiliary exposure lamp

The auxiliary exposure lamp is provided near the lens to correct under-exposure at both ends of the master

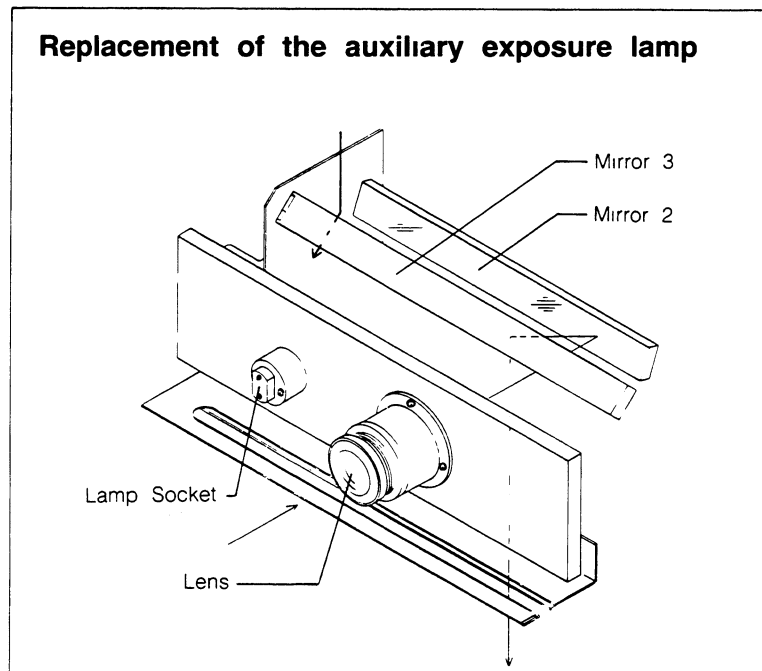

- ① As when replacing the halogen lamp, remove the magazine-side top cover
 - ② Then, the parts as shown on the left in the figure will appear. Insert your hand in the direction of the arrow and replace the lamp
- The lamp base is of the screwing type
 - Never touch mirrors 2 and 3 with bare hands

4-3-6 Handling and care of the lens and mirrors.

The lens and mirror surfaces, being soft, should be handled with the utmost care not to cause scratches or stains. Do not wipe them often.

- Lightly brush the mirror with the air brush (supplied as a standard part) every month
- If the lens is heavily dirty, wipe it gently with lens paper (available at general camera stores) moistened with a small amount of industrial ethyl alcohol (available on the market). Avoid strong rubbing or forcible removal of foreign matter so as not to cause scratches.

4-3-7 Care of the copy glass

As the copy glass is liable to be stained with dust or finger-marks, inspect it daily. If stained, wipe it with a soft cloth using a glass cleaner (available on the market), taking care not to leave the cleaning agent behind.

4-3-8 Lubrication

The required frequency of lubrication depends on the frequency of use, but generally the following frequency is recommended.

- ① Processor chain
Draw out the processor and lubricate weekly
- ② Cutter chain
Open the cover of the photographing section and lubricate monthly
Use SHELLTHERUS 27 or equivalent
- ③ Processor motor gear
Draw out the processor and lubricate it. Use Daphne Colonex Grease No 2

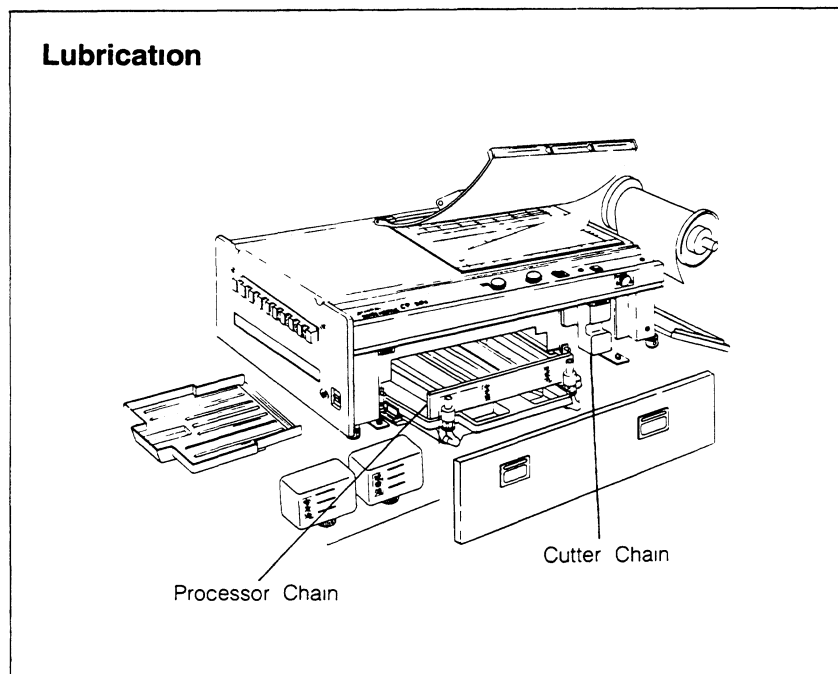

4-4 Ordering and Replacement of Parts

There are various constituent parts, some of them can be replaced by customers while others must be replaced by trained service personnel. When ordering parts, let us know the following information:

- ① Whether only parts are required or both parts and installation (replacement) service are required
- ② The information given in the certificate or the nameplate of your machine
 - Type (CP-50S)
 - MFG NO
- ③ Descriptions of parts and quantities required, date of delivery

CAUTION

- The specifications are subject to change without notice
- We assume no responsibility for troubles caused by any modifications made by the customer or by the use of another maker's equipment or parts with the machine without our approval

4-5 Troubles and Remedies

With a correct understanding of normal operations, clearly grasp the nature of the trouble which has arisen. Basic remedies are listed below.

Check systematically and, if the trouble can not be corrected, contact our agent for advice.

CAUTION

When checking the electric circuit for fuse replacement or other purposes, turn the POWER (camera) switch on the sub-control-panel to OFF.

	Trouble	Probable Cause	Remedy
1	Machine not powered up	Power supply to camera Blown fuses	Check the 100 VAC, 1 2 KW power source Turn on no-fuse breaker Replace fuses F1 and F2 (5A)
2	Processor won't work	Blown fuses Connector	Replace fuses F3 and F4 (1A) Check connector J3 and J4
3	The temperature of processing solutions won't rise	Connector Defective panel heater	Check connector J3 and J5 Replace it if necessary
4	Machine won't start	MASTER END indicator is on START indicator is out Power switch is off	Load a new paper roll Check connector J7 Check if the cutter is in the original position Check microswitch LS3 and LS6 Check connector J6 and J8 Check if copy holder is in the original position Check relay Ry2 Check light control PCB
5	Copy holder won't move	Defective relay Ry1 Microswitches malfunctioning Defective motor Drive steel tape broken or slipping	Check relay Ry1 Check microswitch LS4 Check connector J11 Check microswitch LS5 Check the motor and capacitor Check the steel tape
6	Copy holder won't return	Microswitch malfunctioning	Check microswitch LS6 Check connector J6
7	Cutter won't work or malfunction	Microswitch malfunctioning Defective motor Defective cutter	Check microswitches LS2 and LS3 Check connectors J8 and J9 Check the motor and capacitor Replace the cutter blade
8	Light source (halogen lamp) won't light	Relay Ry4 malfunctioning Blown fuses Lamp out of place Lamp burned out Broken triac (BCR16C-8R) Defective light control PCB Connector	Check relay Ry4 Check the operation of thyristor (SIRE 3) Replace fuses F5 and F6 (10A) Replace the lamp Replace it Replace it Check connectors CN1, CN2 and CN4
9	Paper not feed	Nip roller free knob out of position Infeed roller won't rotate Paper end caught by feed roller	Turn the nip roller free knob to symbol ⊗ Check the drive chain Check paper end for wrinkles
10	Master quality not satisfactory	Over-or under-exposure Developing temperature	Improper setting of the EXPOSURE dial If the adjustment is impossible replace light control PCB Defective panel heater
11	Partially lost image	Dirty copy glass Dirty mirror Light leakage	Clean the glass Clean the mirror Taping
12	Silver deposit on part of master	Processor conveyor unit rollers dirty Auxiliary exposure isn't made	Clean the rollers Replace the lamp
13	Scratches on part of master	Paper feed rollers of processor unit stained or foreign matter on them Paper guides stained or foreign matter on them	Clean them Clean them

Switchboard

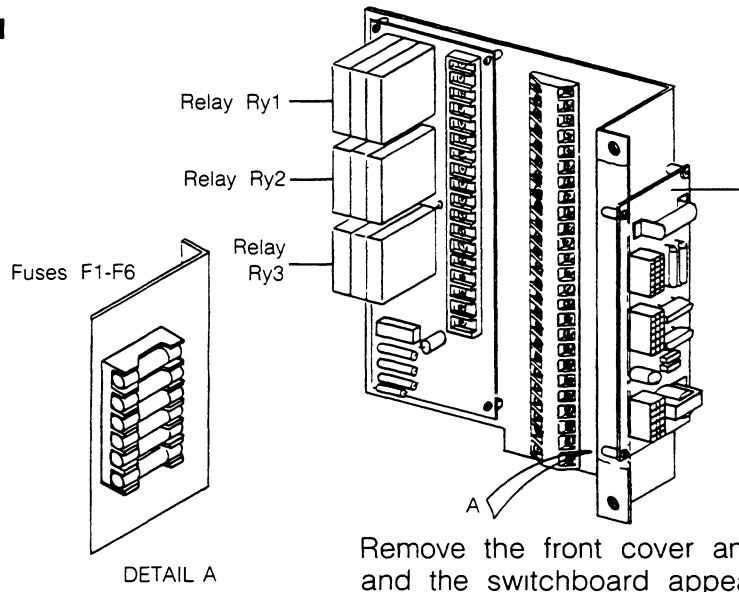

Remove the front cover and switchboard cover, and the switchboard appears

4-6 Wiring Diagram

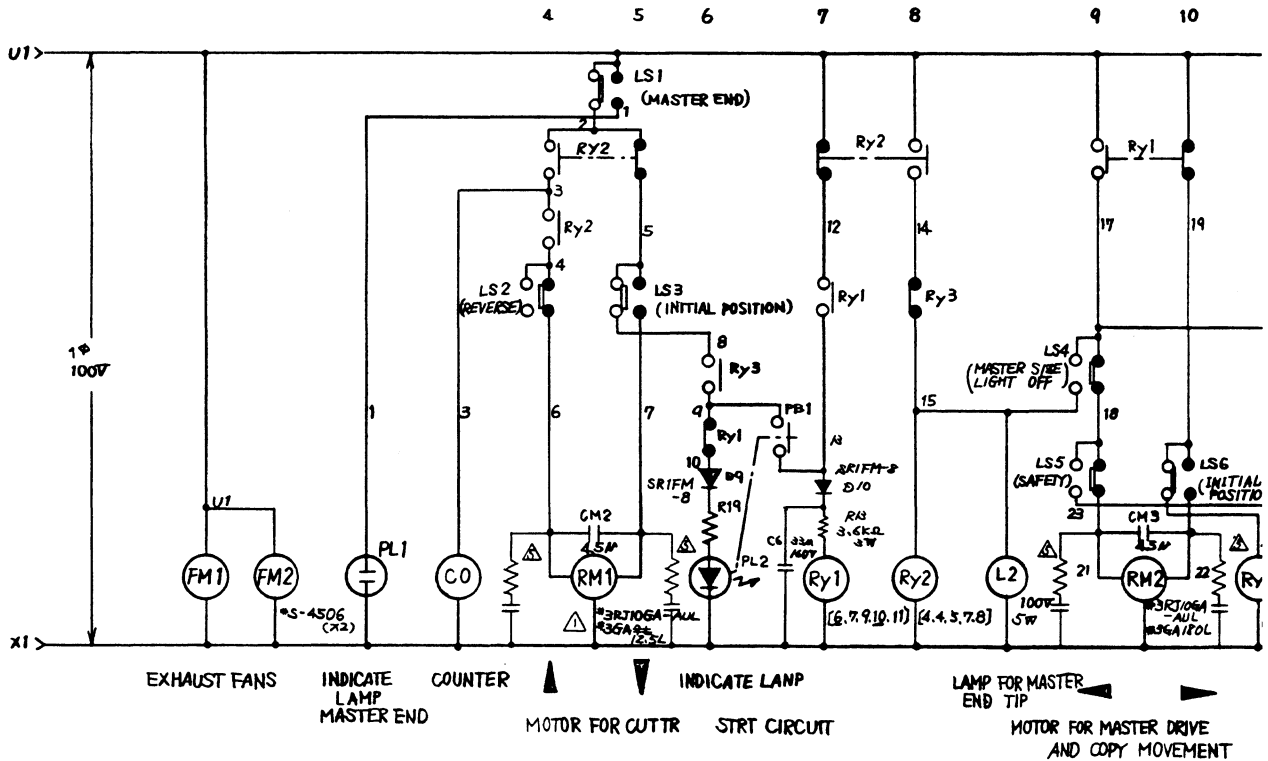
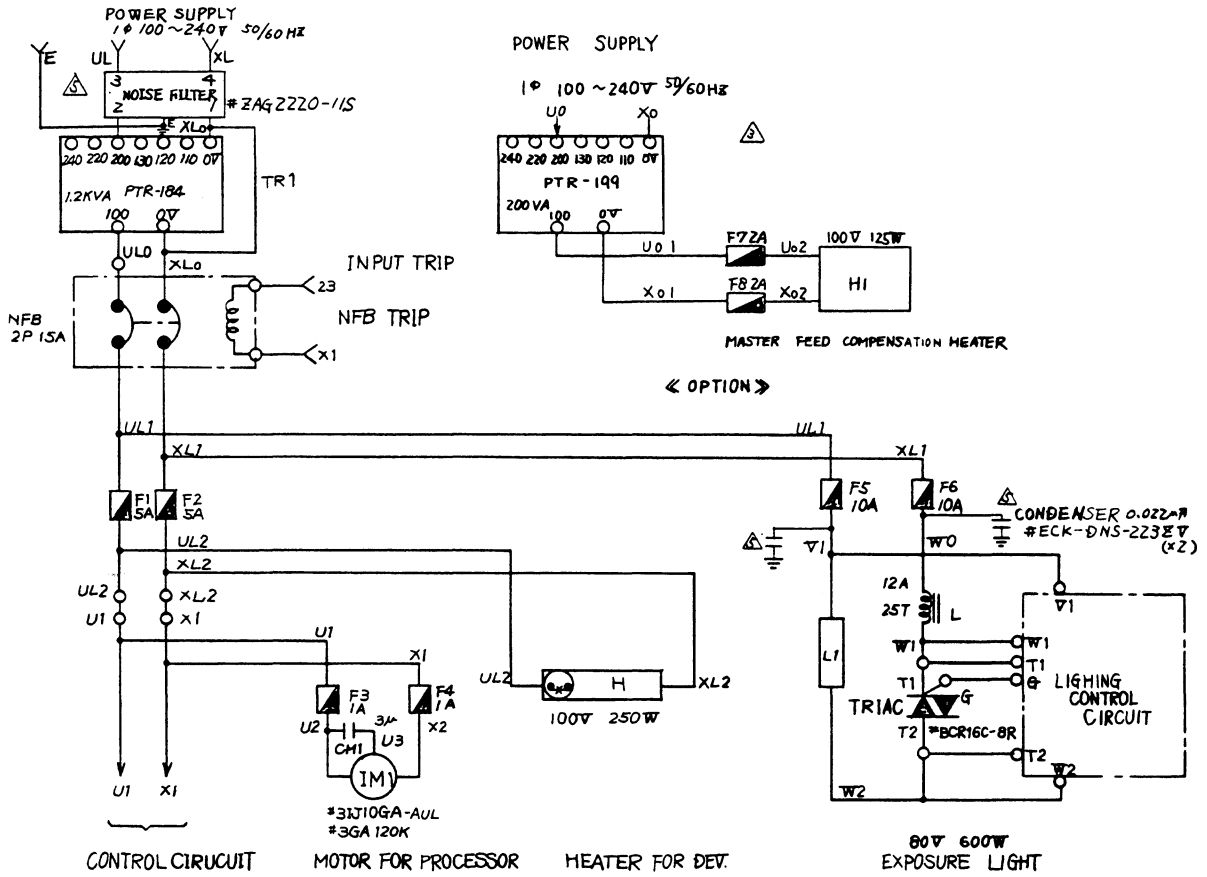

LIGHTING CONTROL CIRCUIT

1

2

3

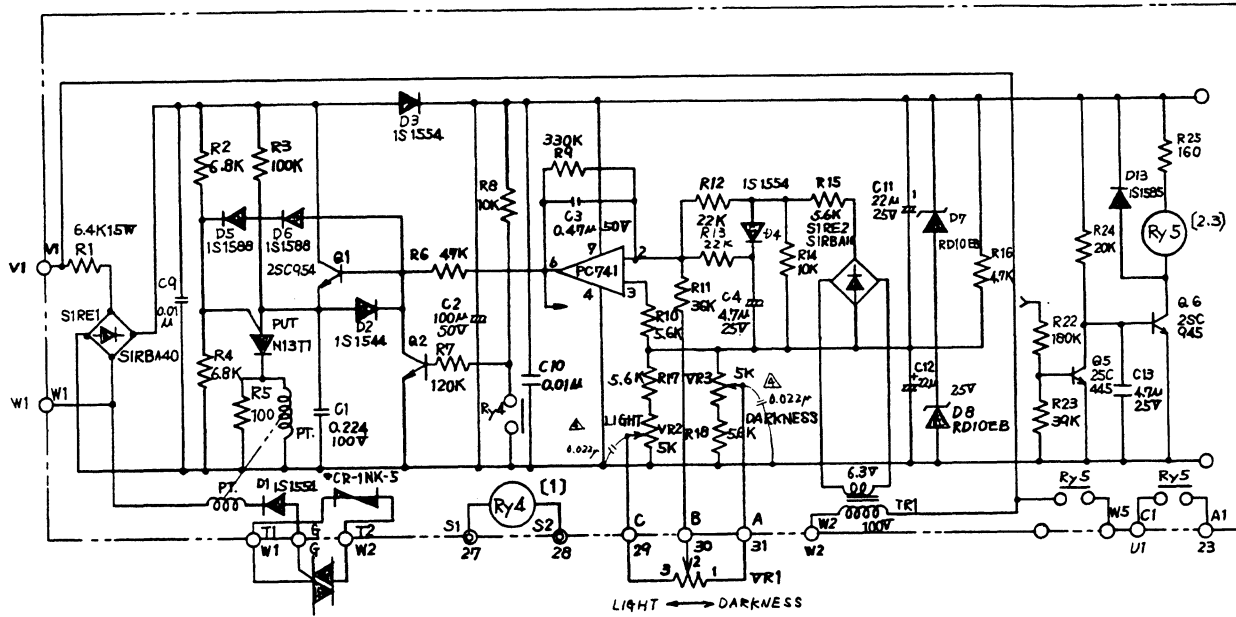

(3)

11

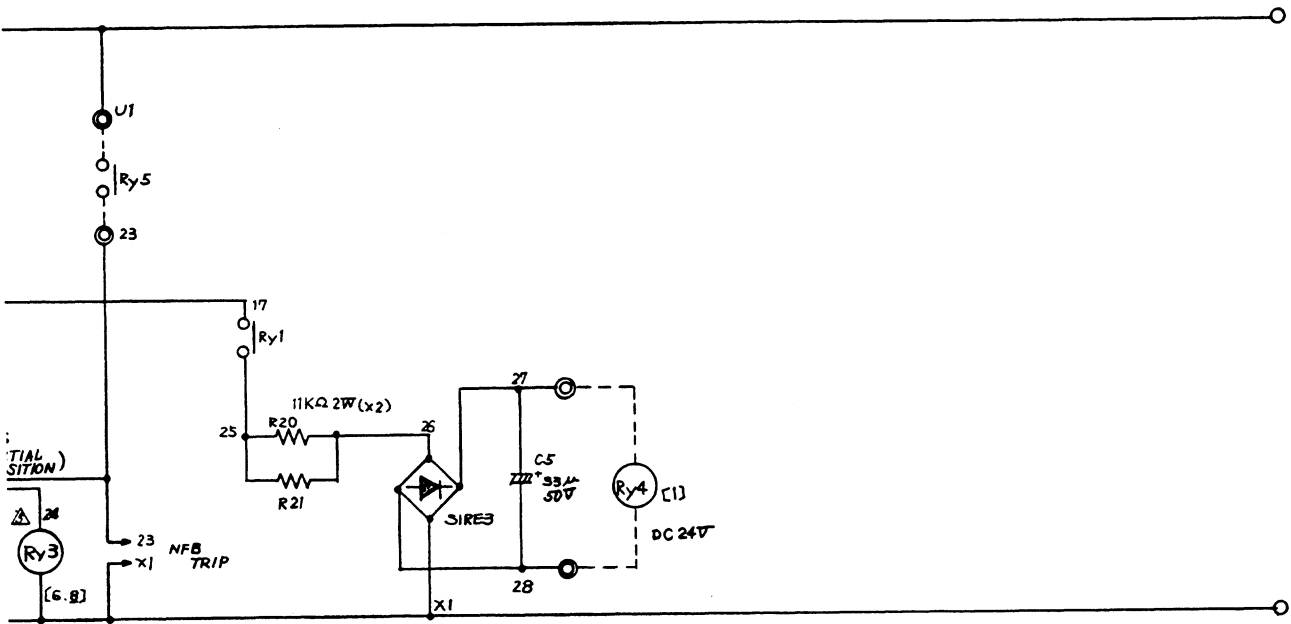

RELAY FOR LIGHT

4-6 Wiring Diagram

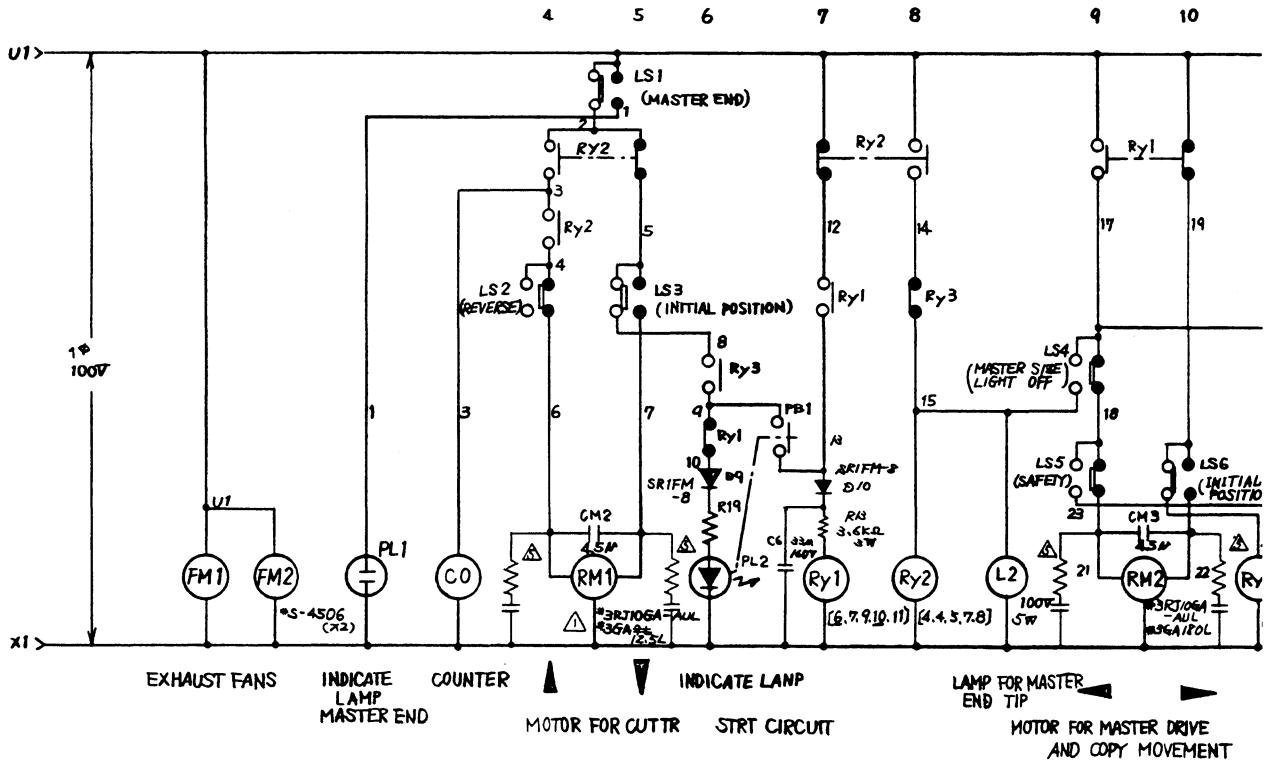
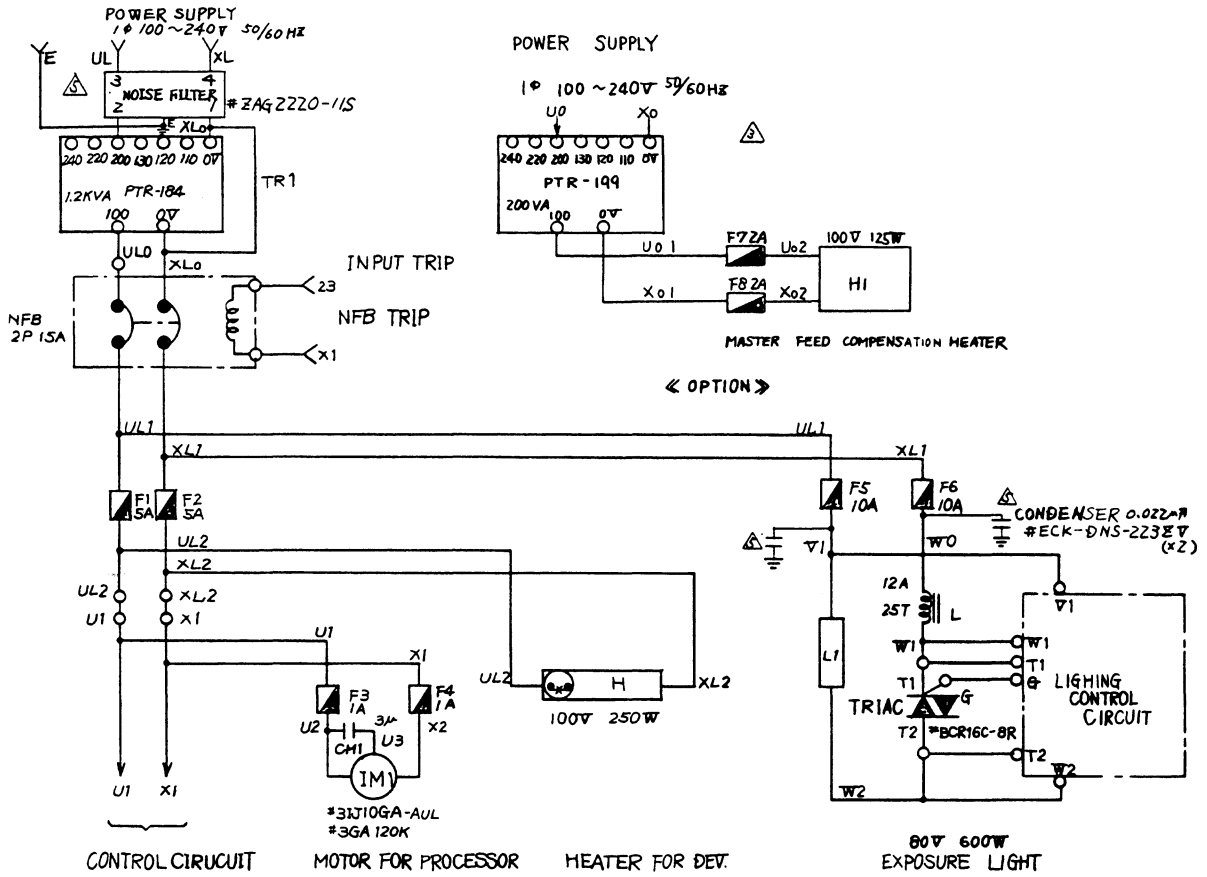

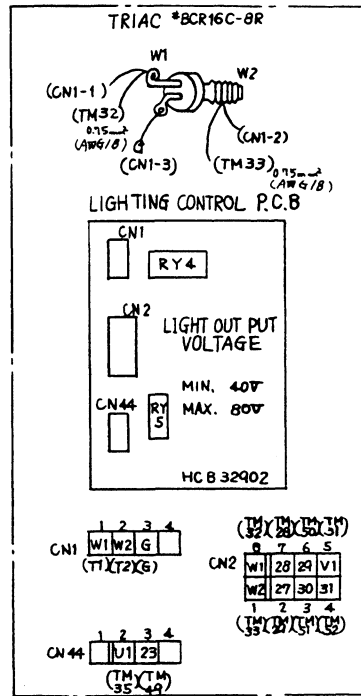
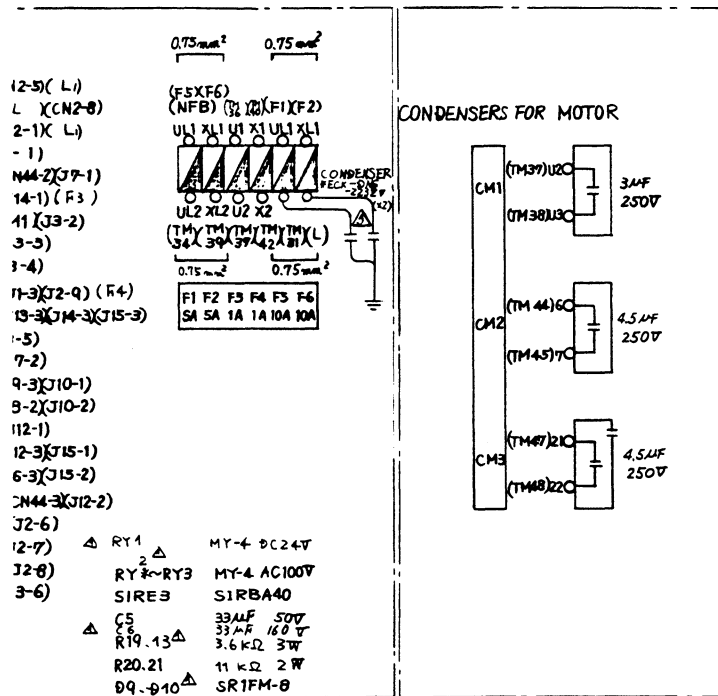
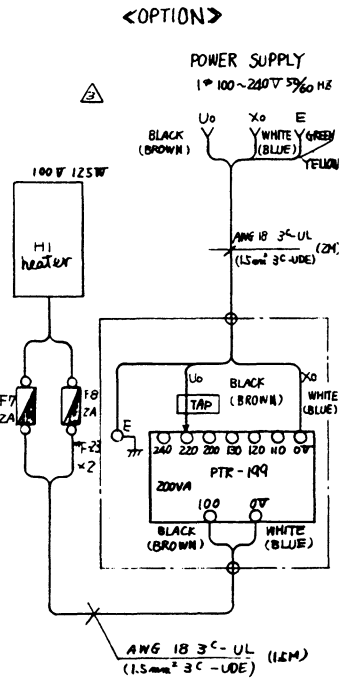
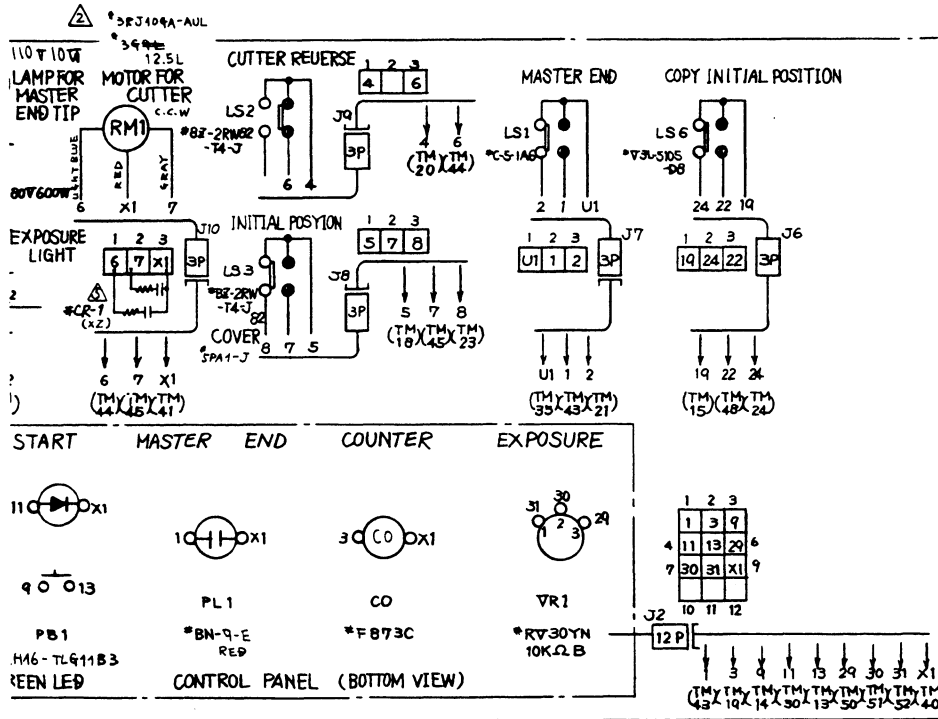

mm.
lion in Site.
with sponge for attaching fuse holder *F1-23.
where it will be readily visible.
heater and fuse holder should be long enough as
attach in distribution board.
re "Uo" of Transformer.
re "ULO" of N.F.B

REFERENCE DIA.
1 WIRING SYSTEM DIA. HCS31575

MITSUBISHI PAPER MILLS LIMITED

Head office: Shin Nisseki Bldg , 7th Floor
No. 4-2, Marunouchi 3 chome, Chiyoda-ku, Tokyo, Japan
Tel. Tokyo(03)3213 3742

Mitsubishi Paper International, Inc
520 Madison Avenue New York N Y 10022 U S.A. Tel 212-980 9644
Mitsubishi Paper GmbH
Kennedydamm 19 4000 Düsseldorf 30 F.R Germany Tel 211 4397 215
