

SILVERMASTER SYSTEM

CP-414S (40371~)

SERVICE MANUAL

DAINIPPON SCREEN MFG. CO. LTD.

Contents

1. INTRODUCTION	1
2. SPECIFICATIONS	2
3. CUTAWAY SIDE VIEW	4
4. INSTALLATION PROCEDURE	5
5. CHECKING AND ADJUSTING THE OPTICAL SYSTEM	12
5.1 Checking the Dimensional Accuracy	14
5.2 Checking the Focus	16
5.3 Checking the Magnification	17
6. REPLACING THE MIRRORS	18
7. EXCHANGING THE THERMAL FUSES	20
7.1 Light source unit	20
7.2 Dryer unit	21
8. REPLACING THE DRIVE BELT	22
9. REPLACING THE ORIGINAL CONTACT MAT	25
10. REPLACING THE COPY POSITIONING SHEET	26
11. REPLACING THE COPY GLASS	28
12. REPLACING THE DEVELOPER BELT	30
13. REPLACING THE HALOGEN LAMP	32
14. PROCESSOR DRYER	34
15. MAINTENANCE	35
15.1 Maintenance Mode	35
15.2 Copy Glass	36
15.3 Lubricating	37
16. TROUBLESHOOTING	38
16.1 Error Messages	38

ELECTRICAL SYSTEM**BLOCK DIAGRAM**

1. INTRODUCTION

This Manual is intended to be used for after-sale service on CP-414S. For operation of the machine and other details, refer to "CP-414S OPERATION MANUAL", "TECHNICAL GUIDE" and other related documents. Bear in mind that the machine structure and specifications are subject to change without notice.

For parts ordering or consultation, let us know the following information, referring to "CP-414S. PARTS LIST"

- model (CP-414S)
- serial number
- reference numbers and descriptions of parts
- required quantities
- date of delivery

* Publication and duplication of this document are prohibited.

2. SPECIFICATIONS

- **Master in use**
1 roll (SLM-RII, SLM-F)
- **Master width (cm)**
22.9 (9"), 25.4 (10"), 27.9 (11"), 30.5 (12"), 31.0 (12 1/5"), 37.0 (14 9/16"), 40.4 (15 7/8"), 41.4 (16 3/10")
- **Master feed length (cm)**
22.5 – 55.0 (settings in 1mm increments)
- **Eff. exposure size (cm)**
40.4 × 54.0
- **Max. exposure size (cm)**
41.4 × 55.0
- **Eff. copy size (cm)**
40.4 × 54.0
- **Max. copy board size (cm)**
49.5 × 60.0
- **Lens**
Fixed aperture, focal length = 210mm, f-number: 1:13.5
- **Magnification**
100% (fixed at actual size)
- **Exposure method**
Movable copy and master slit exposure system
- **Copy mounting**
Copy facing down, with 180mm pin bar
- **Multiple exposure**
Automatic two-image exposure, multiple exposure
- **Cutter**
Slide cutting system
- **Exposure adjustment**
Digital illuminance adjustment 0 ~ 99
- **Light source**
Halogen lamp, 80V 800W × 1
- **Control panel**
Flat panel, interactive input
- **Master joint detection**
Display message, alarm buzzer, automatic over cutting
- **Dehumidifier**
Heater type
- **Processor unit capacity**
Developer 7 liters, stabilizer 6 liters
- **Replenisher solution amount**
Developer 1 liter, stabilizer 1 liter
- **Initial plate time**
1min 58sec (at 450mm feed)/60Hz
- **Cycle time**
52sec (at 450mm feed)/60Hz

-
- **Copy feed speed**
19.0mm/sec/60Hz
 - **Processor unit feed speed**
12.0mm/sec/60Hz
 - **Solution temp. control**
350W panel heater (with safety thermostat), $29 \pm 3^{\circ}\text{C}$, heater OFF during exposure
 - **Dryer**
400W fin heater
2-stage thermal control (HIGH, LOW) selectable
 - **Safety interlock**
Meets safety standards
 - **Power supply**
AC 100V/110V/120V 1.5kW (USA)
AC 200V/220V/240V 1.5kW (EUROPE)
 - **Machine dimensions (W x D x H)**
100 x 69.5 x 79cm (body only)
100 x 69.5 x 103cm (with legs)
 - **Weight (without solutions)**
135kg
 - **Options**
Replenisher unit

3. CUTAWAY SIDE VIEW

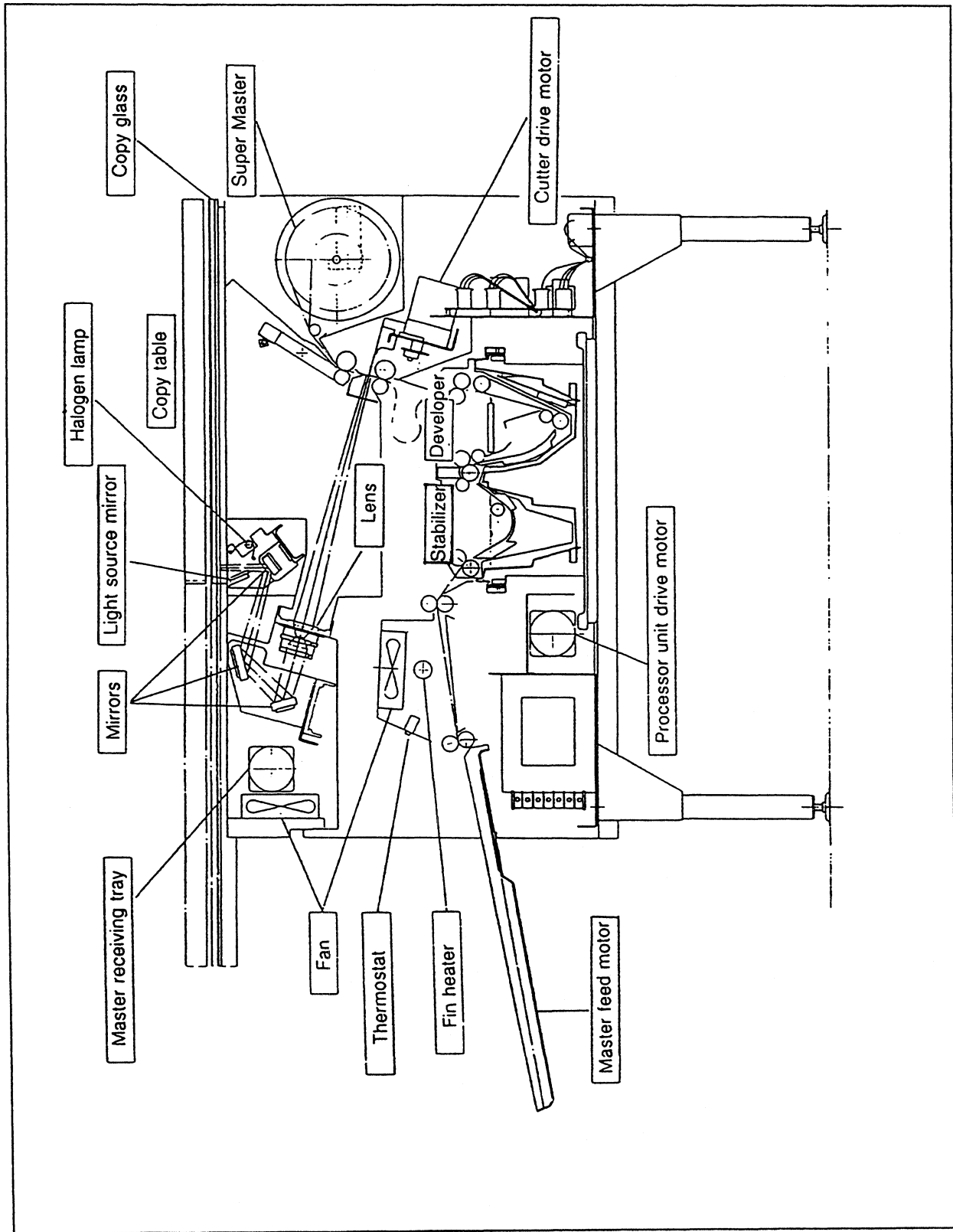

4. INSTALLATION PROCEDURE

Siting Conditions

- Make sure that the installation site is well ventilated throughout the whole year, and that constant temperature (within the range 10°C – 30°C) and humidity (within the range 40% – 70%) are maintained.
- Avoid siting in the direct sunlight.
- The power supply used is single-phase AC 100V/110V/120V 1.5kW (USA), AC 200V/220V/240V 1.5kW (EUROPE). Connect to an outlet of 15A or above and keep voltage fluctuations to within $\pm 10\%$.
- Abide by safety standards and ground the body.
- Maintain a service access area at the rear of the machine of 40cm or more.
- The machine weighs 135kg. Install on a flat surface that can sufficiently withstand that weight.
- Avoid installing in sites subject to vibration.

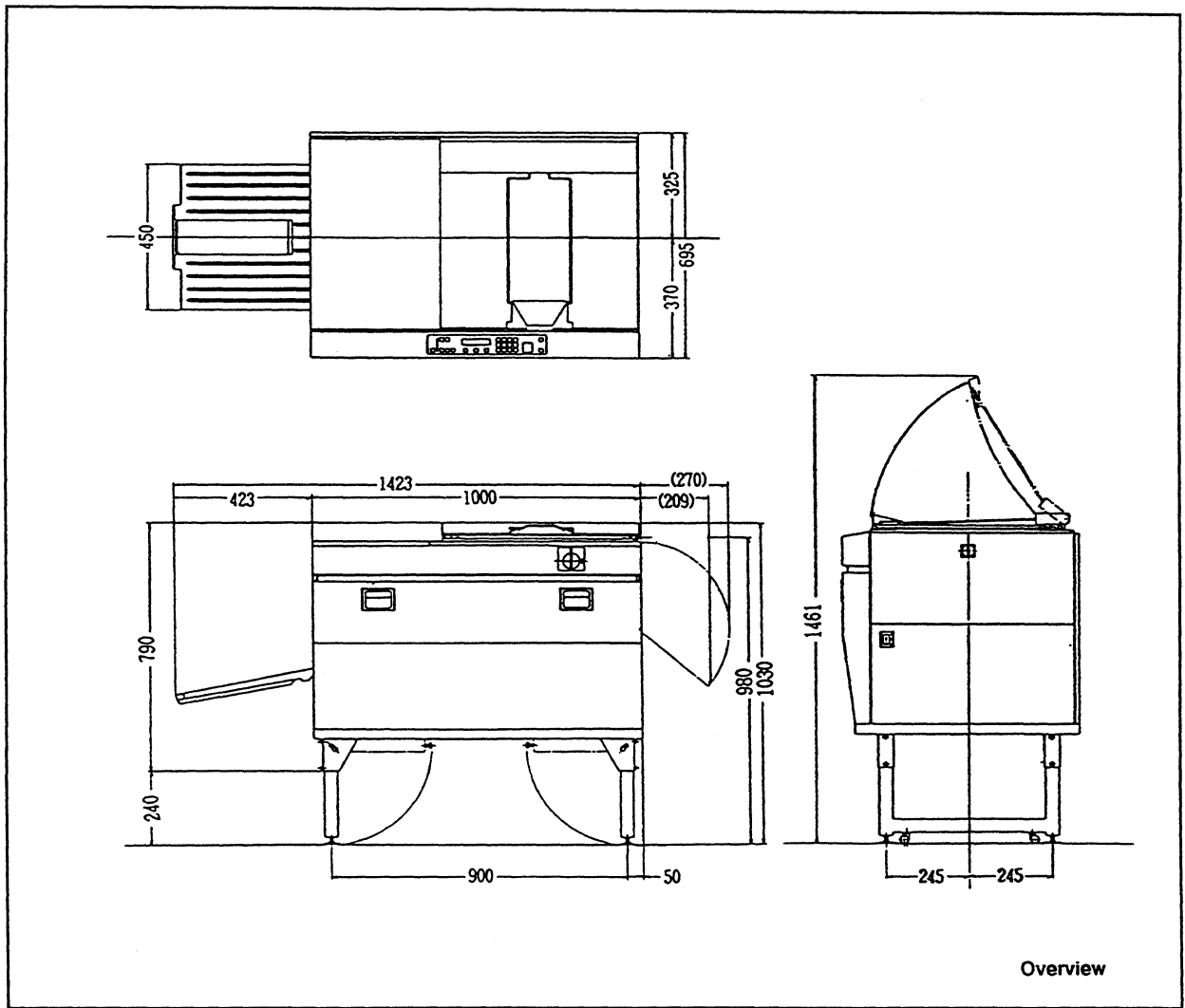

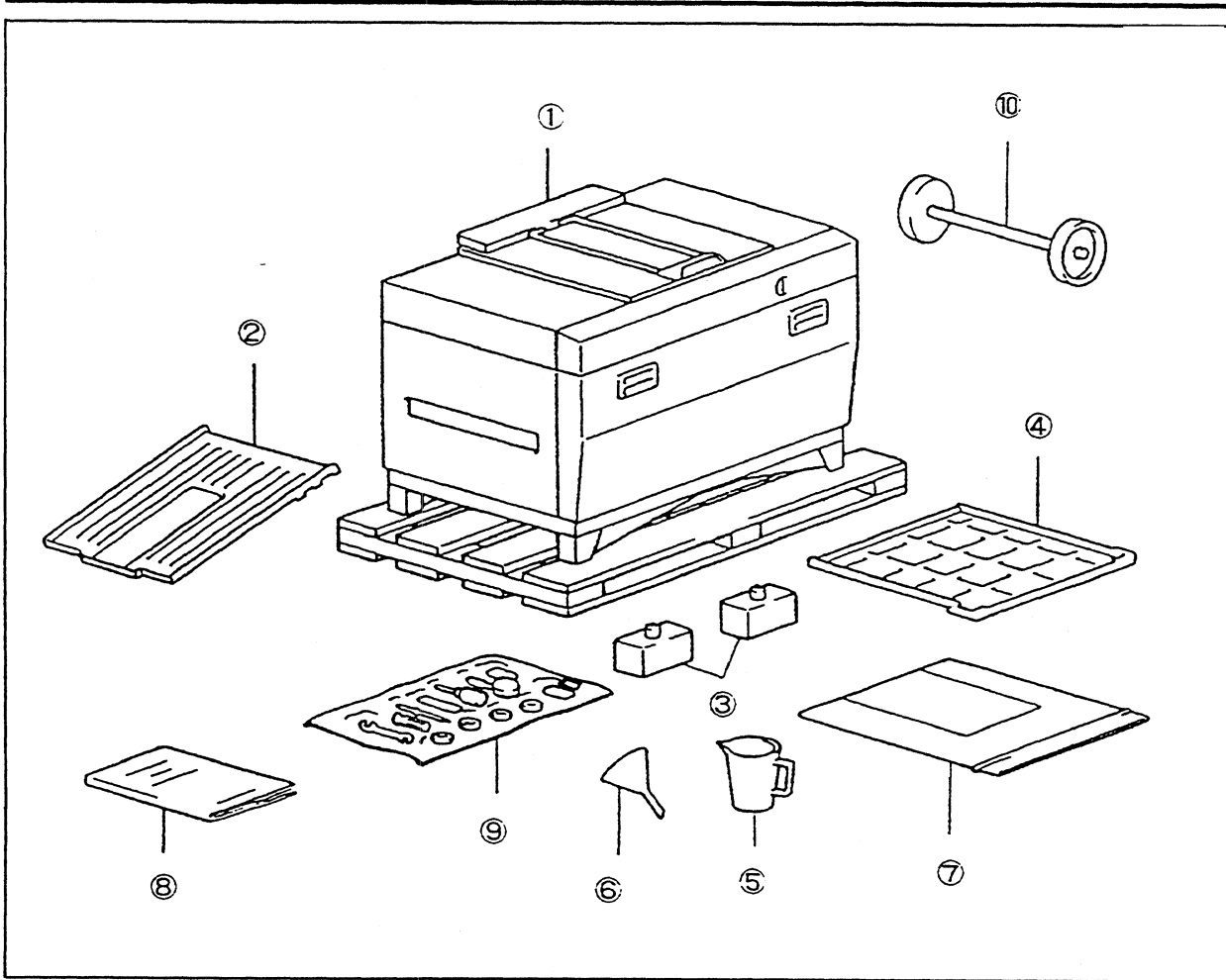

Packaging List

Be sure to check the following list when unpacking.

	Name	Q'ty
1	Body	1
2	Master discharge tray	1
3	Replenishing bottle	2
4	Drip vat	1
5	Measuring cup	1
6	Funnel	1
7	Test chart, photographic samples	1 set
8	Instruction Manual	1
9	Spare parts	1 set
10	Spools × 2, spool shaft	1 set

Spare Parts List

	Name	Q'ty
1	Screwdriver set	1 set
2	Leg bases	4
3	Spanner	1
4	Cutter knife	1
5	Oil can	1
6	Blower brush	1
7	Glass fuses 10A 250V 1A 250V, 2A 250V, 5A 250V, 12A 250V, 3A 250V	2 each
8	Thermal fuses For dryer (w/ round tip) For light source (w/ connector)	1 each
9	Fixed bolts Hexagonal bolts (M6 × 20) Spring lock washers M6 Plain washers M6 (19)	4 each
10	Screws, bolts, etc.	1 set

Installation

[Procedure]

1. Remove the packaging around the body of the machine.
2. The pallet is attached to the body by transportation fixtures.
Loosen the securing bolts to the left and right of the body.
3. The legs are secured by nylon bands. Cut the bands.
4. Lift one end of the body up from the pallet and attach the legs.
(This work should be carried out by 2 or more workers.)
5. Attach the legs to the other side following the same procedure as above.
6. Carry the machine to the installation site and place on the leg bases. (This work should be carried out by 3 or 4 workers.)

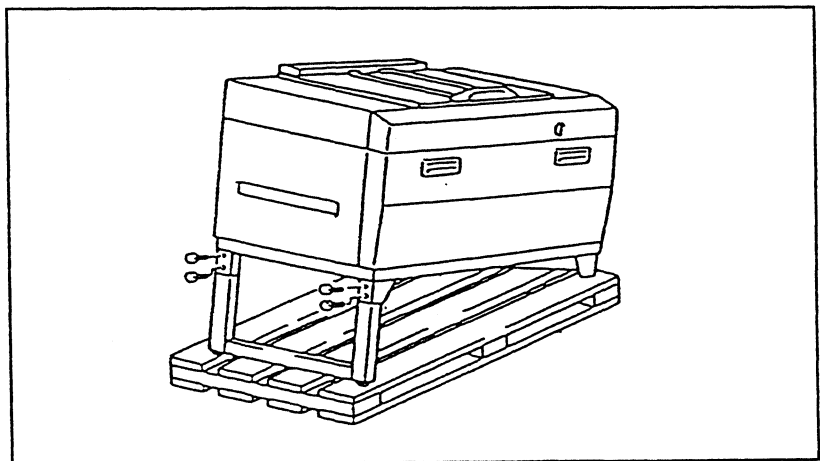

-
7. Place a clean sheet of paper on the copy glass and place a level on top. Adjust the adjusting bolts so that the body is completely level.
 8. Remove the front cover and remove the processor unit.
 9. Remove the transfer unit and clean the developing and fixing tanks.
 10. Replace the processor body and place the drip vat under the body.
 11. Install the cutter blade.

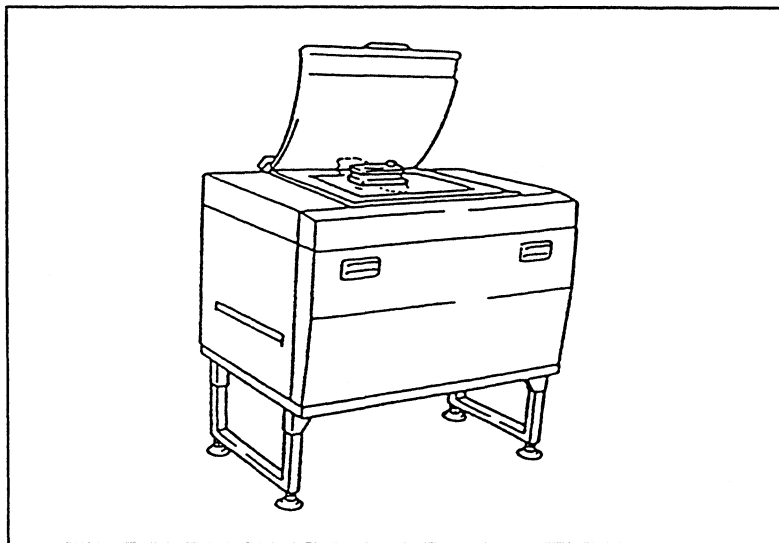

Preparing Solutions

1. Mix the developer and stabilizer according to the details given in the Instruction Manual. Pour the solutions into the tanks and replenisher bottles.
2. Place the replenisher bottles containing the prepared solutions at each unit.

Connecting the Power Supply

1. Check that the POWER switch is set to OFF.
2. Connect the input leads.

Inspections and Adjustments

- The CPU board can be seen to the right when the front cover of the body is removed. Adjustments are made by the DIP switches on the CPU board.

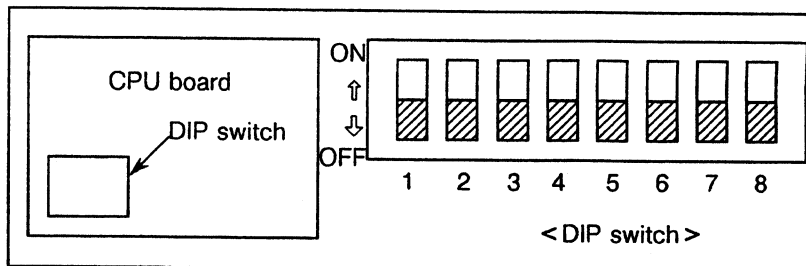

• DIP Switch Settings

No.	Item	Use	Normal Setting
1	Data input	Used with DIP SW5 for inputting the master feed amount compensation coefficient.	OFF
2	Frequency selection	Selects between 50Hz and 60Hz. ON: 50Hz, OFF: 60Hz.	ON/OFF
3	Inch/millimeter selection	Selects the unit system for feeding the master. ON: inch, OFF: millimeter	ON/OFF
4	Repeated running	For repeated running of a series of operations Start by <input type="checkbox"/> key, stop by <input checked="" type="checkbox"/> key.	OFF
5	Data display	Used to display presently input basic data.	OFF
6	English/Japanese selection	Selects display format. ON: English, OFF: Japanese	ON/OFF
7	Replenisher unit	Used when replenisher unit (option) is attached.	OFF
8	Initial reset	Used with DIP SW1 and system is initialized (reset to 1.000) when the power is turned ON after having turned DIP SW1 and SW8 ON.	OFF

- Select the frequency so that it matches the local frequency.
50Hz: set DIP switch 2 to ON.
60Hz: set DIP switch 2 to OFF.

-
3. Select the system of measurement (inch or millimeter)
Inch: set DIP SW3 to ON.
Millimeter: set DIP SW3 to OFF.
 4. Turn the power switch ON.
 5. Set the master plate in place as instructed in the Instruction Manual.
 6. Check and adjust the master feed length.
 - 1) Set the length of master that is most frequently used. (e.g. 480mm)
 - 2) Press the start switch and measure the length of the exposed plate. (e.g. 490mm)
 - 3) Set DIP SW1 and SW5 on the CPU board to ON. Input the actual value (490mm) by using the number keys and press the dehumidifier  key.
 - 4) Set DIP SW1 and SW5 to OFF.
 - 5) Check the compensation coefficient. The compensation coefficient will be displayed on the control panel display by setting DIP SW5 to ON.
 7. Carry out final assembly and checks.
 - 1) Attach the covers.
 - 2) Check the series of operations as described in the Instruction Manual.
 - 3) Carry out a test exposure using the test chart.
 - 4) Check the distance between diagonally opposite corners.
 8. Check and adjust the distance between diagonally opposite corners.

This adjustment is conducted thoroughly before shipment. However, if one of the the distances between diagonally opposite corners is greater, check and make adjustments following the procedure below.

[Procedure]

1. Place a suitable original such a test chart (drawn with grid lines) or a scale on the copy glass.
2. Expose and measure the distance E and F between diagonally opposite corners.
The tolerance is within 0.5mm.

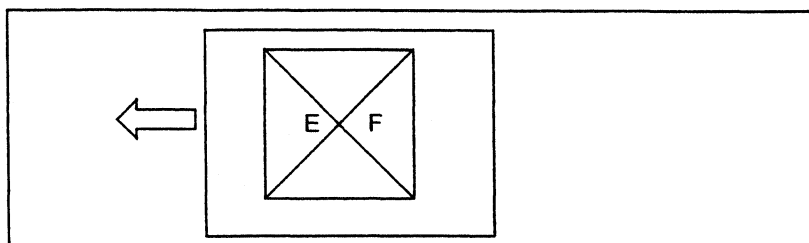

If E is greater than F:

- Either lower adjusting bolt ① at the base of the body, or raise adjusting bolt ②.

If F is less than E:

- Either raise adjusting bolt ① at the base of the body, or lower adjusting bolt ②.

▶ *The height of the body can be increased or decreased by about 1mm by one full turn of the adjusting bolt.*

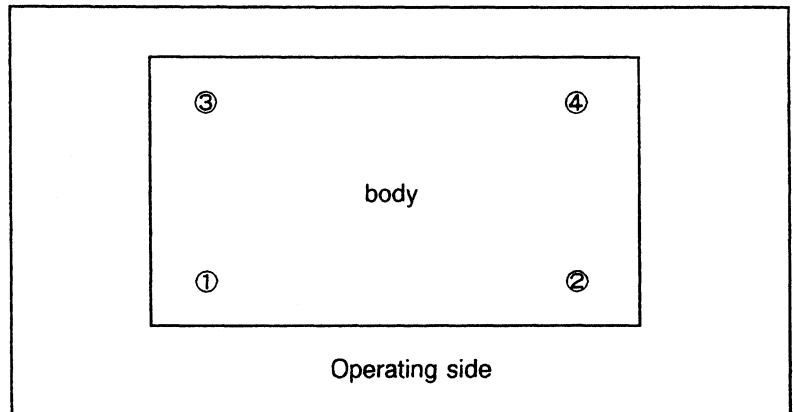

5. CHECKING AND ADJUSTING THE OPTICAL SYSTEM

The focus and magnification are set prior to shipment. However, if they are considered as faulty, adjust them following the procedure below.

Check and adjustment procedure

1. To adjust the dimensional accuracy:
Move mirrors ② and ③ in the optical system to the left and right.
2. To adjust the focus:
Move mirrors ② and ③ in the optical system to the left and right.
3. To adjust the magnification:
Move the lens to the left and right.

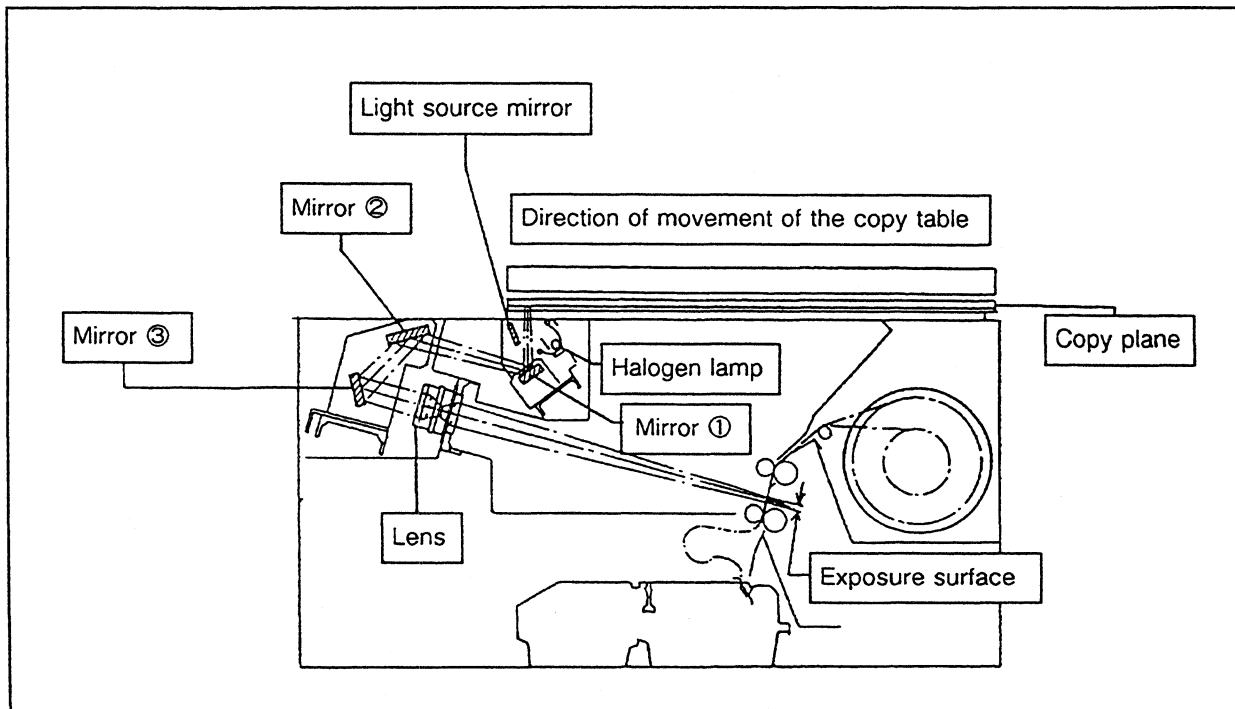

$$\text{Distance between copy plane (C) and lens (L): } A = f \left(1 + \frac{1}{m} \right)$$

$$\text{Distance between lens (L) and exposure surface (P): } B = f (1 + m)$$

where,

f : focal distance of lens

m: magnification

<Correct Focus >

The theoretical positional relationship between the copy plane, lens and exposure surface is as follows:

$$A = B \quad (\text{ex}) \quad f: 210 \text{ mm} \quad m: 1 (100\%)$$

$$f \left(1 + \frac{1}{m}\right) = f (1 + m)$$

$$210 \times \left(1 + \frac{1}{1}\right) = 210 (1 + 1)$$

$$\therefore A = B = 420$$

In actual fact, value f differs according to the lens and is not always 420mm.

5.1 Checking the Dimensional Accuracy

- Mount a test chart (one drawn with a grid) or an original such as a scale suitable for checking the dimensional accuracy and magnification.
- Make an exposure with the master feed length set at about 550mm, and check the dimensional difference between A, B, C, D and a, b, c, d.

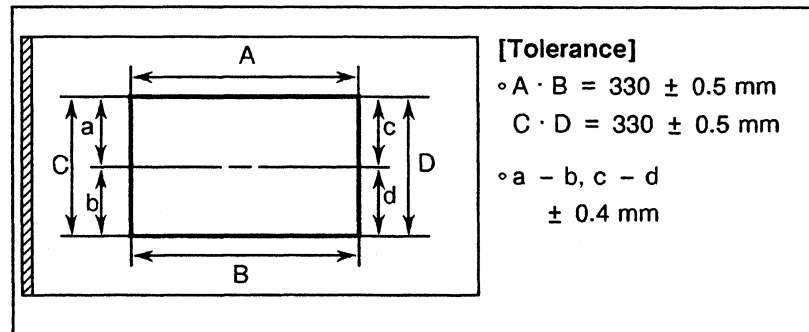

- ▶ Dimensions A and B in the feed length direction are maintained mechanically and cannot be adjusted.
- ▶ Owing to the characteristics of the slit exposure system of the CP-414S, measure a, b, c, d after measuring dimensions C and D.

Adjustment Procedure

→ Move optical system mirrors ② and ③ to the left and right and adjust.

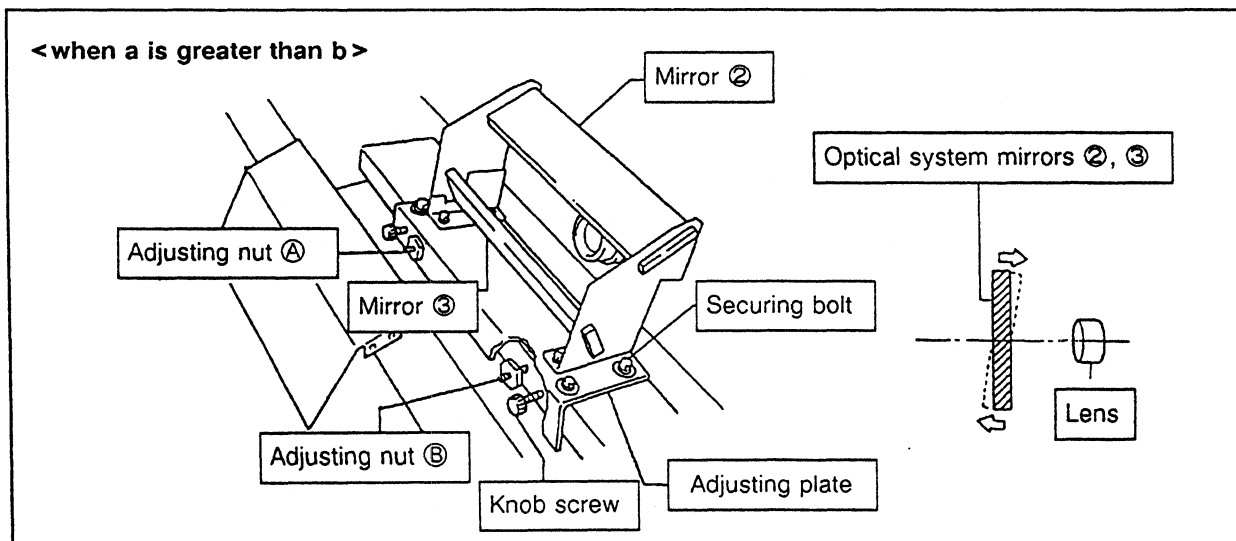

-
1. Loosen the securing bolt of the adjusting plate.
 2. Loosen the two knob screws.
 3. Check in which direction optical system mirrors ① and ③ should be moved. (See focus adjustment procedure.)
 4. Turn adjusting nut ① clockwise, and adjust adjusting nut ② counterclockwise.
 - ▶ *For positional repeatability, mark the top of the hexagonal nut and move by the same amount.*

< Guideline for Adjustment >

Adjustment is made for about 0.5mm for each full turn of the adjusting nut.

5. Tighten the knob screw.
6. Lock the securing bolt and check exposure.
7. Readjust if the dimensions are outside the tolerance.

5.2 Checking the Focus

- Expose the test chart (resolution chart) increasing the correct exposure in two steps.
- The focus is correct if a resolution of more than 10 steps is obtained. Adjust the focus if 10 steps cannot be obtained.

Adjustment Procedure

→ Move optical system mirrors ② and ③ the left and right and adjust.

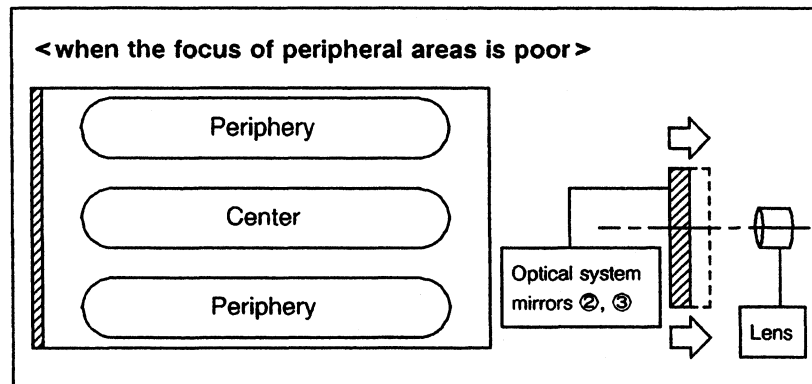

▶ For positional repeatability, mark the top of the adjusting hexagonal nut before moving.

1. Loosen the securing bolt of the adjusting plate.
2. Loosen the two knob screws.
3. Rotate the adjusting nuts clockwise to bring the optical mirrors ② and ③ closer to the lens.
4. Tighten the knob screws.
5. Lock the securing bolt and check exposure.
6. Readjust if the dimensions are outside the tolerance.

5.3 Checking the Magnification

5.3.1 Checking the dimensional accuracy

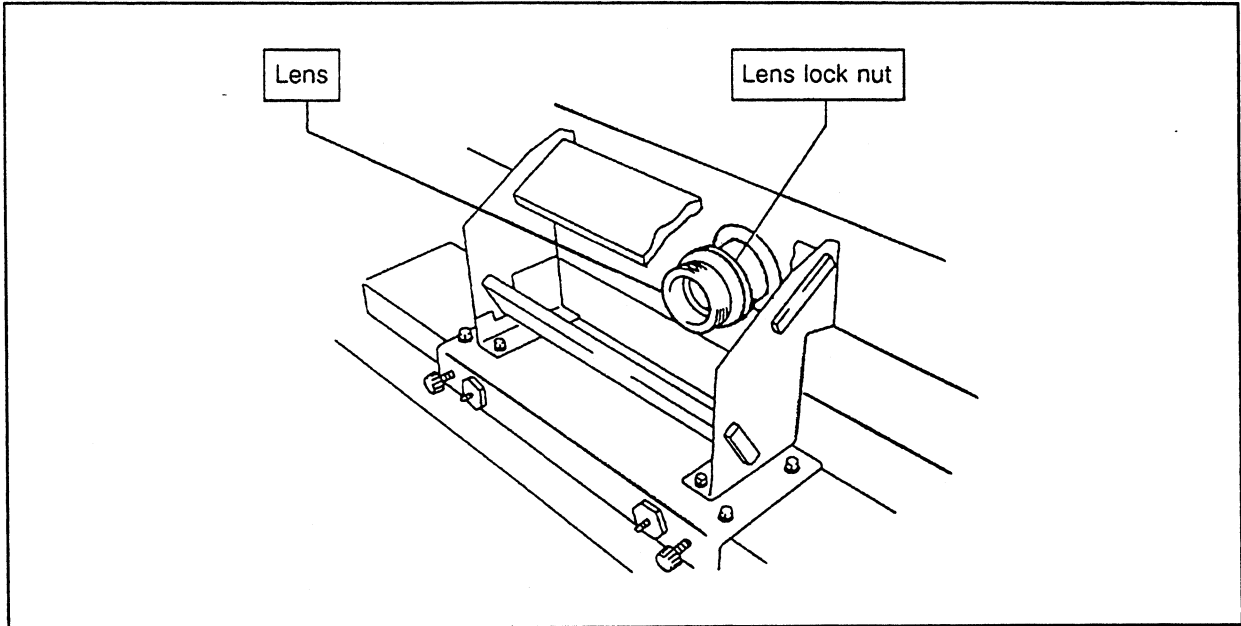

Adjustment Procedure

→ Move the lens in the optical system to the left and right and adjust.

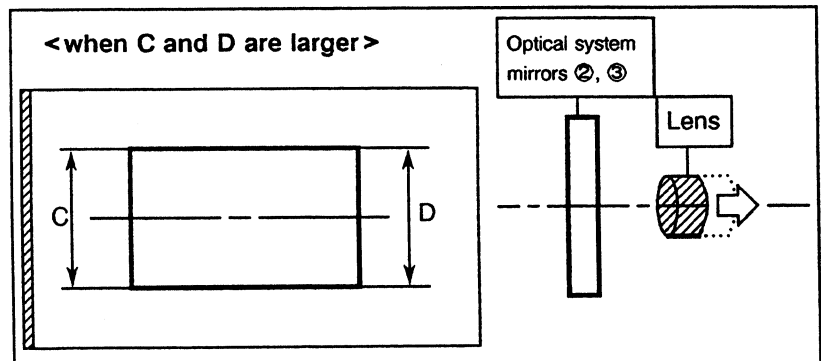

▶ Before adjusting the magnification, check the dimensions up to the tip of the lens and the lock nut to maintain dimensional repeatability.

1. Holding the lens so that it does not rotate, rotate the lens lock nut counterclockwise and loosen.
2. Rotate the lens clockwise (so that it moves away from the mirror), and tighten the lock nut.
3. Make an exposure and check dimensions C and D.

<Guideline for Adjustment >

Adjustment is made for about 1.0mm for each full turn of the lens.

6. REPLACING THE MIRRORS

Replace the lens if it is scratched. Scratches in the lens adversely effect image quality.

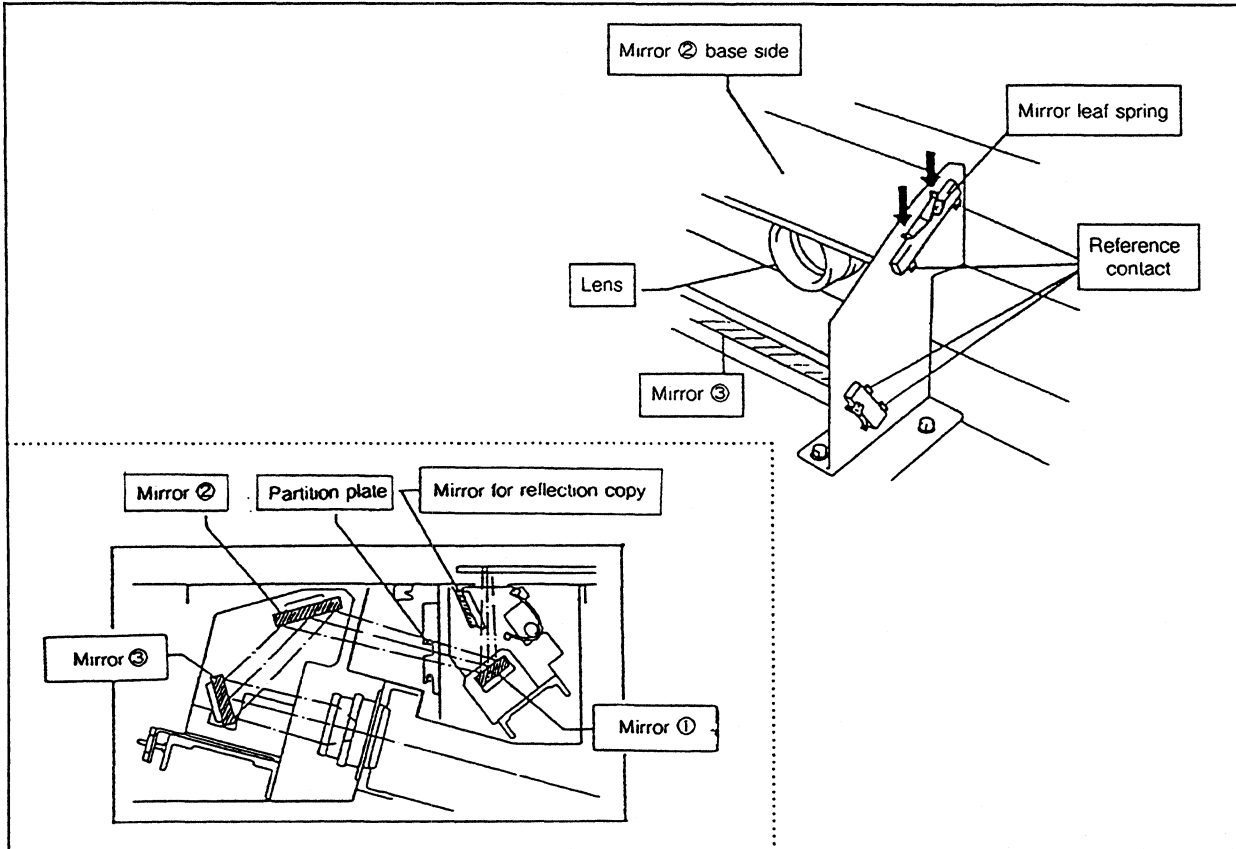

- ▶ At the installation section of the optical system mirrors, three reference contacts (two at the mirror reflection surface side, and one at the opposite side) are installed so as to prevent the mirrors from twisting.

[How to Remove]

1. Turn the POWER switch OFF.
2. Remove the top left cover of the body.
3. Cover the lens with the lens cap to protect the lens.
4. Press the mirror leaf spring in the direction of the arrow, and remove the mirror leaf spring. (The mirror becomes out of position when shifted towards the outside.)
5. Remove the mirror.
 - ▶ *Mirror ① can be easily removed if the partition plate is removed.*
 - ▶ *A leaf spring is installed at the reflection surface side of the mirror for reflection copy.*

[How to Install]

1. Install a new mirror.
 - ▶ *Take care not to dirty or scratch the mirror.*
 - ▶ *Check that the leaf spring is working effectively.*
2. Install in reverse order.
3. Make an exposure, and check the focus and magnification.

7. EXCHANGING THE THERMAL FUSES

7.1 Light source unit

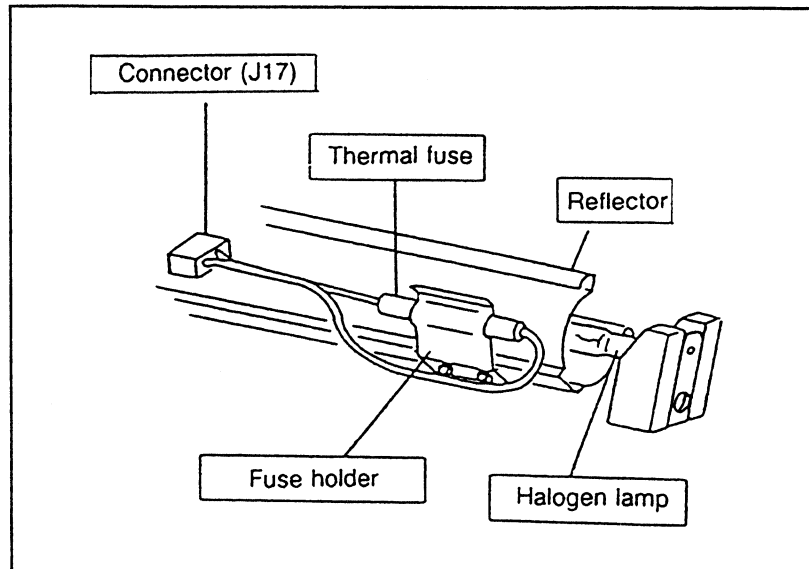

[How to Remove]

1. Move the copy table to the left.
To move the copy table, press  and **2** when in STANDBY mode.
2. Turn the power switch off.
3. Remove the upper right cover on the main unit.
4. Remove the fuse connector (J17).
5. Remove the fuse from the fuse holder

[How to Install]

1. Attach a new fuse.
2. Reverse the removal procedures to reassemble the unit.
3. Turn power back on.
4. Press  and **4** to move the copy table to the right when in STANDBY mode.

7.2 Dryer unit

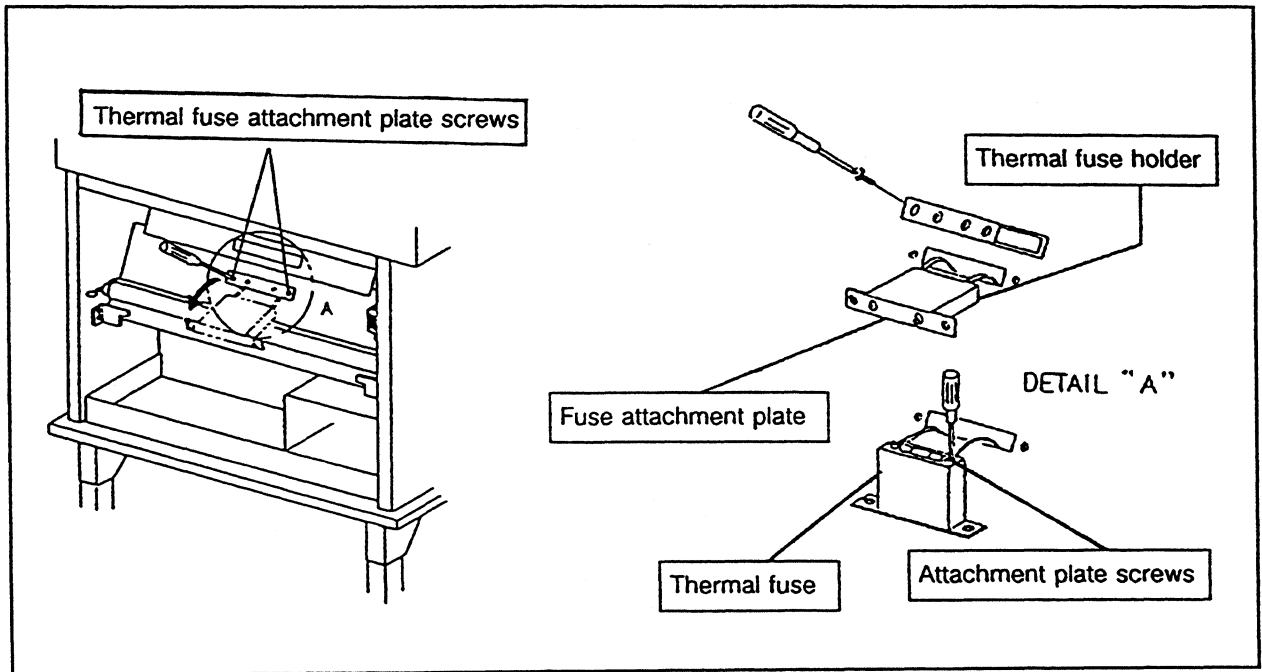

[How to Remove]

1. Turn the power off.
2. Remove the front and left side covers from the main unit.
3. Remove the screws on the attachment plate for the fuse.
4. Pull the fuse holder out in the direction of the arrows.
5. Loosen the fuse screws and remove the old fuse.

[How to Install]

1. Attach a new fuse.
2. Reverse the removal procedures to reassemble the unit.

8. REPLACING THE DRIVE BELT

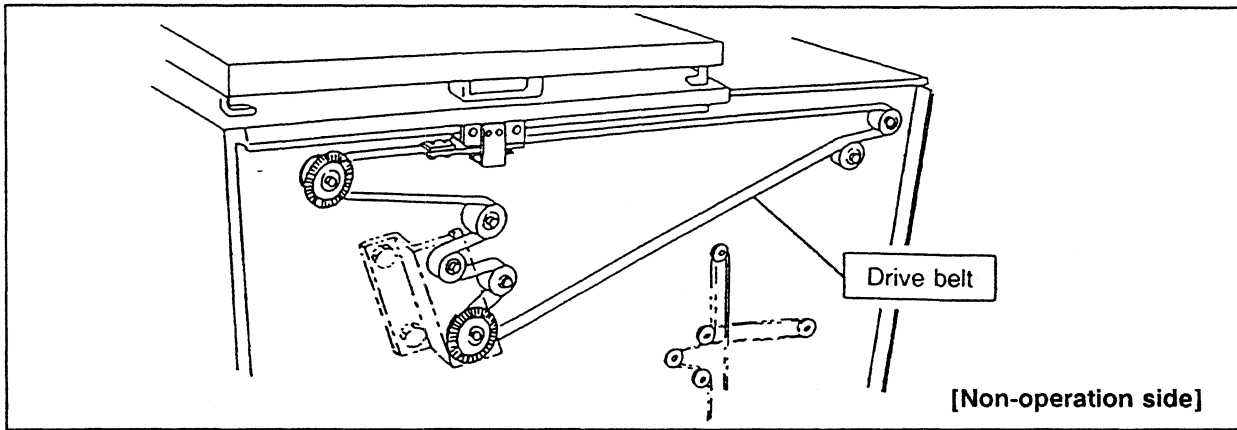

[How to Remove]

1. Set the roller up/down knob to free (δ).
2. Set the START key to ON, move the copy section to the discharge side and set the POWER switch to OFF.
3. Remove the rear cover.
4. Remove the belt tensioner fixing bolt and the tension bolt.
5. Remove the securing side belt retainer and the securing bolts from the belt retainer.
6. Remove the drive belt from the pulleys.

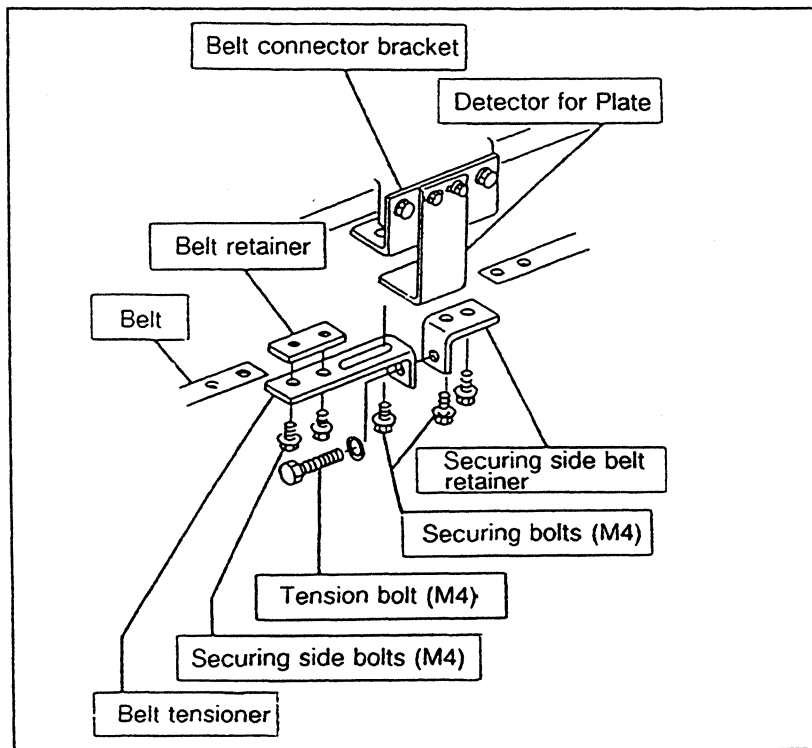

[How to Install]

1. Install a new belt on the belt connector bracket following the removal procedure in reverse.
 - ▶ *Do this with the copy section left as it is on the discharge side.*
 - ▶ *Place the drive belt in position in the center of the pulleys.*
 - ▶ *Install the end of the drive belt so that it is parallel to the belt retainer, belt tensioner and the end of the securing side belt retainer.*
 - ▶ *Leave the belt tensioner fixing bolt temporarily fastened.*
2. Turn the POWER switch ON, and tighten the tensioner bolt until the copy section begins to move.
 - ▶ *Tighten the tensioner bolt two more turns past the position where the copy section began to move.*
3. Fasten the belt tension fixing bolt.
 - ▶ *If the tension is uneven, loosen the belt retainer fixing bolt and fasten it again.*

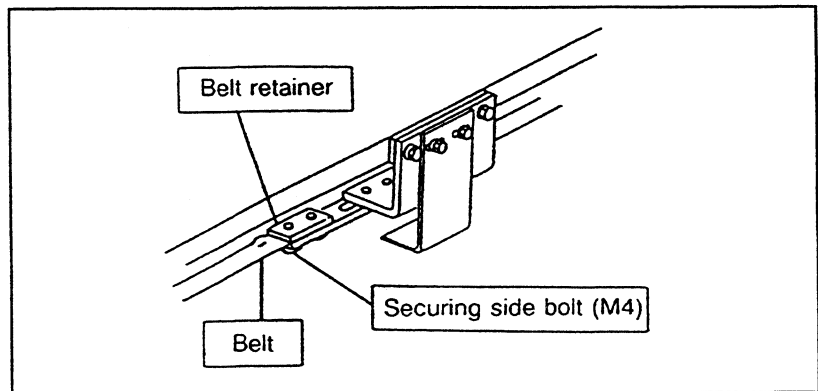

After replacing the drive belt, rotate it a few times. If snaking occurs, adjust the belt according to the following procedure.

[Snaking adjustment procedure]

— When the snaking is on the detection plate side —

1. Move the copy section to the discharge side (to the position where the master side upper cover can be removed).
2. Slightly loosen the belt tension.
3. Remove the master side upper cover.
4. Loosen the four idler pulley shaft fixing bolts.

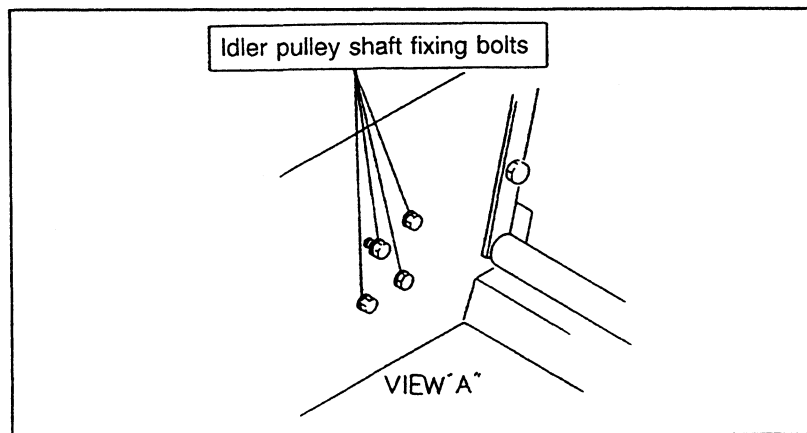

5. Insert spacers (0.05 - 0.1 mm) between the main unit side plate and the idler pulley shafts.

▶ *The spacers should be the same size and inserted in the same direction.*

6. Tighten the fixing bolts.
7. Tighten the tensioner bolt.

▶ *Refer to HOW TO INSTALL.*

8. Drive the belt and confirm that it does not snake.

▶ *If it does, repeat the above adjustment procedure with smaller or larger spacers.*

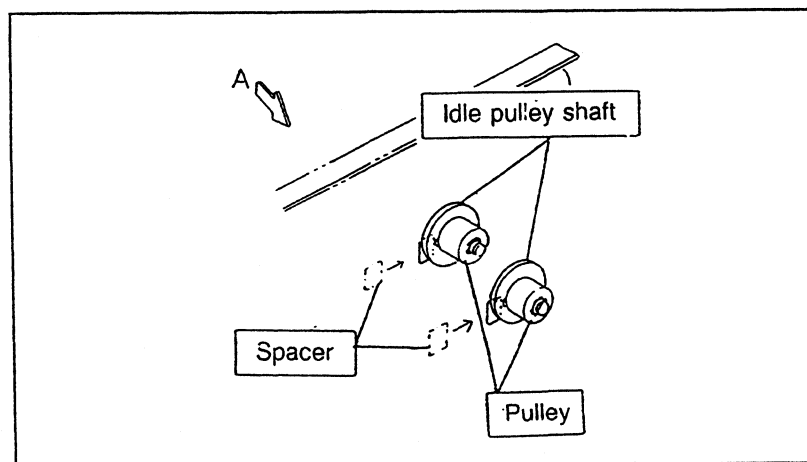

9. REPLACING THE ORIGINAL CONTACT MAT

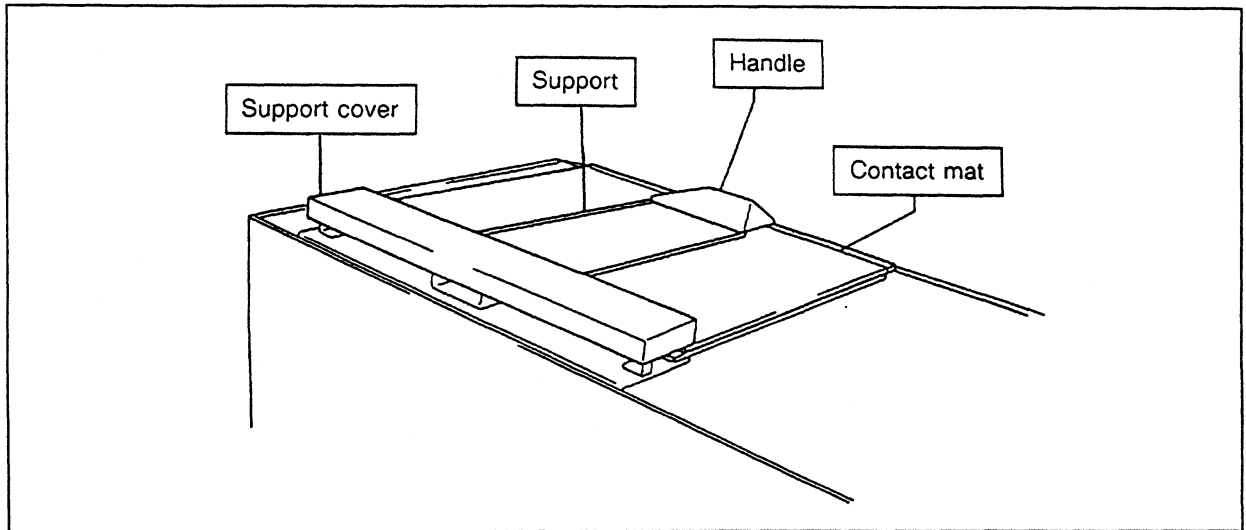

[How to Remove]

1. Turn the POWER switch OFF.
2. Loosen the screws (M3) of the support cover.
3. Gently lift the support cover and loosen the base side hinge fixing bolt (M4).
4. Remove the hinge and take off the contact mat.

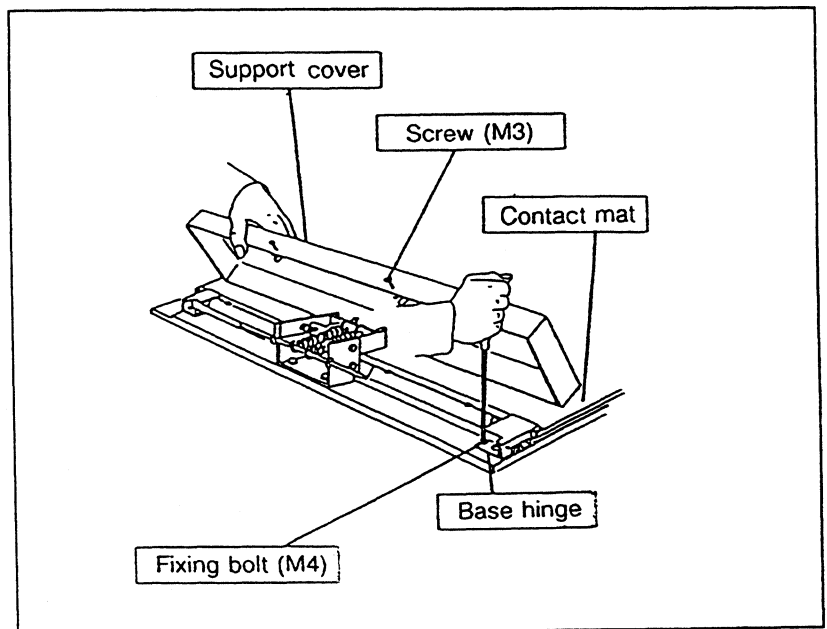

[How to Install]

1. Place a new mat in position.
2. Install in reverse order.

10. REPLACING THE COPY POSITIONING SHEET

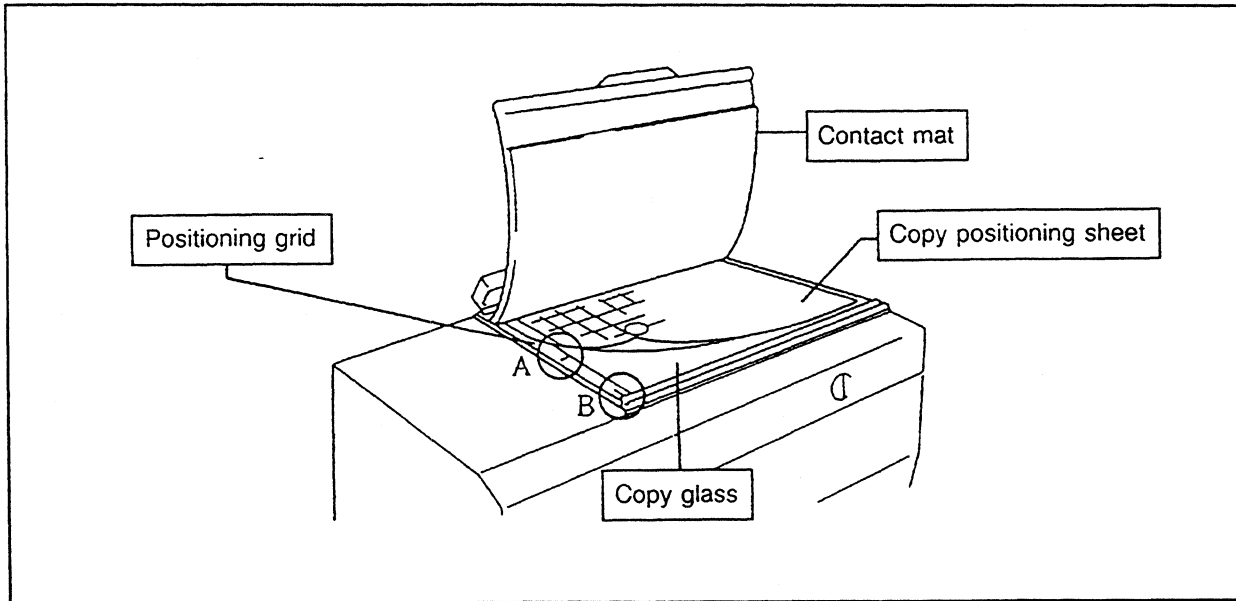

[How to Remove]

1. Turn the POWER switch OFF.
2. Remove the contact mat. (See procedures for replacing the contact mat.)
3. Loosen the securing bolt of the copy positioning sheet retainer and remove the sheet retainer.
4. Remove the copy positioning sheet.
 - ▶ *When removing the copy positioning sheet, check its positional relationship with the positioning grid, and mark with a line so that it can be replaced to exactly the same position.*

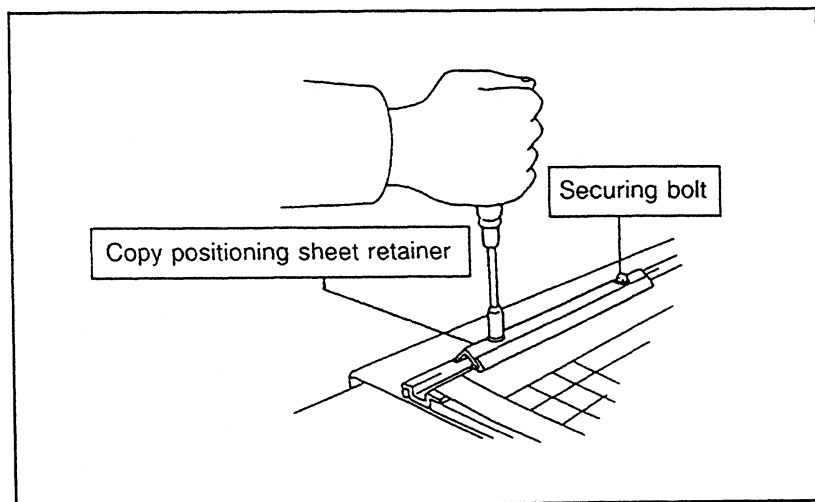

[How to Install]

1. Place a new copy positioning sheet aligned with the positioning grid.
2. Secure the copy positioning sheet onto the copy positioning sheet retainer using the retainer securing bolts.
(If uneven tension is applied to the sheet, loosen the securing bolt and secure again.)
3. Place a black sheet on the copy glass and make an exposure of the copy positioning sheet.
4. If the copy positioning sheet is correctly positioned, place the contact mat back in position.

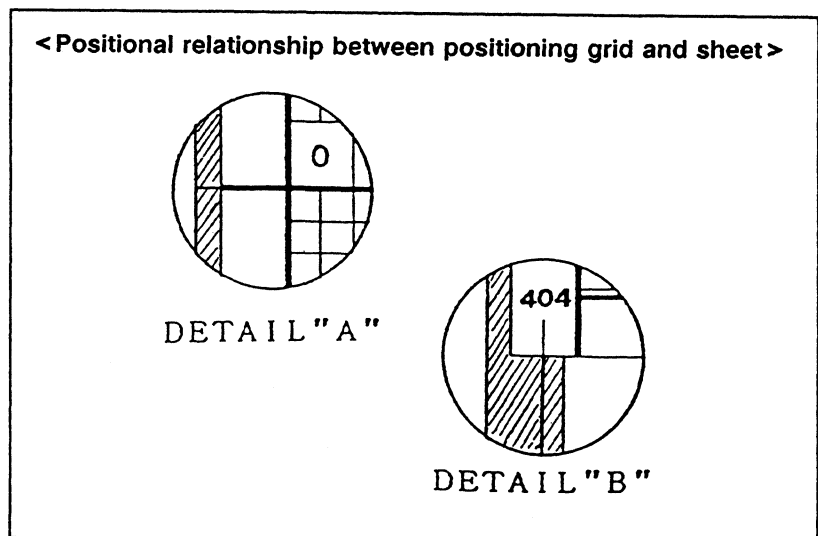

11. REPLACING THE COPY GLASS

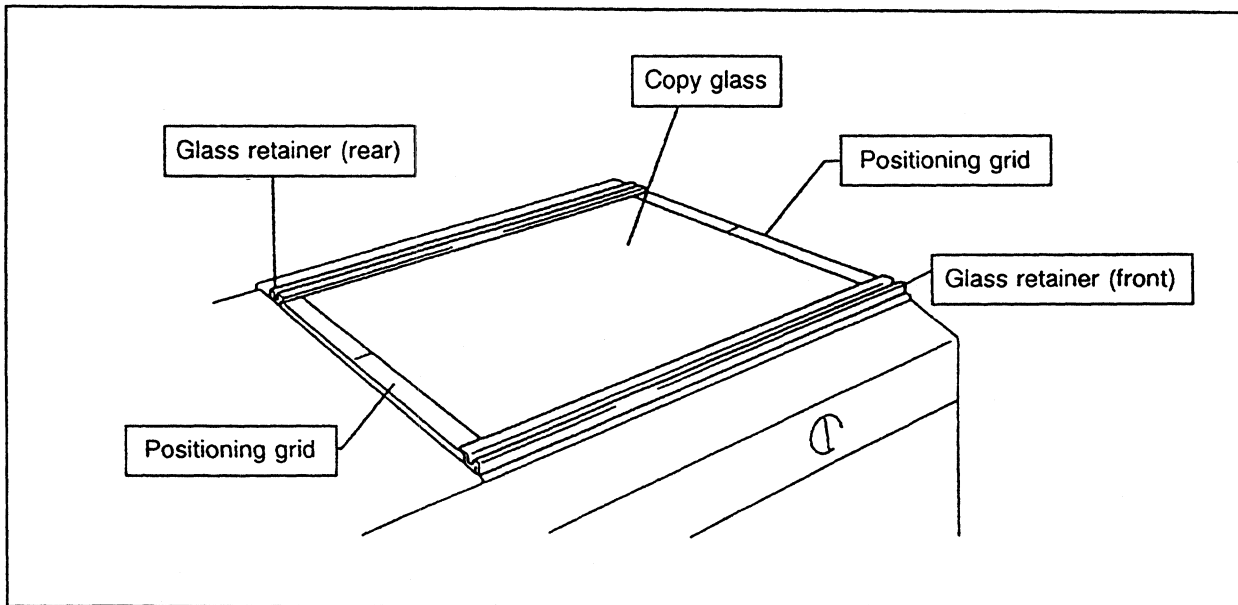

[How to Remove]

1. Turn the POWER switch OFF.
2. Remove the contact mat and the copy positioning sheet. (See the procedures for removing the contact mat and the copy positioning sheet.)
 - ▶ *When removing the copy positioning sheet, mark the part that is not to be removed for positional repeatability.*
3. Remove the handle from the support and leave it so that the tension spring is not acting (support lifted up).
4. With the support cover raised, loosen the holder bracket fixing bolt (M4).

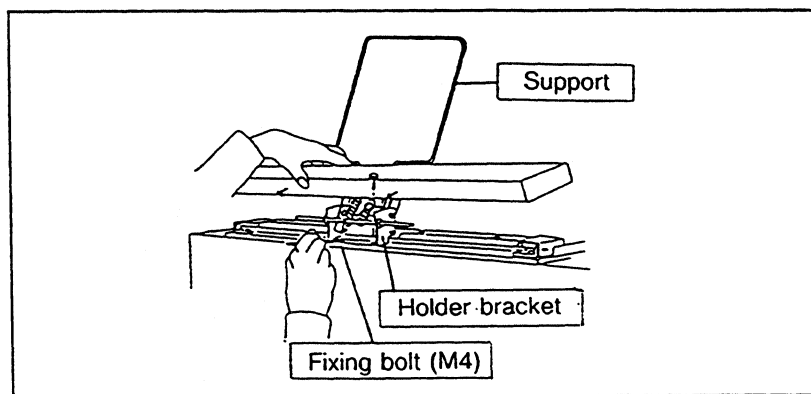

-
5. Remove the support section.
 6. Loosen the fixing bolts from the glass retainer (rear).
 7. Loosen the fixing bolts from the glass retainer (front), and remove the glass retainer.
 8. Remove the copy glass.

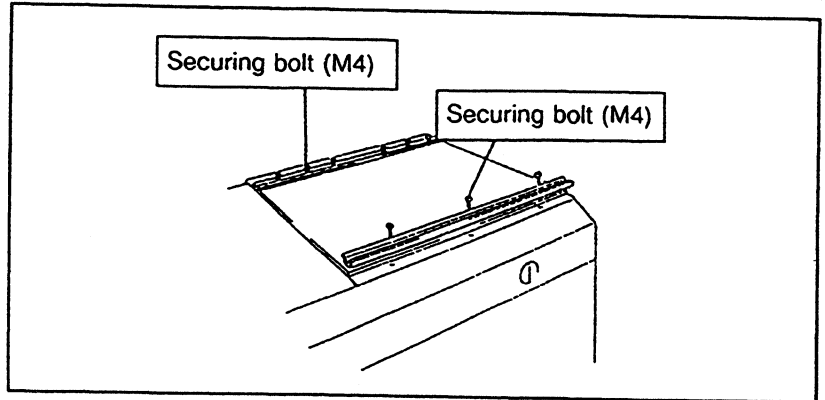

[How to Install]

1. Place a new copy glass in position.
2. Secure the front and rear copy glass retainers.
3. Align the copy positioning sheet with the marked line and secure.
4. Make an exposure of the copy positioning sheet.
5. If the copy positioning sheet is correctly positioned, align the positioning grid with the reference lines of the copy positioning sheet and affix to the copy glass.
6. Place the contact mat back in position.

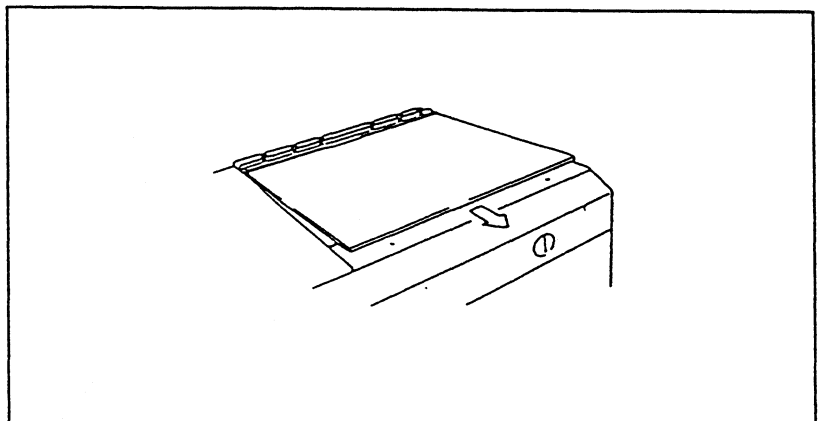

12. REPLACING THE DEVELOPER BELT

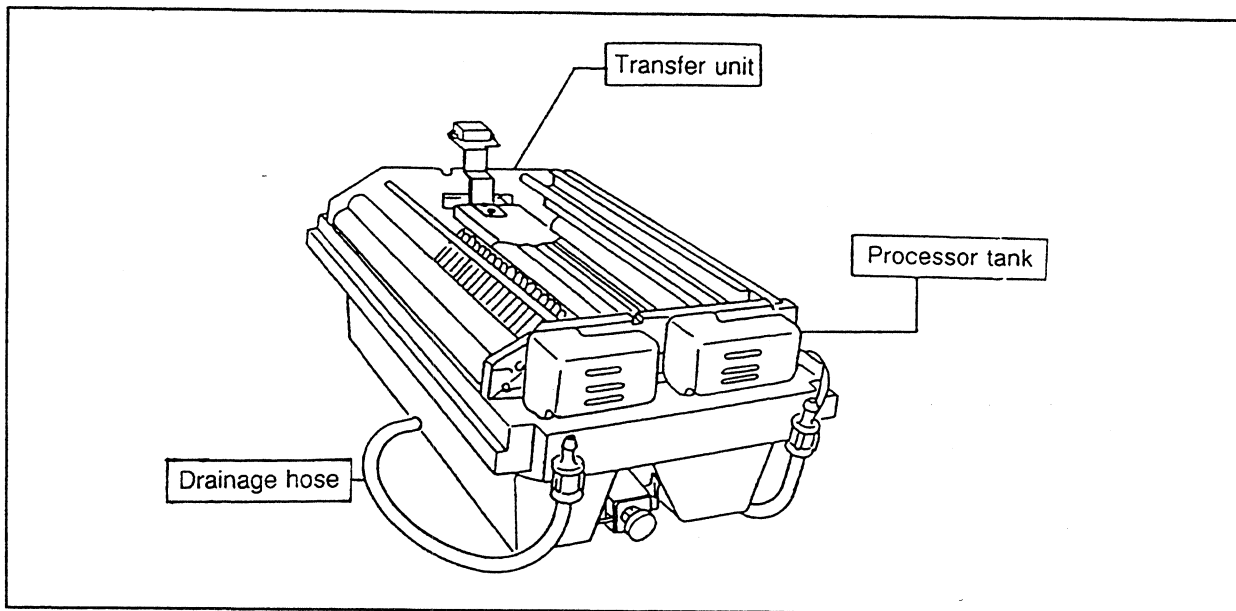

[How to Remove]

1. Turn the POWER switch OFF.
2. Remove the transfer unit from the processor unit.
3. Loosen the chain tension sprocket of the unit drive chain.
4. Remove the chain.
5. Remove the belt follower roller, belt tension roller and the E-ring of the belt drive shaft.
6. The developer belt can be removed by shifting the roller at the drive chain side.

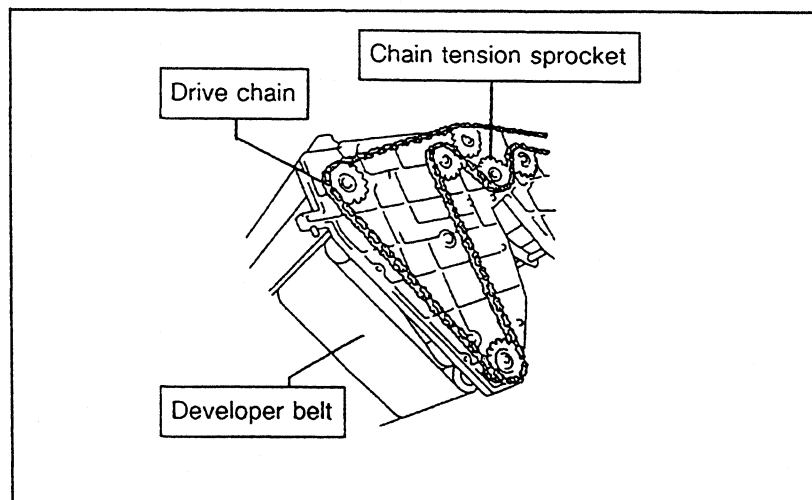

[How to Install]

1. Place a new developer belt in position.
2. Install in reverse order.
3. Check operation of the transfer unit.

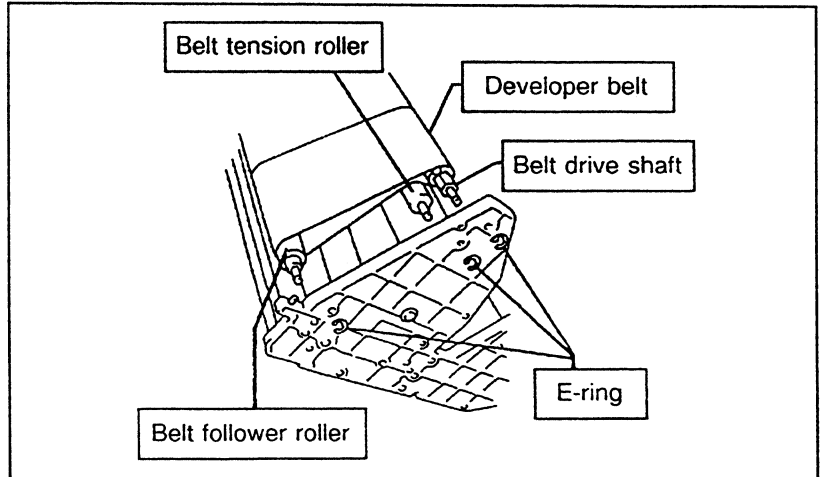

13. REPLACING THE HALOGEN LAMP

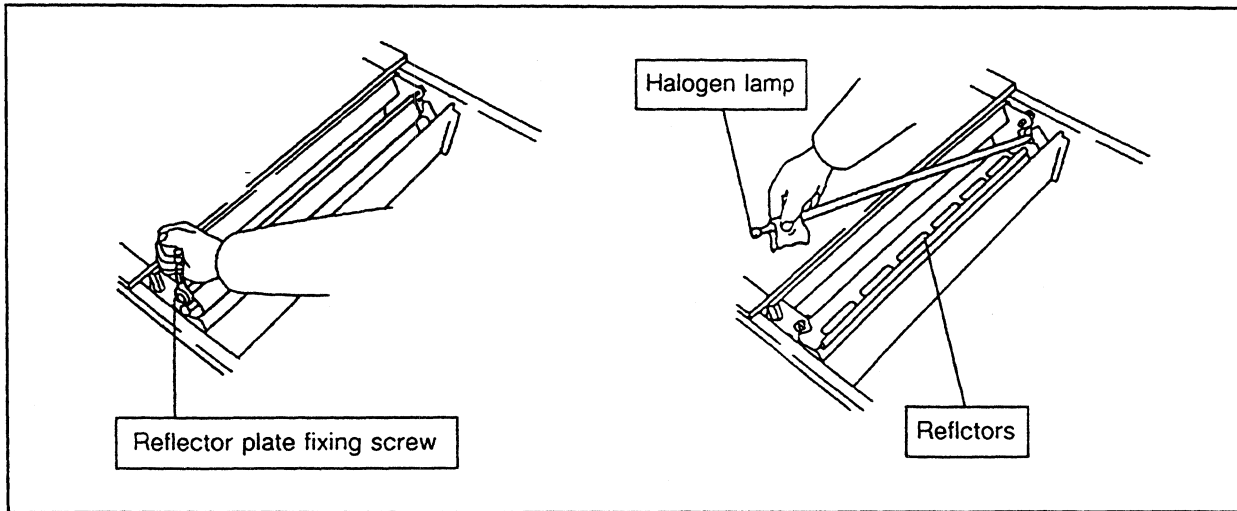

* Allow the lamp and reflector plate to cool before replacing.

[How to Remove]

1. Move the nip float handle to the FREE (♂) side.
2. Move the copy section to the left in STANDBY status.

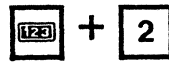

3. Turn the power switch OFF.
4. Remove the master side upper cover.
5. Remove the reflector plate fixing screw.
6. Remove the lamp.

[How to Install]

1. Install the new lamp.

- ▶ *Do not touch the lamp with your bare hands.*
- ▶ *Finger grease or dirt on the lamp will reduce operating life and cause uneven illumination.*
- ▶ *If the lamp is dirty, wipe it gently with lens paper (available at most camera shops) and a small amount of commercially available alcohol.*

2. Turn the power switch ON.

3. Put into "STANDBY" and confirm that the lamp is lit.

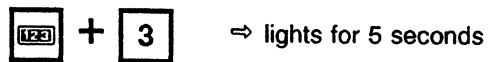

4. Install the reflector plates and master side upper cover.

5. Return the copy section to the right (origin point).

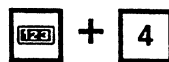

6. Release from "STANDBY"

14. PROCESSOR DRYER

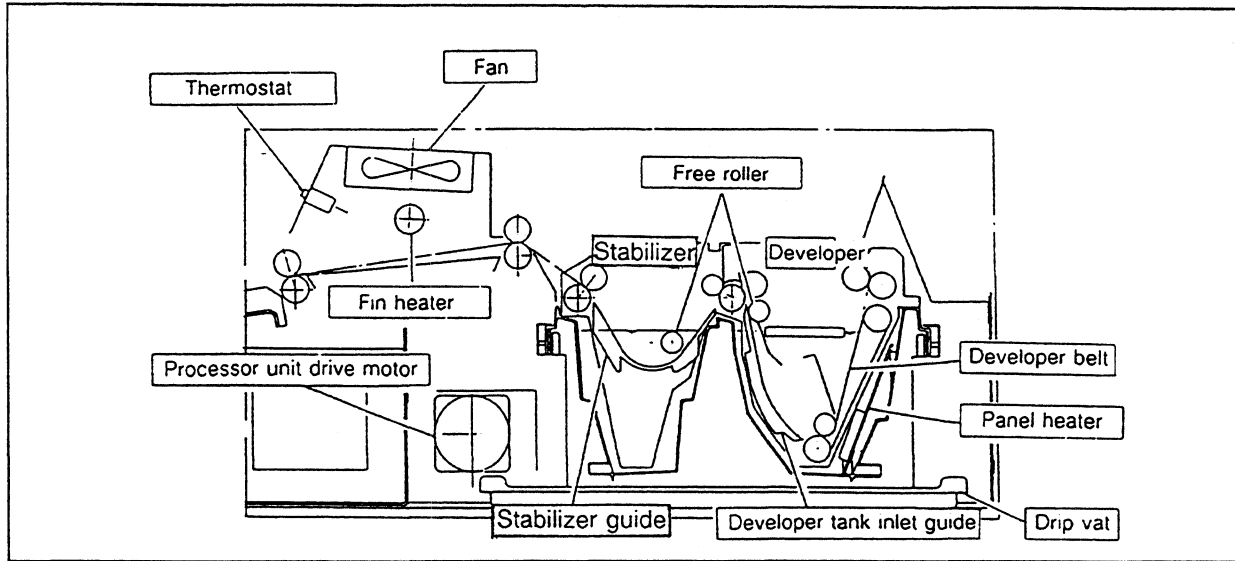

When the master becomes scratched in the processor dryer unit

Generally the following are considered as causes.

- Foreign objects or dirt are present at inlet guide.
→ Wash and clean.
- The free rollers are dirty and do not rotate smoothly.
→ Wash and clean.
- The dryer fan is not rotating.
→ Check the electrical system.

When the master becomes wrinkled in the processor dryer unit

Generally the following are considered as causes.

- The master worms due to faulty positioning in the loading section.
→ Check and load properly.
 - Cutter blade is blunt.
→ Replace the cutter blade.
 - Adhesive on parts (rollers, etc.) in the exposure section and transfer unit slow down the feed of the master and cause worming.
→ Clean.
 - The processor unit inlet guide is warped or foreign objects are attached.
→ Adjust and clean.
 - The nip pressure spring at the dryer inlet and outlet has come away.
→ Replace in position.
 - Temperature of dryer is too high.
→ Adjust thermostat. (Turn counterclockwise to lower temperature.)
- ▶ *Thoroughly check at which process the trouble is occurring and adopt the necessary measures.*

15. MAINTENANCE

Carry out the following items every day so as to use the functions of the machine to the maximum and to maintain the machine in an optimum state.

15.1 Maintenance Mode

The maintenance mode is used for checking operations and for carrying out general maintenance.

- ▶ *The maintenance mode can be entered when "STAND BY" is displayed.*

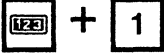
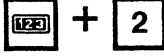
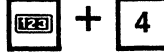
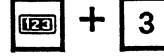
	Item	Key Operation	Purpose and Operation
1	Independent operation of cutter	 Press 1 while pressing count key.	<ul style="list-style-type: none"> ▶ To check cutter operation. • Cutter moves forward (cutting direction), and returns to its origin after reaching reverse sensor.
2	Independent operation of copy table NOTE: First set nip roller to (0°).	 Press 2 while pressing count key. Turn the power switch off.  Turn the power back on. Then press the "4" key while holding down the count key.	<ul style="list-style-type: none"> ▶ 1. To replace halogen lamp light source ▶ 2. To clean copy glass • Copy table moves to left and stops at end point sensor. • Copy table moves right to return to origin. If it has not contacted end point sensor, resetting machine returns copy table to origin.
3	Independent lighting of halogen lamp light source	 Press 3 while pressing count key.	<ul style="list-style-type: none"> ▶ To check lighting of halogen lamp light source • Lamp lights for 5 seconds and goes out automatically.

15.2 Copy Glass

If dirty, wipe clean with a cloth and commercially available glass cleaner. Take care not to leave any glass cleaner on the copy glass.

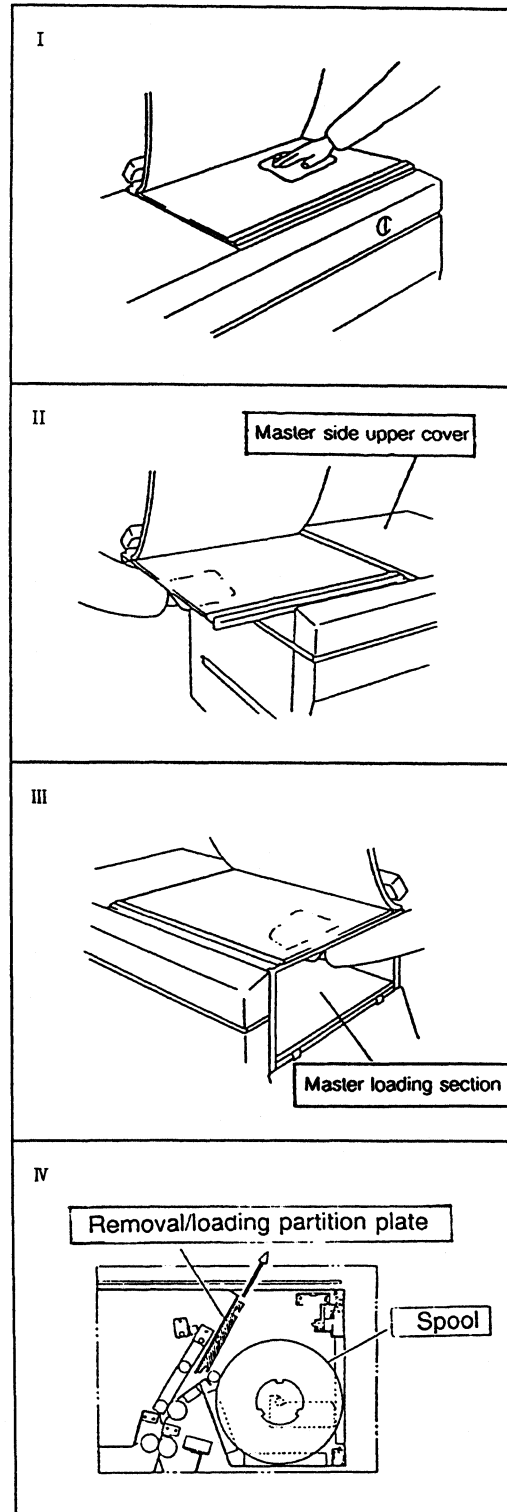

① Put the nip float handle on the free (δ) side.

② Move the glass to the left when "STANDBY" is displayed.

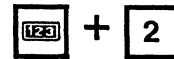

③ Turn the power switch OFF.

④ Remove the master side upper cover and the removal/loading partition plate in the direction of the arrow. (See IV.)

⑤ Turn the power switch ON again.

⑥ Move the glass to the right when "STANDBY" is displayed.



⑦ Move the copy glass to the left, and install the removal/loading partition plate and master side upper cover.

15.3 Lubricating

Frequency of lubrication depends upon frequency of use, but use the following as a guide.

- 1. Shell Tellus #27 or equivalent oil is recommended. (monthly)
- 2. Use a minimal amount of oil.

① Copy rail

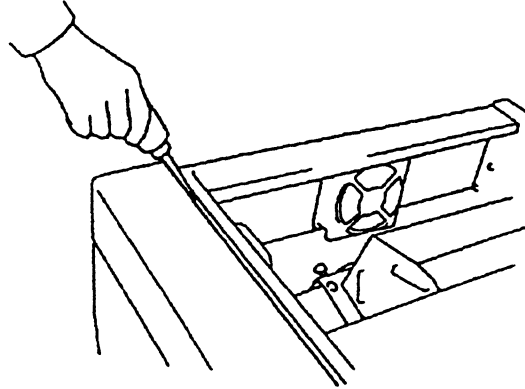

② Cutter chain

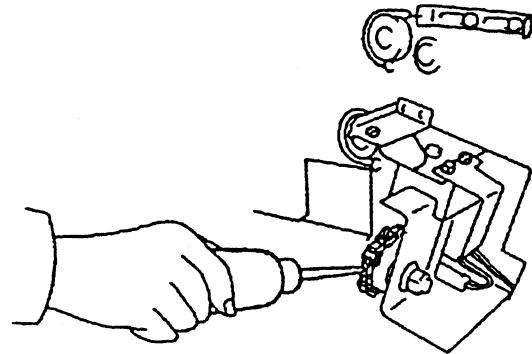

③ Processor
Dryer roller interlocking chain

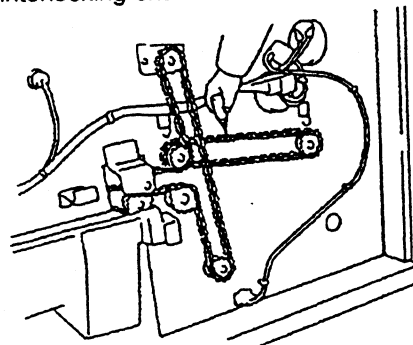

16. TROUBLESHOOTING

16.1 Error Messages

Error messages are displayed when the machine is not functioning normally for some reason or another.

If an error message is displayed, first of all turn the POWER switch OFF and then back ON again. Wait about five seconds and try operating the machine again. If the error message has not been cancelled and the machine does not operate normally, confirm the following check points.

Display	Symptom	Remedy
ERR1	Even though cutter goes forward (in cutting direction) and contacts reverse sensor, it is returned to origin without stopping.	<ul style="list-style-type: none"> ① Faulty cutter reverse sensor (PS6). Replace. ② Faulty connector connection. Check for broken wires.
ERR2	Although cutter reverse after cutting, cutter motor stops without cutter stopping at origin sensor.	<ul style="list-style-type: none"> ① Faulty cutter origin sensor (PS5). Replace. ② Faulty connector connection. Check for broken wires.
ERR3	Although copy table has moved within the specified time, after pressing start key, it does not stop at the prescribed position or stops at the end sensor (PS4).	<ul style="list-style-type: none"> ① Check the contact between the copy section and cover. ② Check for drive belt slip. ③ Faulty master feed sensor (PS2). Replace. ④ Faulty connector connection. Check for broken wires. ⑤ Faulty installation or rotation of encoder at center as viewed from rear (non-operating side) of body.
ERR4	Operation is stopped after the first exposure in automatic two-image exposure mode if the copy table does not return to its set position within the prescribed time limit. (The set position varies with the master feed and original lengths.)	<ul style="list-style-type: none"> ① Faulty original return sensor (PS1). Replace. ② Faulty connector connection. Check for broken wires. ③ Faulty installation or rotation of encoder at center as viewed from rear (non-operating side) of body.
CUT CHECK	Master is discharged without being cut even if exposed.	<ul style="list-style-type: none"> ① Check for broken cutter blade. ② Check when ERR2 occurs.