

**MITSUBISHI GRAPHIC ARTS SYSTEM**

**CP-414<sup>S</sup>**

## **WARNING**

This equipment generates uses and can radiate radio frequency energy and if not installed and used in accordance with the instruction manual, may cause interference to radio communications. It has been tested and found to comply with the limits for a Class A computing device pursuant to Subpart J of Part 15 of FCC rules, which are designed to provide reasonable protection against such interference when operated in a commercial environment. Operation of this equipment in a residential area is likely to cause interference in which case the user at this own expense will be required to take what ever measures may be required to correct the interference.

# CONTENTS

1. INTRODUCTION .....	3
2. SPECIFICATIONS .....	4
3. OVERVIEW .....	5
4. CUTAWAY SIDE VIEW .....	6
5. PRECAUTIONS .....	7
6. SITING CONDITIONS .....	8
7. PARTS NAMES AND FUNCTIONS .....	9
7-1 Overall Configuration .....	9
7-2 Description of Parts .....	10
7-2-1 POWER switch .....	10
7-2-2 Control panel .....	11
7-3 Copy Table .....	17
7-3-1 Mounting the copy .....	17
7-3-2 Positioning the copy .....	17
7-4 Lens and Mirrors .....	18
7-5 Exposure Section .....	19
7-5-1 How to set the master in place .....	19
7-5-2 "EMPTY" display .....	20
7-5-3 Detecting the master joint .....	20
7-6 Processor Unit .....	21
7-6-1 Preparing solutions .....	21
7-6-2 Activator tank (capacity 7 liters) .....	21
7-6-3 Stabilizer tank (capacity 6 liters) .....	22
7-6-4 Replenishing solutions .....	22
7-6-5 Replacing solutions .....	22
7-6-6 Maintaining Solution Levels I .....	22
8. OPERATION .....	23
8-1 Operational Procedure .....	23
8-2 How to Calculate the Standard Exposure .....	24
8-3 How to Calculate the Exposure for Specific jobs .....	25
9. MAINTENANCE .....	26
9-1 Maintenance Mode .....	26
9-2 General Maintenance .....	27
9-2-1 Processor unit .....	27
9-2-2 Replacing the cutter knife .....	28
9-2-3 Copy glass .....	29
9-2-4 Lens and mirrors .....	30
9-2-5 Cleaning the dryer's feed roller .....	30
9-2-6 Replacing the halogen lamp .....	31

<b>10. TROUBLESHOOTING .....</b>	<b>32</b>
10-1 Error Messages .....	32
10-2 Cutter Malfunction .....	32
<b>11. OPTIONAL EQUIPMENT .....</b>	<b>33</b>
11-1 Part names .....	33
11-2 Explanation of the control panel .....	34
11-3 Making and changing replenishment settings .....	35
11-3-1 Automatic replenishment mode .....	36
11-3-2 Startup Replenishment Mode .....	36
11-4 Maintaining Solution Levels II .....	37
<b>12. WIRING DIAGRAMS .....</b>	<b>38</b>

# 1. INTRODUCTION

Thank you for your purchase of the CP-414S.

The Silver Master CP-414S can be used for A4 to A3 size masters by combining it with the Silver Master R II (SLM-R II) and Silver Master F (SLM-F) photosensitive materials. Through a simple onetouch operation, an master can be made directly without the necessity of film-making.

This Operation Manual has been made so as to ensure prolonged use of the outstanding functions of the CP-414S. Please read it before actual operation.

See the Silver Master Technical Guide for details on printing.

## 2. SPECIFICATIONS

Master in use :	1 roll (SLM-RⅡ, SLM-F)
Master width :	229 mm (9") , 254 mm (10") , 279 mm (11") , 305 mm (12") 310 mm (12 1/5") , 370 mm (14 9/16) , 404 mm (15 7/8) 414 mm (16 3/10")
Master feed length :	225 ~ 550 mm (settings in 1mm increments)
Eff. exposure size :	404 × 540mm
Max. exposure size :	414 × 550mm
Eff. copy size :	404 × 540mm
Max. copy board size :	495 × 600mm
Lens :	Fixed aperture, focal length = 210mm, F=11
Magnification :	100 % (fixed at actual size)
Exposure method :	Movable copy and master slit exposure system
Copy mounting :	Copy facing down. with 180 mm pin bar
Multiple exposure :	Automatic two-image exposure, multiple exposure
Cutter :	Slide cutting system
Exposure adjustment :	Digital illuminance adjustment 0 ~ 99
Light source :	Halogen lamp, 80V 800W × 1
Control panel :	Flat panel, interactive input
Master joint detection :	Display message, alarm buzzer, automatic over cutting
Dehumidifier :	Heater type
Processor unit capacity :	Activator 7 liters, stabilizer 6 liters
Replenisher solution amount :	Activator 1 liter, stabilizer 1 liter
Initial plate time :	1 min 58sec (at 450mm feed) / 60HZ
Cycle time :	52sec (at 450mm feed) / 60HZ
Copy feed speed :	19.0mm/sec / 60HZ
Processor unit feed speed :	12.0mm/sec / 60HZ
Solution temp. control :	350W panel heater (with safety thermostat) , 29± 3 °C , heater OFF during exposure
Dryer :	400W fin heater 2-stage thermal control (HIGH, LOW) selectable
Safety interlock :	Meets safety standards
Power supply :	AC. 220/220/240V 1.5KW
Machine dimensions (W×D×H) :	1000 × 695 × 790 mm (body only) 1000 × 695 × 1030 mm (with legs)
Weight (without solutions) :	135kg
Options :	Replenisher unit

### 3. OVERVIEW

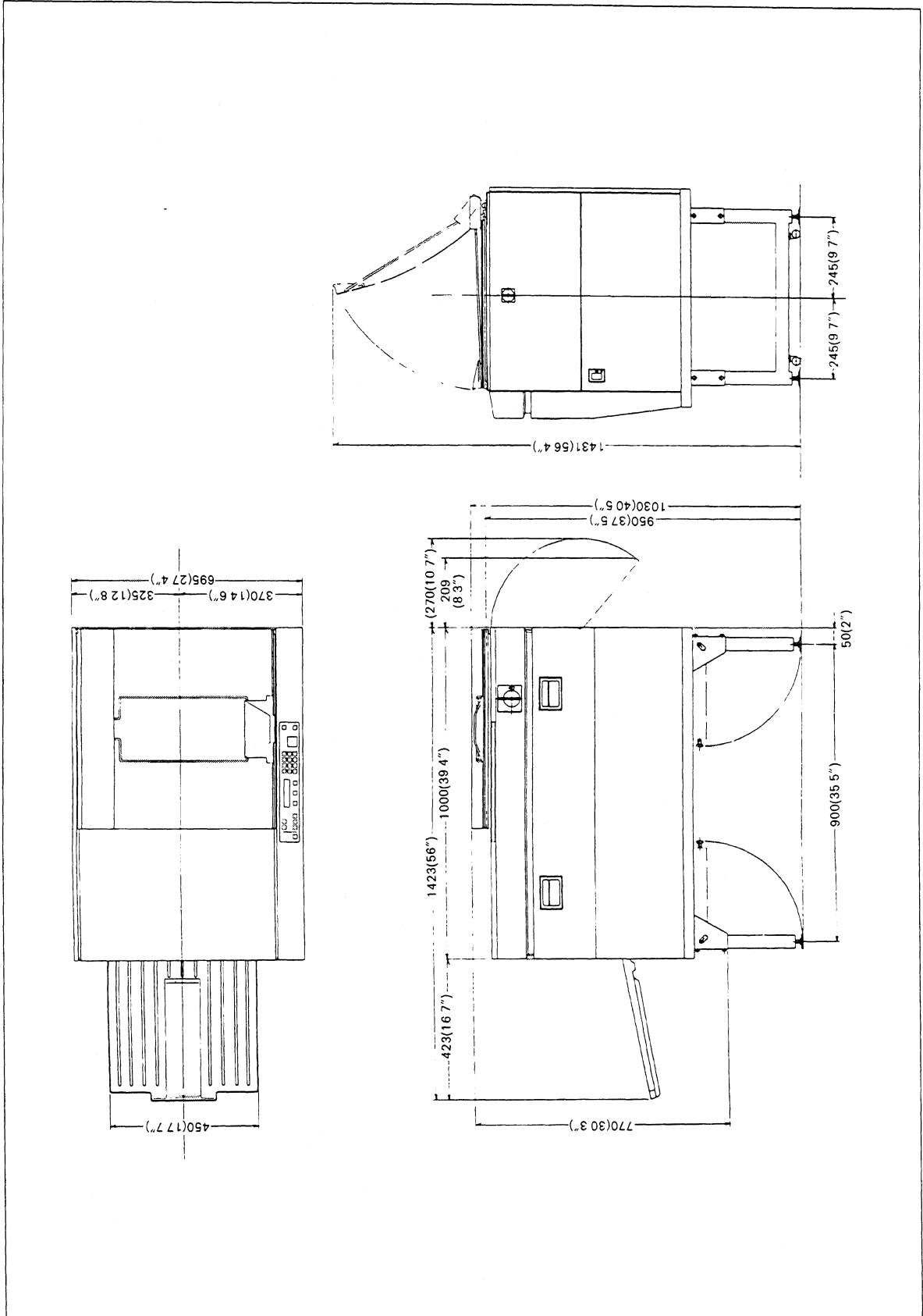

# 4. CUTAWAY SIDE VIEW

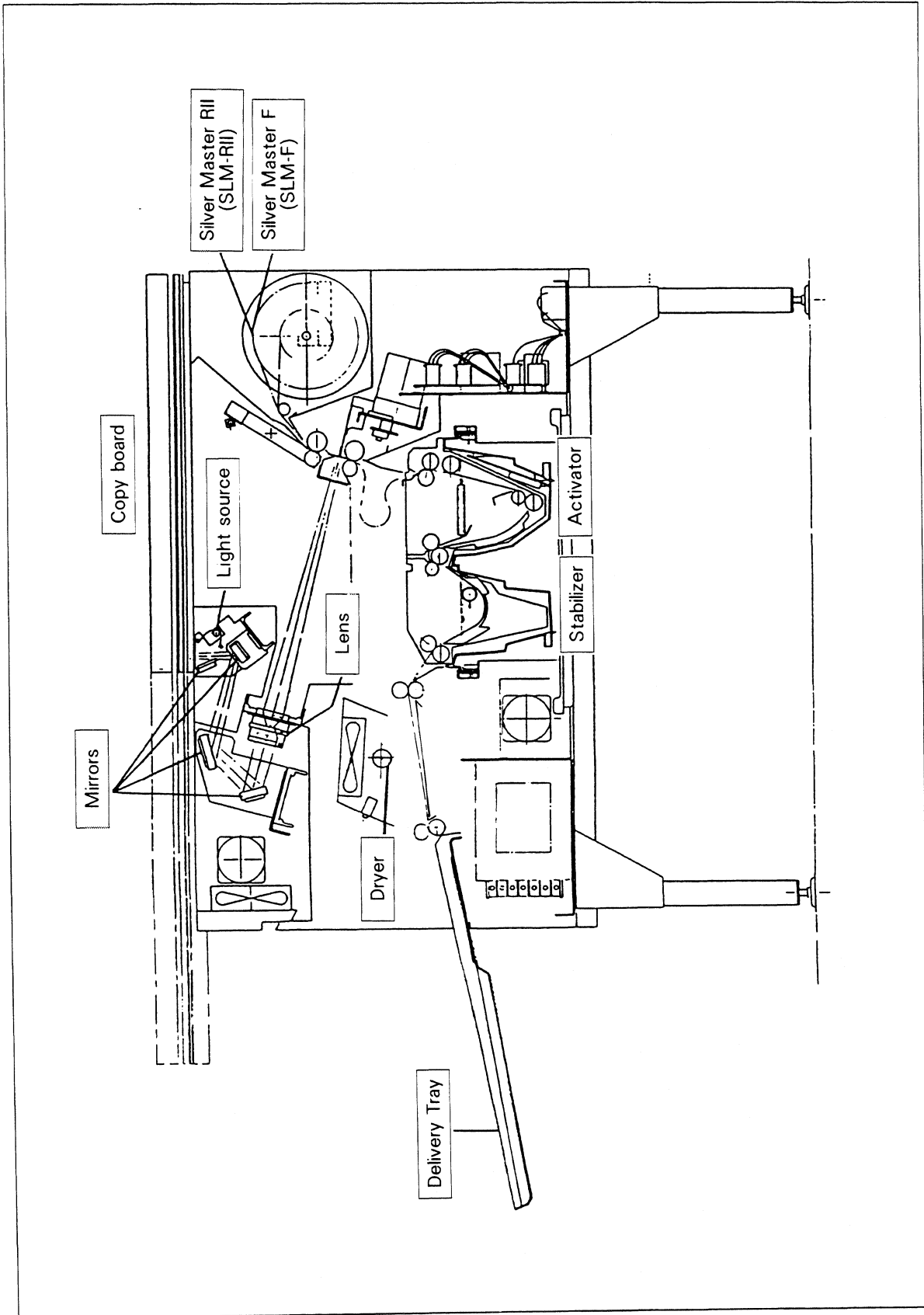



## 5. PRECAUTIONS

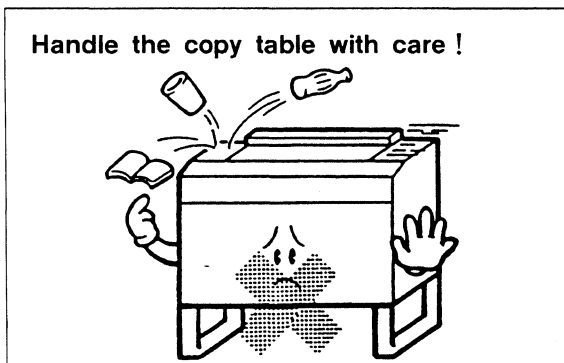

Do not place objects on the copy table. The copy table moves to the left when the start pushbutton is pressed.

## 6. SITING CONDITIONS

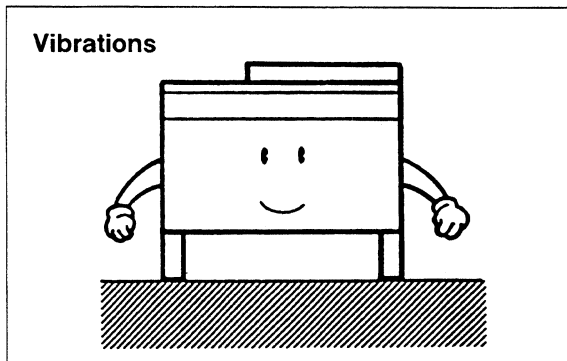

Site the machine on Horizontal flat area from vibrations.

The site must be strong enough to support its weight 135kg (without processing solutions)

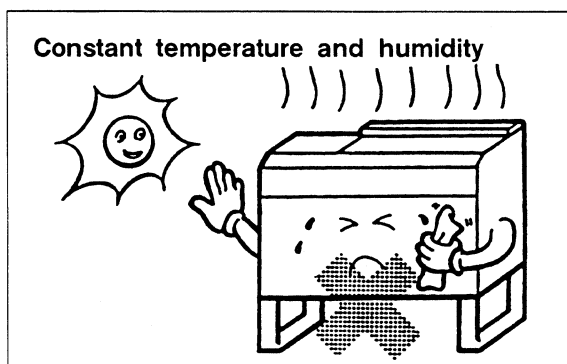

Site the machine at a location where the temperature is maintained within the range 10°C – 30°C and the humidity is within the range 40% – 70%. Avoid siting in the direct sunlight.

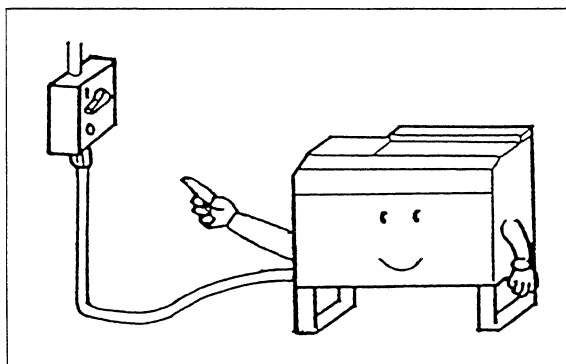

Be sure to connect the power code direct to the power distribution board provided with a switch or ground fault interruter.

Be sure keep the power cord connected permanently  
please ask an authorized electric engineer to do above.

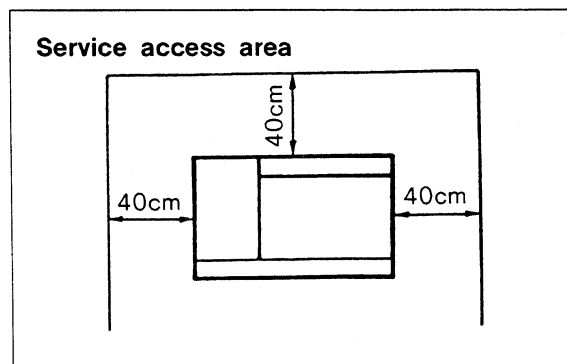

Maintain an area around the machine for easy access during servicing.

machine dimensions (W × D × H) :100 × 69.5 × 103 cm

# 7. PARTS NAMES AND FUNCTIONS

## 7-1 Overall Configuration

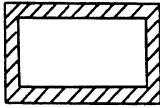

...The marked parts are to be touched by service man only and are not to be touched by user

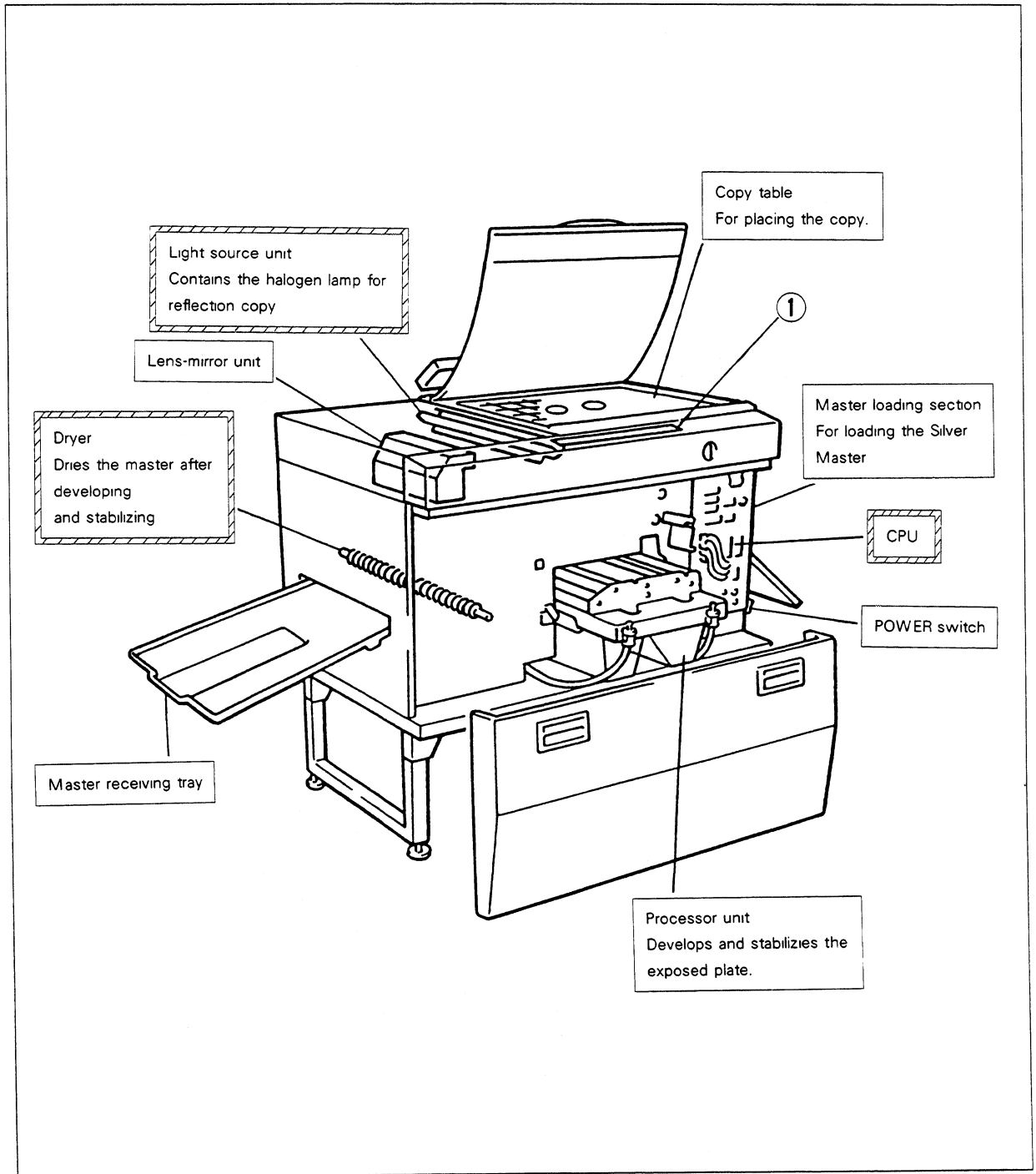

## 7 - 2 Description of Parts

### 7 - 2 - 1 POWER switch

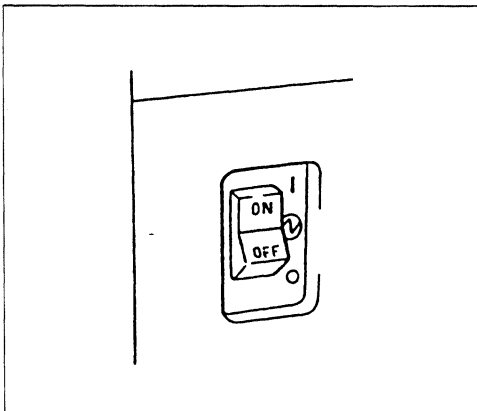

Turn this switch ON to supply power to the operating circuits, processor unit motor, dryer, panel heater, etc. The system then displays the following items for five seconds each as prompts for start-up inspection.

\* A few seconds are required for the display to appear after switching the unit on.

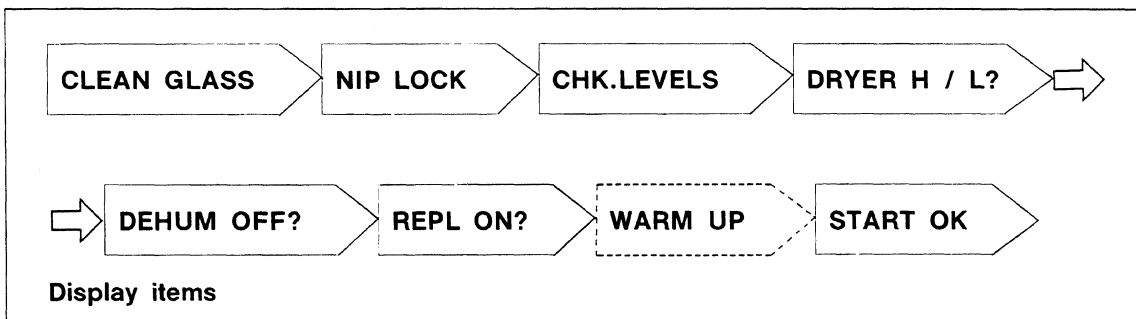

To pause, press the start key. To restart, press the **C** key.

NOTE:

**CHK.LEVELS** Check to be sure that there is sufficient replenisher in the tank before turning on the power.

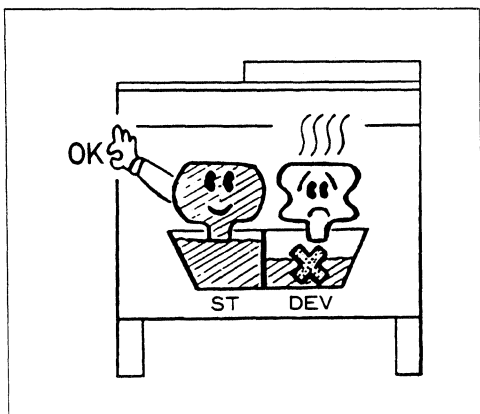

This check is especially important after heavy use or whenever the unit has not been used over an extended period of time (large replenishment volumes may be required to compensate for evaporation and oxidation losses) .

\* Perform the check by ensuring that the proper level of solution remains in the replenishment tanks. If insufficient, add more.

- When using the optional automatic replenishment unit, check the solution in the processor tanks. If need be, replenish up to the overflow mark, Refer to page for replenishment procedures

## 7 - 2 - 2 Control panel

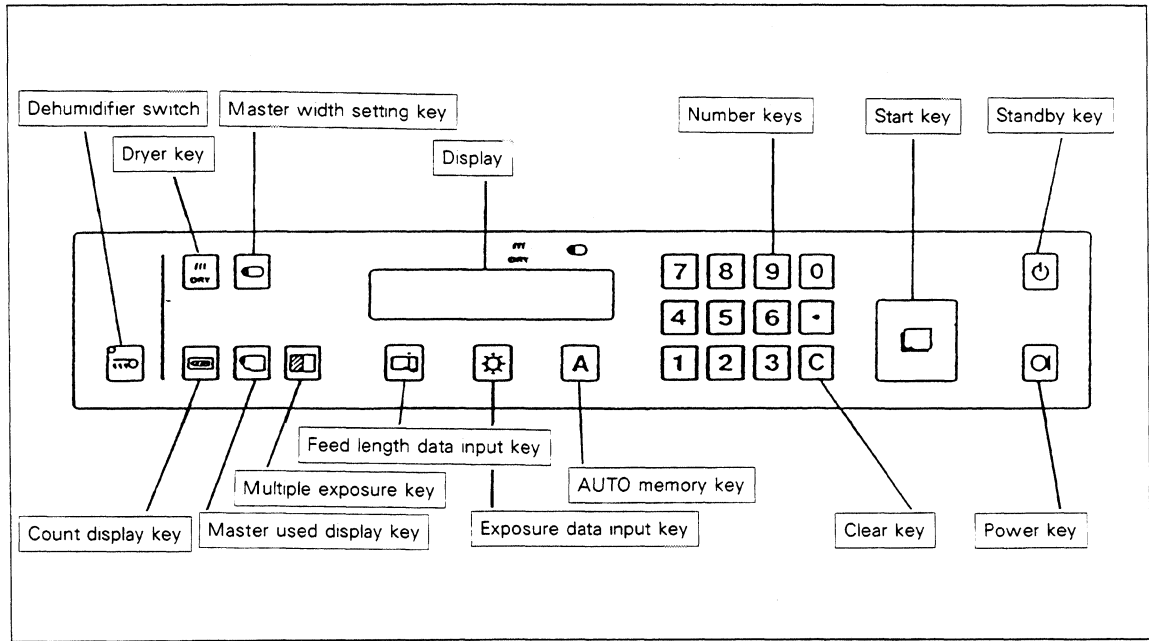

### ① Standby key



Press this key to temporarily stop operations, conserve energy or cancel standby status. When pressed, "STAND BY" will be displayed.

### ② Power key



When this key is pressed at shut-down, messages will be displayed prompting the operator to carry out certain inspections. The following items will be displayed for five seconds each.

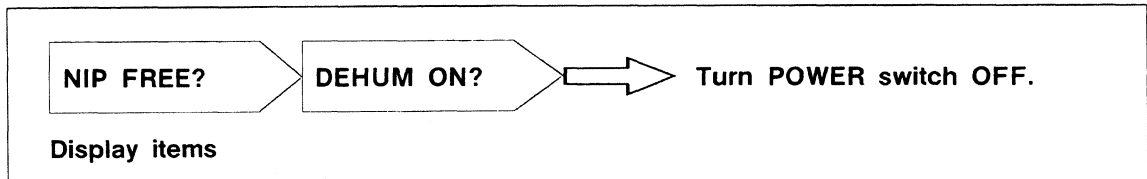

NOTE : Do not turn the POWER switch OFF when turning the dehumidifier ON

### ③ Start key



Press this key to start platemaking when "START OK" is displayed. This key also doubles for the following.

- 1) When pressed during start-up and shut-down inspections, the display status at that time is held. Press the **[C]** key to cancel.
- 2) Platemaking in the multiple exposure modes is enabled once the previous master has been completely discharged. The following messages will be displayed when this key is pressed before the master has been completely discharged  
"TRANSPORT"  
"WAITING"

④ **Number keys**



Keys for inputting numerical data.

⑤ **Feed length data input key**



This key is for storing the feed length (in mm units) to memory after keying in the value using the number keys. The master feed length will then be displayed.

NOTE : If data outside of the input range (225–550) is keyed in, “SET UP ERR” will be displayed. Erase the data using the clear key and re-input.

⑥ **Exposure data input key**



This key is for storing the exposure data to memory after keying in the value using the number keys. The exposure data will then be displayed.

(A value within the range 50 ~ 70 is the correct exposure value. Though this depends on the density of the copy.)

The higher the value, the larger the exposure becomes. Alternatly, the lower the value, the smaller the exposure becomes.

⑦ **AUTO memory key**



This key is for storing to memory frequently used values for the master feed length and exposure data. Press this key to call up a data setup for certain plate conditions.

- To input exposure data  
Key in the desired value using the number keys and press the AUTO memory key while holding the exposure data input key pressed down.
- To input feed length data  
Key in the desired value using the number keys and press the AUTO memory key while holding the feed length data input key pressed down.

⑧ **Master width setting key**



Press this key to display the width of the master in use after keying in the desired value using the number keys.

NOTE : This value must be input if the automatic replenisher unit (option) is connected.

The master width and master feed length data determines the area for replenishment. Solutions are replenished for every square meter of master plate processed.

⑨ **Dryer key**



This key is for setting the temperature of the dryer heater to either high (HIGH) or low (LOW). Set the temperature according to how dry the master is after processing.

- HIGH  
Use this setting (1) when the ambient temperature is low and the master plate is not being sufficiently dried, and (2) when Silver Master F (SLM-F) is used.
- LOW  
Use this setting when Silver Master R II (SLM-R II) is used.

⑩ Multiple exposure key



This key is for enabling multiple exposure (automatic two image exposure, multiple exposure)

1) Automatic two-image exposure

///       
**DRY**

START OK	L	404
400 mm	70	

**Standard exposure mode**



ORIG.LENG?	2 DIV	
400 mm	70	150



**Automatic two-image exposure**

START OK	2 DIV	045
400 mm	70	

Press the multiple exposure key once to select automatic two-image exposure. To cancel, press three times.

Key in the length of the original in response to the prompt "ORIG. LENG?" and press the feed length data input key

Ex :

Master feed length ..... 400mm  
 Original length ..... 150mm  
 Original position ..... 045mm

- The reference line at the left side of the original positioning sheet is 0. Place the original 45mm away from this line.
- Press the start key. An image of the original will automatically be exposed in succession at the center of two halves of the master which is then discharged.

NOTE : The value to be input in response to the prompt "ORIG LENG?" is a value half or less (as the area between the two images of the master is burnt out) of the master feed length. If too long a value is set, "SET UP ERR" will be displayed. To cancel, press the  clear key and re-input the data again.

2) Multiple exposure

///       
**DRY**

START OK	L	404
400 mm	70	

**Standard exposure mode**



START OK	DIV	200
	70	100



**Multiple exposure**

- Press the multiple exposure key twice to select multiple exposure. To cancel, press three times.

- Key in the length of the original in response to the prompt "ORIG. LENG?" and press the feed length data input key

Ex :

Master feed length ..... 400mm  
 Original length ..... 100mm

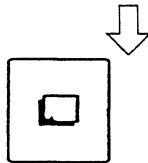
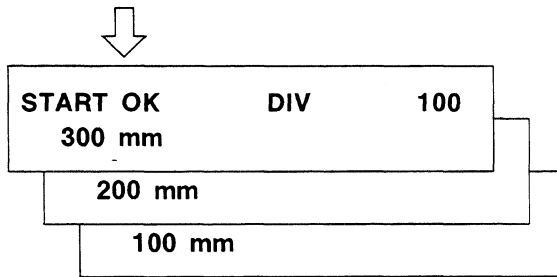
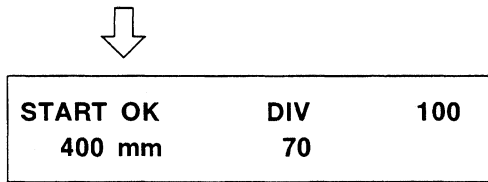

⑪ Master used display key

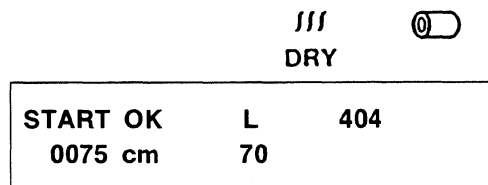

⑫ Count display key

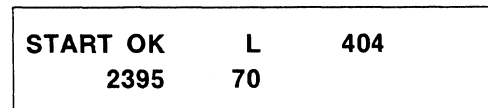

⑬ Dehumidifier switch



This turns the defogger for dehumidifying the atmosphere inside the machine ON and OFF.

This prevents the developer from condensing. Condensation is caused by rising humidity inside the machine as a result of the ambient humidity, and by sudden temperature change.

During overnight operation, etc., do not turn the  power key and POWER switch OFF

- The remaining amount of master plate is displayed each time that the start key is pressed.

Multiple exposure is performed until the total feed amount (master feed length) is reached.



If multiple exposure is performed for several masters and the length of the original and the remaining amount of master material are the same, it will be discharged automatically by pressing the start key.

If they are not the same, press the multiple exposure key.

- The total amount of film used so far is displayed for the time that this key is pressed.

Ex : 0075cm



This means that 75cm has already been used.

- To reset the display
  - 1) Press the  and  keys. The display will change to "0000".
  - 2) The display is automatically reset if "EMPTY" is displayed.

- The number of counts (number of plates made so far) is displayed for the time that this key is pressed

Ex : 2395

This means that 2395 plates have been processed.

- To reset the display  
Press the  and  keys. The display will change to "0000".



⑭ **Clear key**



This key is used to erase (or cancel) data on the display. It can also be used in the following instances:

- 1) To erase data when "SET UP ERR" is displayed.
- 2) To stop the buzzer from sounding when "EMPTY" is displayed or when replacing the master
- 3) To cancel an operation mid-way to alter the data, etc.

The light source will go out when the master has been fed a minimum length of 225mm, and the copy board will be returned to its mechanical origin after the master plate has been cut.

- 4) To skip check items displayed at start-up and shut-down inspections.

NOTE : If the clear key has been pressed while "WARM UP" is displayed, the master plate will not be properly processed as the ideal solution temperatures have not been reached. In this case, turn the power OFF and then ON again.

⑮ **Displays** 

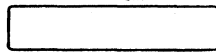

1. Status and error messages displayed during operation

**[Status messages]**

- A. EMPTY (accompanied by buzzer)  
A master (photosensitive materials) is not present.
- B. COPY POSIT  
The copy table is not at its origin.  
→Troubleshooting section. (p. 38)
- C. CUTTER ERR  
The cutter is not at its origin.  
→Troubleshooting section. (p. 38)
- D. SET UP ERR  
Data outside permissible range has been input.
- E. WARM UP  
Processing solutions have not reached preset temperature.
- F. ROLL JOINT (accompanied by intermittent buzzer)/WAITING  
The joint in the master plate has been detected.
- G. TRANSPORT/WAITING  
Master is being discharged.
- H. CHK REPL  
Check the automatic replenisher unit (option)
- I. START OK  
Platemaking can be started.
- J. DOOR !  
Close front panel.
- K. ORIG. LENG?  
Input the length of the original for multiple exposure.
- L. REPLENISH SOLUTION (accompanied by buzzer)  
Add replenisher to processor solutions.
- M. REPL IN WAITING  
Replenishment is in progress (option)

N. CHECK PROCESSOR (accompanied by buzzer)

Check processor for replenishment trouble.

2. Display of master width data
3. Display of exposure data
4. Display of master feed data
5. Display of dryer setting HIGH / LOW
6. Display of other data

## 7 - 3 Copy Table

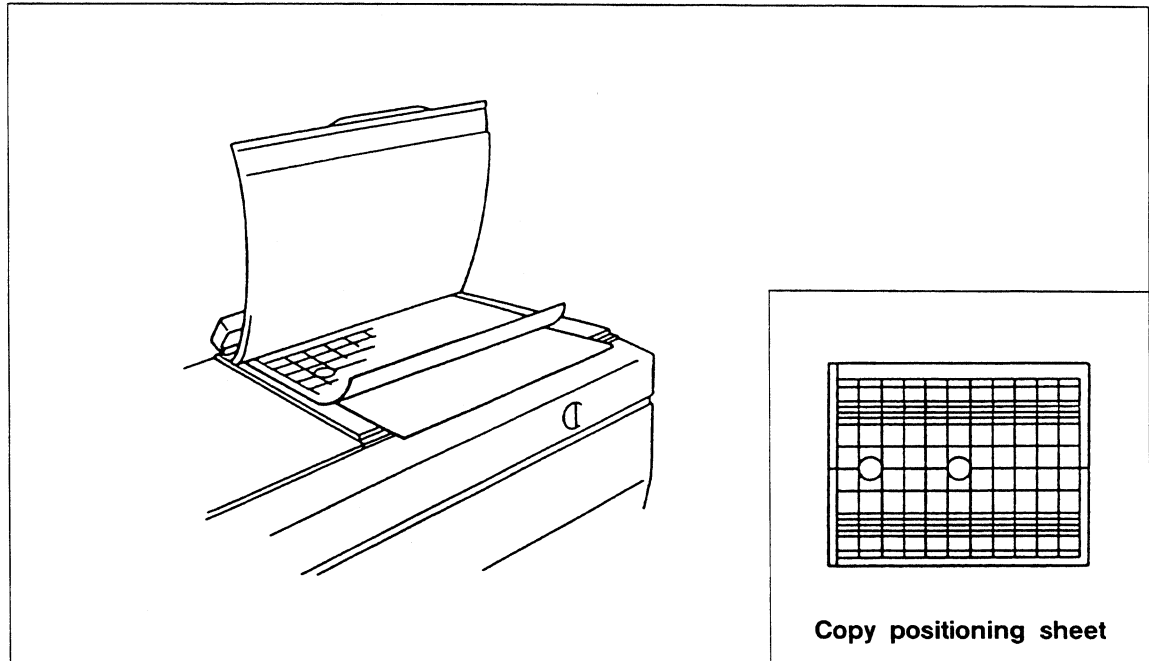

NOTE : Do not place objects on the copy table. The copy table moves to the left and right during operation.

Do not touch the copy table during operation.

### 7 - 3 - 1 Mounting the copy

① Gently lift up the copy cover by the handle on its front. Spring action will cause the copy cover to come to a stop at a fixed position. Do not take your hand away from the handle until the copy cover has risen up to this position.

② Mount the copy between the copy positioning sheet and copy glass.

NOTE · Do not suddenly lift up or lower the copy cover as this will damage the copy cover.

### 7 - 3 - 2 Positioning the copy

① The reference line of the copy positioning sheet is marked with two round circles. This indicates the leading edge of the master plate. As a section between the two images on the master is burnt out owing to the slit exposure system, the image cannot be exposed in this 5mm area.

② The copy positioning sheet is divided into 5mm interval grid. Use this grid for positioning the copy.

## 7-4 Lens and Mirrors

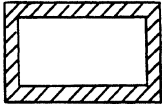

...The marked area to be touched by service man only and are not to be touched by user.

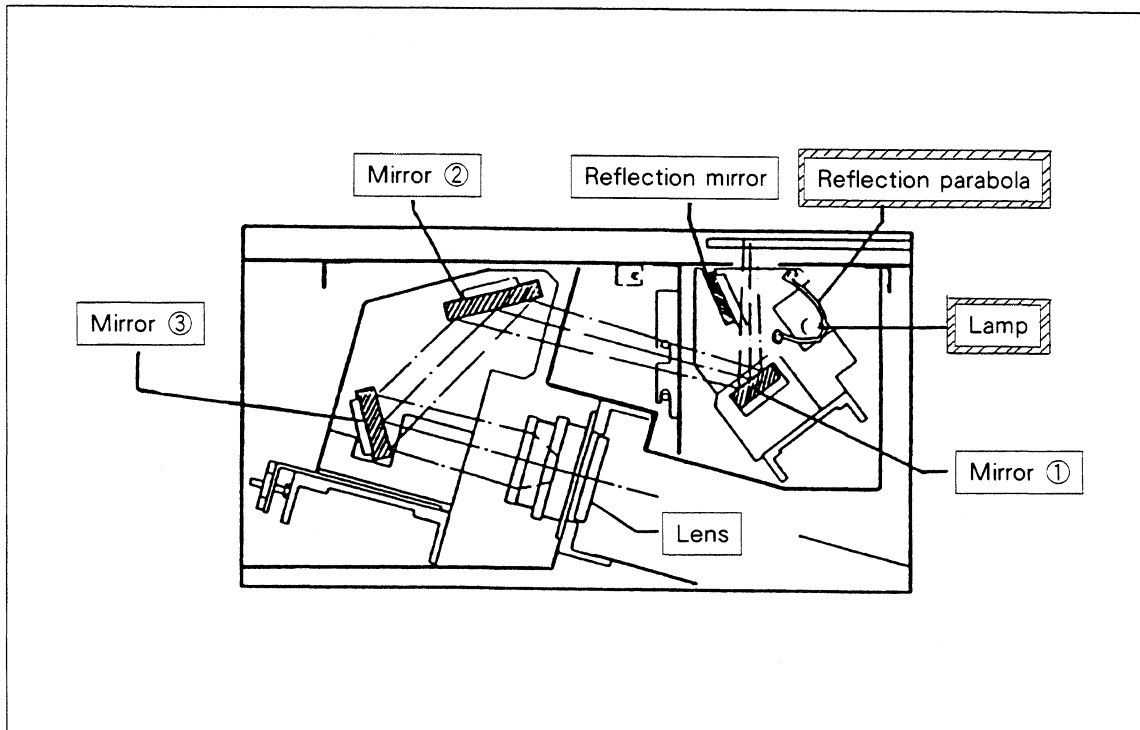

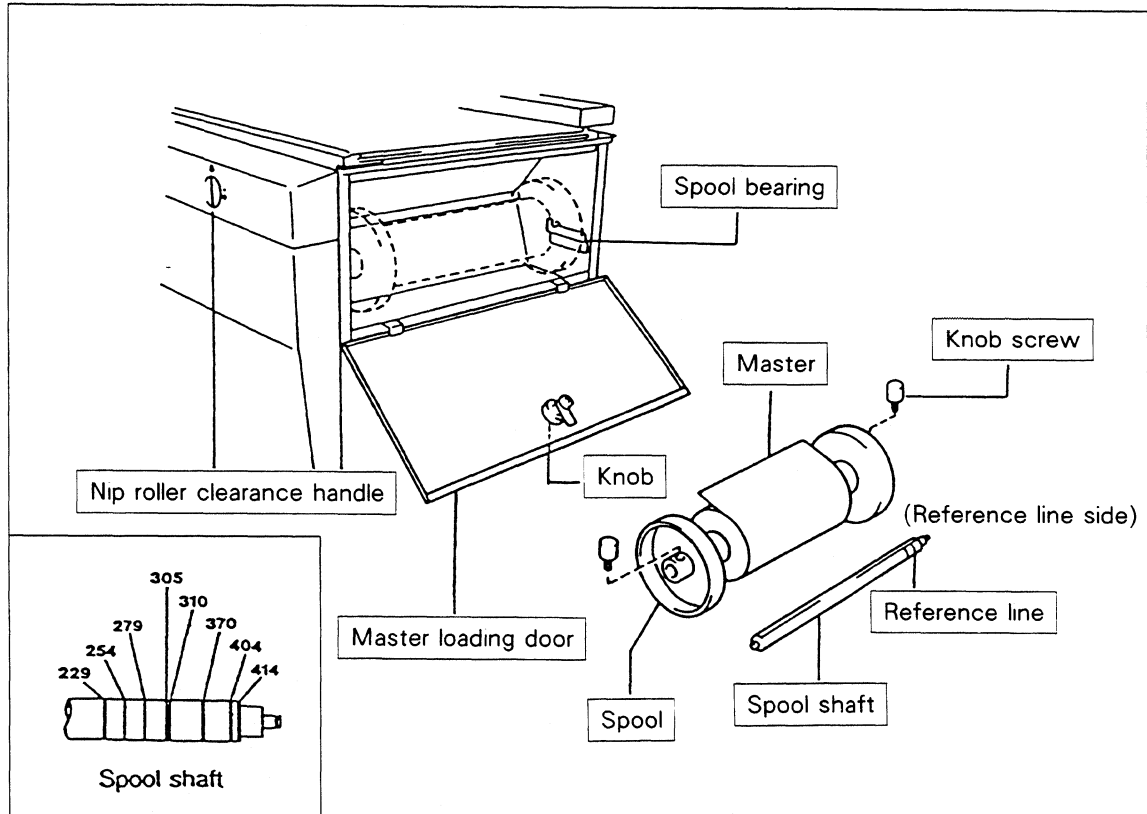

- The lamp lights up, and light reflected from the lamp itself, reflection parabola and reflection mirror is irradiated onto the surface of the copy.
- The light (image) reflected from the original is reflected at mirror ① passes through the lens via mirrors ② and ③ and is irradiated onto the master plate.
- The lens and mirrors are fixed. The copy table is fed to the left and the image of the copy is irradiated onto the master plate which is fed synchronized with the copy table. As the master plate is fed, the image is reproduced on the master plate.
- Several mirrors are used in the optical system. For this reason, do not install the machine in a dusty or humid site.

## 7-5 Exposure Section



### 7-5-1 How to set the master in place

#### 1) Loading Silver Master RII (SLM-RII)

- ① Turn the knob on the master loading door and pull towards you to open the door
- ② Align the spool with the reference line on the spool shaft in accordance with the width of the master in use (229 mm, 254 mm, 279 mm, 305 mm, 310 mm, 370 mm, 404 mm or 414 mm) and secure with a screw. (Secure by the screw on the flat surface of the spool shaft)
- ③ Pass the master through the spool shaft and fit the core of the master paper over the spool. Make sure that the master is wound to the right as viewed from the reference spool side
- ④ Insert the spool at the other side and secure by screwing
- ⑤ Attach the spool to the spool bearing.
- ⑥ Completely peel off the adhesive tape preventing the master from unfolding.  
NOTE : Do not leave any adhesive on the master.
- ⑦ Set the nip roller clearance handle to the free (  ) position.
- ⑧ The buzzer will stop sounding when the master is inserted between the feed and nip rollers. Feed the master in about 50 mm from that position.
- ⑨ Set the nip roller clearance handle to the lock (  ) position.
- ⑩ Close the master loading door.

#### 2) Loading Silver Master F (SLM-F)

- ① The SLM-F comes attached to a spool. Do not remove the spool. Load the spool as it is.  
NOTE : If the spool is removed, light will enter and expose the SLM-F. Do not pull out or remove the spool.

- ② Load the SLM-F following the procedure for SLM-RⅡ given in 5-5-1 above.  
NOTE : Use only the spool that comes with the SLM-F.
- ③ About 2 meters of lead paper are attached to the SLM-F.  
Remove this paper before use.

#### **7 - 5 - 2 “EMPTY” display**

If the master runs out during operation, “EMPTY” will be displayed and the buzzer will sound. In this case, feed the master through to the processor unit making sure that no long slim sections of master remain in the exposure section. Either take out any master from the processor unit by hand, or press the start key after having loaded a new roll of master to discharge any remaining master.

#### **7- 5 - 3 Detecting the master joint**

If a joint connecting two masters together is detected, “ROLL JOINT” is displayed and a buzzer will sound intermittently.

Upon detection of the joint, there are two courses of action.

- ① When the distance (a) from the leading edge of the master to where the joint is detected is less than 265 mm:
  - the master is feed for the distance a plus 285 mm
- ② When the distance (a) from the leading edge of the master to where the joint is detected is more than 265mm:
  - the master is fed for the distance (a)
  - then, the master is fed automatically for 285 mm

## 7-6 Processor Unit

Turn the POWER switch ON. The drive motor will start and the transfer unit rollers will rotate.

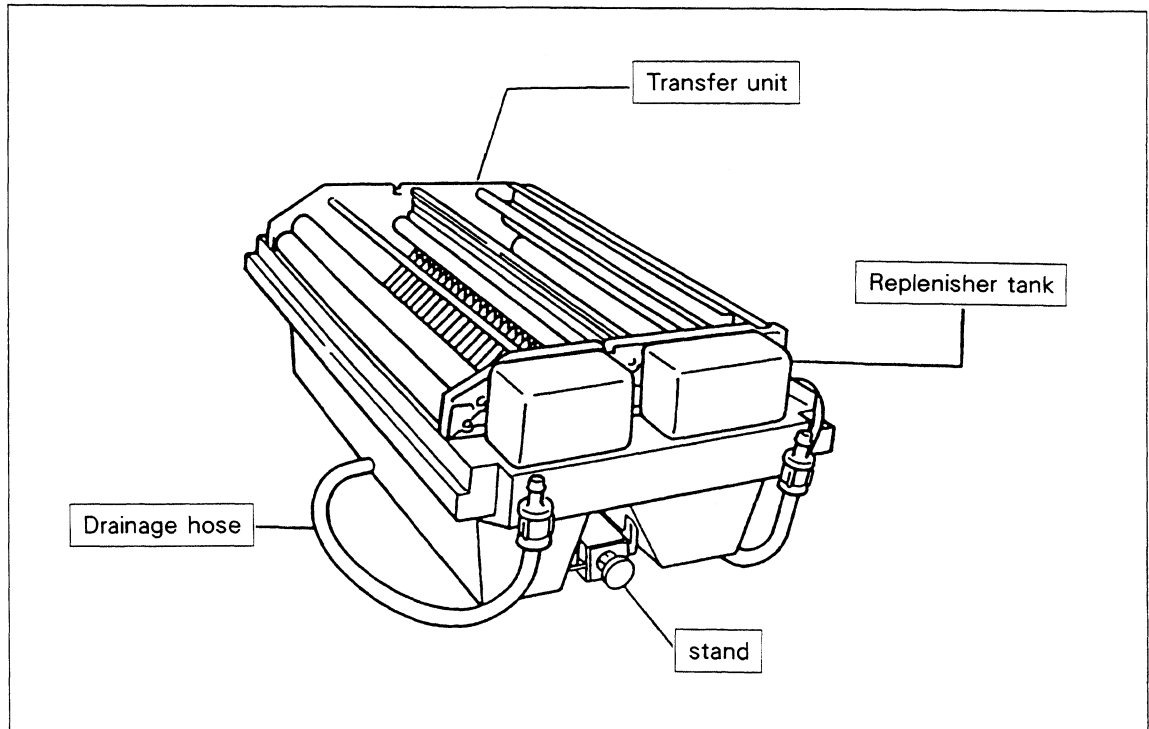

### 7-6-1 Preparing solutions

- Remove the processor unit cover and the securing hook. The processor unit can now be drawn out from the body.
- The processor unit comprises activator and stabilizer tanks, and a transfer unit. A 350W panel heater with built-in thermostat is mounted in the activator tank and maintains the temperature of the activator at about 30°C during operation. When the machine has stood idle for a long time, the rollers in the transfer unit may stick to each other and cause their rotation to become sluggish. In this case, rotate the rollers by hand before starting operation.
- Use the special measuring cup for mixing the processing solutions.
- Use lukewarm water of 30 – 35°C when the water temperature is low, e. g. in winter or cold spells

The action of the activator and stabilizer is reciprocal. Therefore, take care not to allow these two solutions to mix when pouring into the processing tanks.

### 7-6-2 Activator tank (capacity 7 liters)

When the activator (SLM-AC) mixing ratio is 1: 1

- ① Add 3.5 liters of water to 3.5 liters of SLM-AC base solution (exclusive Silver Master activator) , stir well and pour into the activator tank.
- ② Pour 1 liter of activator mixed at a ratio of 1: 1 into the activator replenisher bottle and place on top of the processor unit.

### 7- 6 - 3 Stabilizer tank (capacity 6 liters)

When the stabilizer (SLM-ST) mixing ratio is 1:3

- ① Add 4.5 liters of water to 1.5 liters of SLM-ST base solution (exclusive Silver Master stabilizer) , stir well and pour into the stabilizer tank.
- ② Pour 1 liter of stabilizer mixed at a ratio of 1: 3 into the stabilizer replenisher bottle and place on top of the processor unit.

### 7- 6 - 4 Replenishing solutions

A reasonable amount of replenishing solution mixed at the correct ratio must be maintained at all times. If the replenisher bottles run out of solutions, the level of the solution in the tanks may drop, the solution may become fatigued sooner, and the processing quality may deteriorate.

### 7- 6 - 5 Replacing solutions

See 9.2 General Maintenance

### 7- 6 - 6 Maintaining Solution Levels I

Whenever the solutions in the processor drop below a certain level, a buzzer will ring and the following message will appear on the display:

- ▶ Processing cannot be performed.

REPLENISH  
SOLUTION

#### 【Replenishment Procedures】

1. Turn the buzzer off by pressing the C key.
2. Remove the processor cover and add solution into the tanks.

#### **WARNINGS WHEN HANDLING PROCESSING SOLUTIONS**

- ① Do not drink the solutions. Do not allow the solutions to come in contact with your eyes. (In either case, see a doctor immediately.)
- ② If the solutions have come in contact with your skin by accident, wash off thoroughly with running water.
- ③ Use the solutions correctly in accordance with their method of use.
- ④ Store the solutions in a place out of the reach of children.



## 8. OPERATION

### 8 - 1 Operational Procedure

- ① Turn the POWER switch ON.  
(start-up inspection)

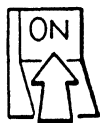

Turn the POWER switch ON to enable operations.

- ② Set the width of the master to be used.

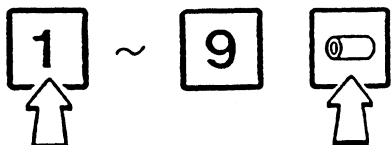

Key in the width of the master in use using the number keys, and press the master width setting key to store to memory.

- ③ Set the LOW/HIGH dryer setting.



Set either HIGH or LOW to suit the drying condition of the master after it has left the processor unit.

- ④ Set the master feed length.

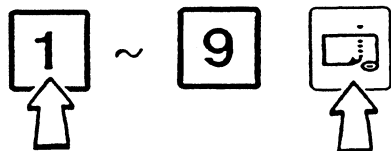

Key in the feed length for the master using the number keys, and press the feed length input key to store to memory.

- ⑤ Set the exposure.

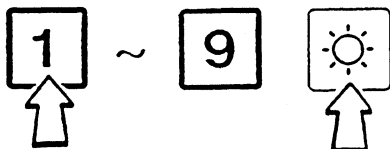

Key in the correct exposure for the copy using the number keys, and press the exposure data input key to store to memory.

- ⑥ Set standard, two-image or multiple exposure.



Using the multiple exposure key, set one of standard, automatic two image exposure or multiple exposure.

- ⑦ Mount the copy.



Place the copy face down on the copy glass at the desired location aligned with the grid lines of the copy positioning sheet.

- ⑧ Turn the start key ON.

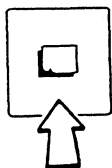

Press the start key when "START OK" is displayed. This starts exposure of the master.

## 8 - 2 How to Calculate the Standard Exposure

As the Silver Master is coated with a silver halide emulsion, its sensitivity varies according to the production lot. When using a Silver Master of differing production lot No., check its sensitivity before exposure. Under-exposure will result in a thickened image or scumming on the background of the plate. Over-exposure may cause too thin an image or lost image.

The performance of high-quality Silver Master R II and Silver Master F can be fully put to use by correctly adjusting the exposure

Also see the Silver Master Technical Guide supplied separately.

① The CP-414S comes with a test chart and standard exposure samples. Using the procedure in 8.1, reproduce the test chart and compare it with the exposure samples to find the correct exposure.

② Judge the gray scale of the reproduced test chart, adjust the exposure and set as the standard exposure.

Standard exposure: the exposure where the minimum noticeable silver deposit is seen in the 12th step with a wedge as in the supplied sample.

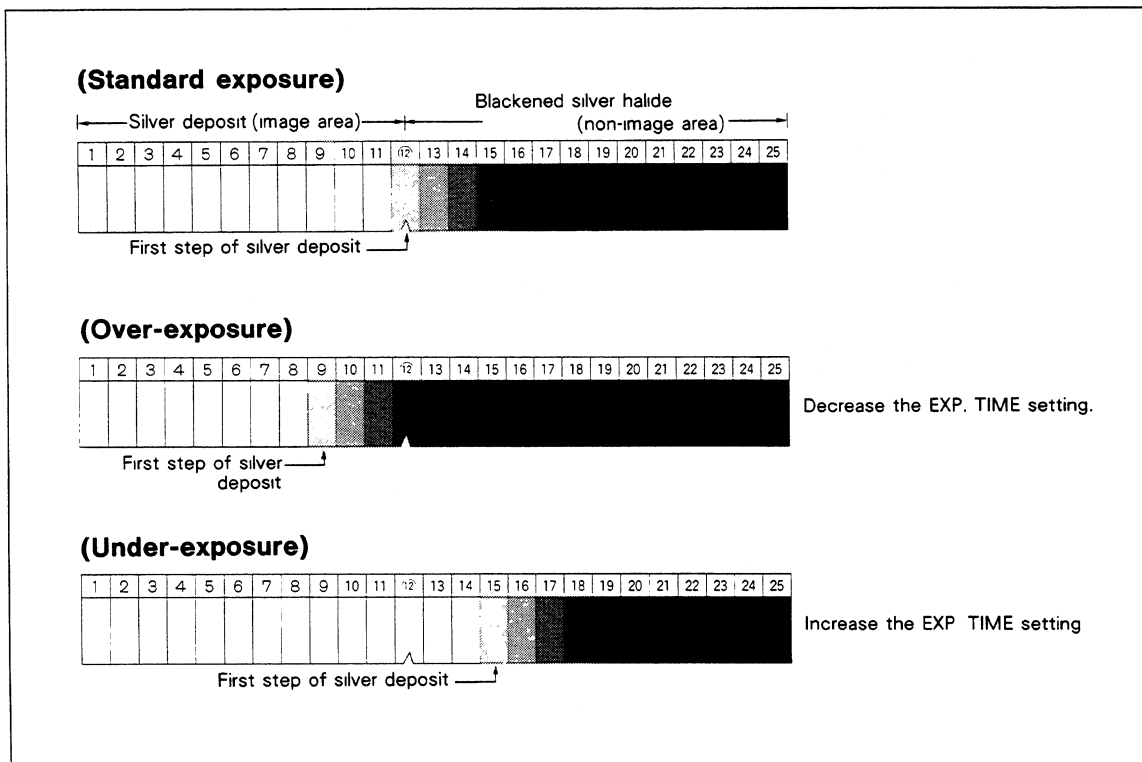

NOTE . The standard exposure samples may fade if stored for a long time. Store in a darkroom draw, etc. .

### 8 - 3 How to Calculate the Exposure for Specific Jobs

- ① The correct exposure varies according to the type of the copy from which the master is to be made.
- ② Although the correct exposure for each type of copy varies according to various printing conditions (printing press, type of paper, ink, etc. ) , the table below should serve as a basic guide. Otherwise, find the correct exposure from data provided by various printing shops.

Reference:

The table below shows the correct exposure for various types of original. The values given in the correct exposure column are percentage values with respect to the standard exposure.

Copy		Correct Exposure
Condition	Type	
Faint, or lowdensity line or image	Pencil handwriting	0 to - 20% Decrease exposure so that non-image areas are not reproduced whitish.
	Duplicate	
Copy with blurred text or with blackish background	Photocomposition	-10 to + 20%
	Type	0 to + 30% (increase exposure)
	Halftone	+20 to + 30% (increase exposure)









## 9. MAINTENANCE

Carry out the following items every day so as to use the functions of the machine to the maximum and to maintain the machine in an optimum state.

### 9- 1 Maintenance Mode

The maintenance mode is used for checking operations and for carrying out general maintenance.

\* The maintenance mode can be entered when "STAND BY" is displayed.

	Item	Key Operation	Purpose and Operation
1	Independent operation of cutter	 +  Press 1 while pressing count key.	★ To check cutter operation. <ul style="list-style-type: none"> <li>• Cutter moves forward (cutting direction) , and returns to its origin after reaching inversion sensor.</li> </ul>
2	Independent operation of copy table NOTE : First set nip roller to ( 8 ) .	 +  Press 2 while pressing count key. Turn the power switch off.   +  Turn the power back on. Then press the "4" key while holding down the count key	★ 1. To clean copy glass <ul style="list-style-type: none"> <li>• Copy table moves to left and stops at end point sensor.</li> <li>• Copy table moves right to return to origin. If it has not contacted end point sensor, resetting machine returns copy table to origin.</li> </ul>
3	Independent lighting of halogen lamp light source	 +  Turn the power back on. Press 3 while pressing count key.	★ To check lighting of halogen lamp light source <ul style="list-style-type: none"> <li>• Lamp lights for 5 seconds and goes out automatically.</li> </ul>

## 9-2 General Maintenance

### 9-2-1 Processor unit

- ① Replacement cycle for processing solutions
- ② Cleaning the processing tanks and unit

As masters are processed, dissolved silver, paper particles and chemicals adhere to the tanks and transfer unit causing them to become dirty.

Clean these parts when replacing the processing solutions.

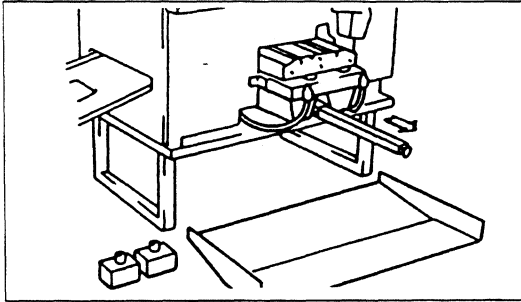

- ① Turn the POWER switch OFF.
- ② Remove the front panel of the body and pull the processor unit out slightly.
- ③ Pull the stand out in the direction of the arrow and set it aside

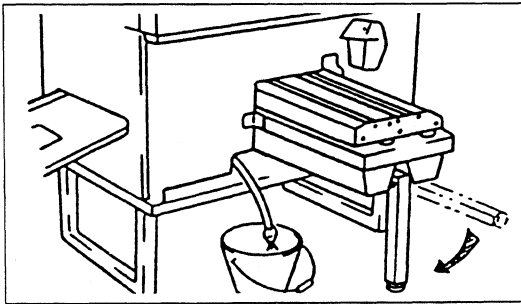

- ④ Remove the replenishment tanks.
- ⑤ Prepare a bucket, etc. for draining the solutions and place the drainage hose into the bucket.
- ⑥ When all the waste solution has been drained off, restore the drainage hose to its original position.

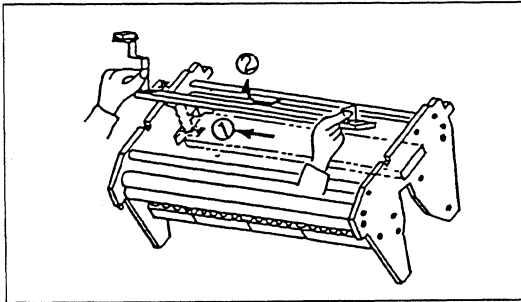

- ⑦ Remove connector #J8.
- ⑧ Completely pull out the processor unit and carry to a location where cleaning work can easily be carried out.
- ⑨ Remove the transfer unit from the tanks. Then carefully remove the anti-oxidation panel.

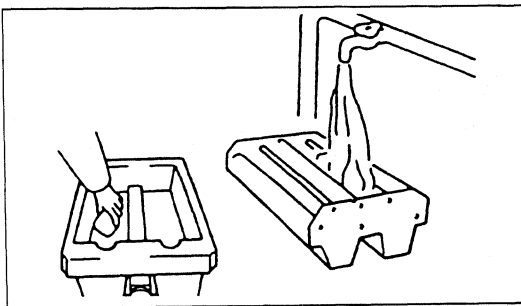



- ⑩ Wash the tanks and transfer unit well. Wipe off all scum attached to the rollers, tanks sides, etc. with a mistened cloth or sponge.

NOTE : As the rubber parts used in the rollers of the transfer unit are susceptible to heat, wash and rinse with water of 40°C or less. Do not use detergent or polishing sand.

### 9 - 2 - 2 Replacing the cutter knife

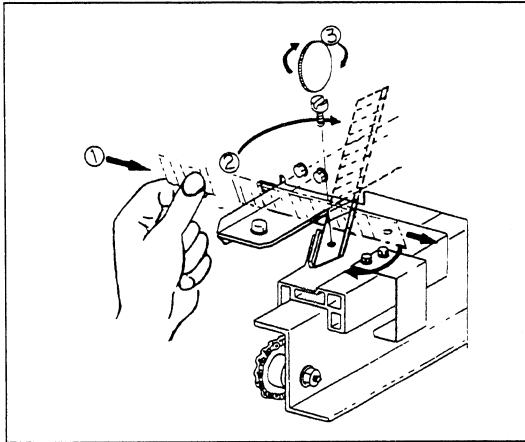
A single cutter knife is good for 300 masters (or about two) . Or replace after every 30 days of use regardless of the number of masters it has cut.



- ① Turn the POWER switch OFF.
- ② Remove the front panel.
- ③ Remove the cutter cover.
- ④ Insert the cutter knife into the cutter knife guide and affix in the prescribed position.
  - ★ Take care of the sharp cutting edge.
  - ★ Use a commercially available NT cutter with an 85 mm long cutting blade.
  - ★ Align the back of the blade with the cutter carriage guide and tighten the fastening screw.
- ⑤ Turn the POWER switch ON.
- ⑥ Set the machine to standby and check cutter movement.  + 
- ⑦ Cancel the standby state.

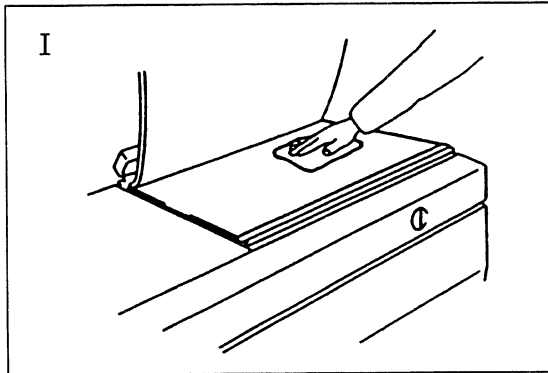

### 9 - 2 - 3 Copy glass

As the copy glass plate is liable to be stained by dust or fingermarks, never fail to carry out a daily start-up check. If stained, wipe it with a soft cloth using a glass cleaner (available on the market) , taking care not to leave any cleaning agent behind.



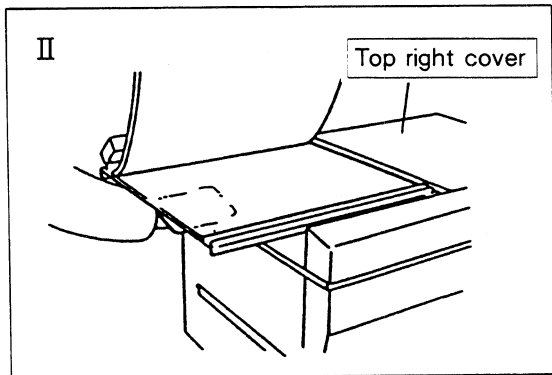

- ① Open the copy cover to clean the upper side of the glass plate.

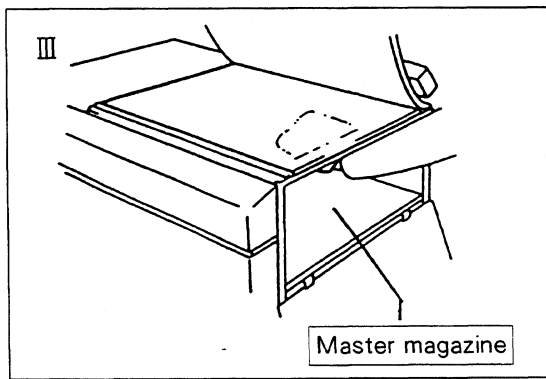

- ② To clean the left underside of the glass plate, move it to the left while the machine is on STAND BY using the following key operation sequence :  +  + 
- ③ Remove the top right cover and then take out the partition (removable) in the direction of the arrow.  
(See Fig. IV. )



- ④ Turn the power off and then back on. To clean the right underside of the glass plate, move it to the right with the machine on STAND BY using the following key operation sequence :  +  + 

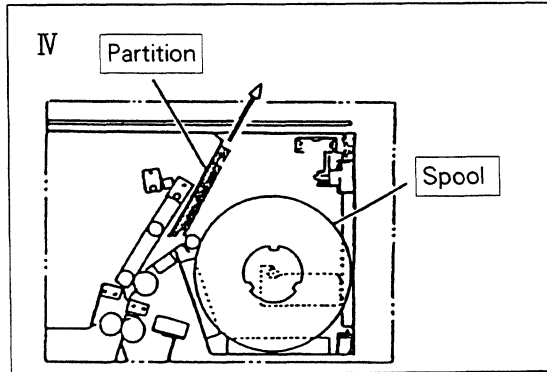

- ⑤ Move the copy glass plate to the left and replace the partition and top right cover.

#### 9 - 2 - 4 Lens and mirrors

The lens and mirrors are located internally and rarely become dirty.

However, When used for a long time, dust, etc. in the room may cause the functions of the optical system to decrease.

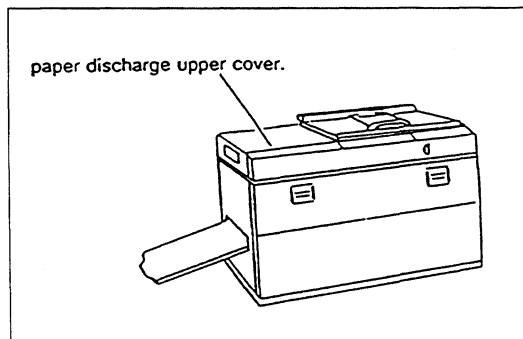

- ① Turn the POWER switch OFF.  
② Remove the paper discharge upper cover.

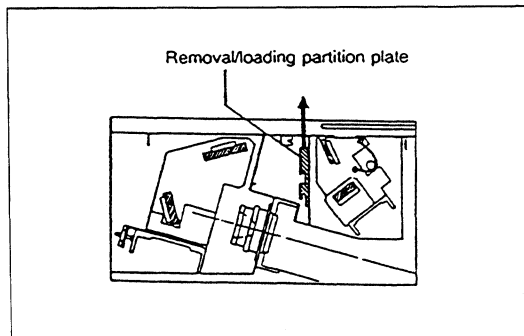

- ③ Remove the removal/loading partition plate in the direction the arrow.

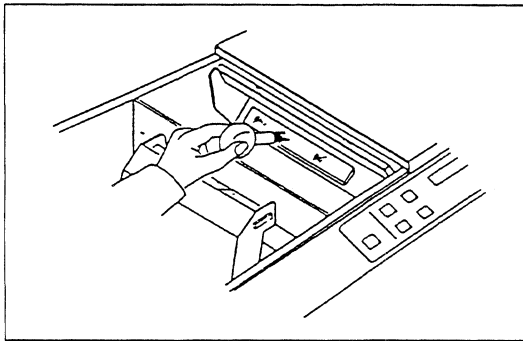

- ④ Clean mirror ① using an air brush.
  - ▶ If very dirty, wipe clean with lens tissue moistened with a small amount of commercially available alcohol. Lens tissue can be purchased at any camera store.

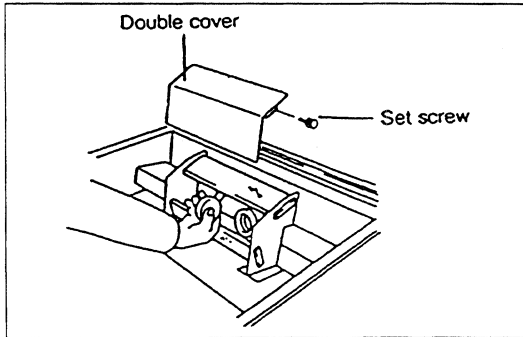

- ⑤ Remove the double mirror cover and clean mirrors ② and ③

### 9 - 2 - 5 Cleaning the dryer's feed roller

Dirt on dryer rollers may scratch the master or be transferred to the emulsion side of the master.

- ▶ Clean the rollers when replacing the master plate.

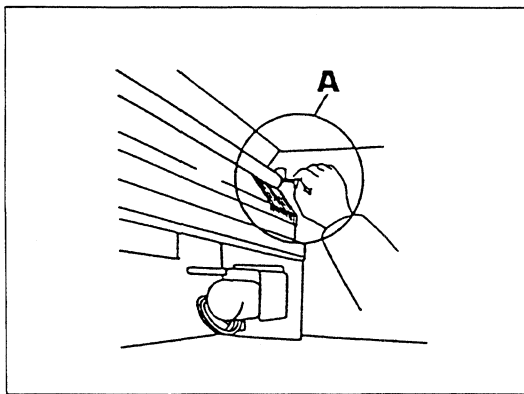

- ① Turn the POWER switch OFF.
- ② Remove the processor cover and remove the processor body.
- ③ Remove the tension leaf spring at the upper dryer feed roller from the set screw in the direction of the roller.

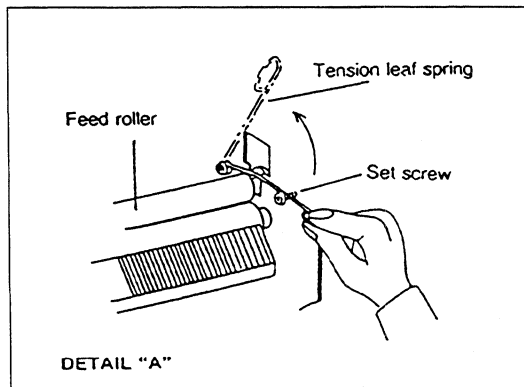

- ④ Remove the upper roller, and wipe off any dirt from the squeegee roller using a moistened cloth.
- ⑤ Restore the roller to its original position and hook on the tension leaf spring.
- ⑥ Attach the processor body and front cover.







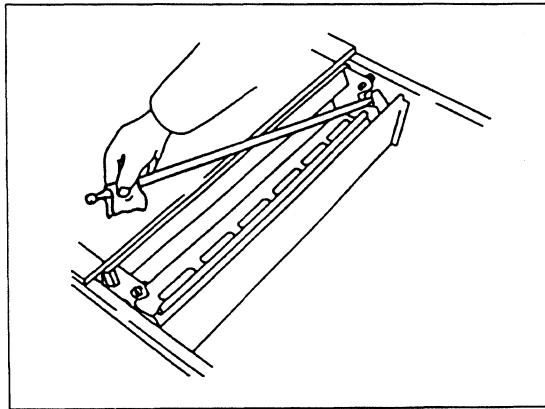
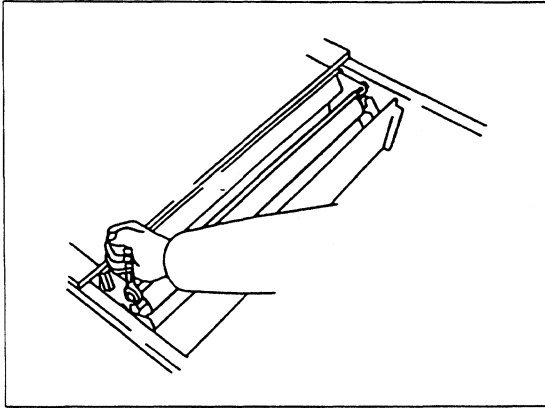

### 9 - 2 - 6 Replacing the halogen lamp

The machine uses a 80V, 800W halogen lamp as the light source.

Prior to replacing the lamp with a new one, never fail to make sure that the lamp and the reflector have cooled.



- ① Turn the nip roller lever to ( "free" position) .
- ② Set the "STAND BY" mode and move the copy holder to the left. (Press  +  .)
- ③ Turn off the power switch.
- ④ Unscrew (M4 × 4) and remove the top cover at the master magazine side.  
Remove the reflector fastening screws (M4 × 2) .
- ⑤ Hold the lamp with a clean dry cloth or in your gloved hands.  
Never hold it with bare hands.  
Take care not to smear or fingerprint the lamp surface.  
Such stains could cause an uneven illumination. If the lamp should be fingerprinted or smeared, apply a very small amount of commercial alcohol to lens paper (available at general camera shops) and lightly wipe with the lens paper.
- ⑥ After the lamp has been replaced, turn on the main switch.
- ⑦ Set the STAND BY mode and check to see if the new lamp lights up normally.  
(Press  +  .) The lamp should light for 5 sec.
- ⑧ Return the reflector to the original position and replace the top cover as it was.
- ⑨ Return the copy holder to the original position.  
(Press  +  .)
- ⑩ Cancel the STAND BY mode.

# 10 . TROUBLE SHOOTING

## 10 - 1 Error Messages

If an error message appears, it means that the machine is in trouble. Turn off the main switch, allow at least 5 seconds, then turn it back on, and retry operation. If the machine still does not work normally, contact us.

Display	Error	Check Point
ERR1	Although the cutter moves forward (in cutting direction) and touches sensor, it does not stop by the sensor, but turns back to the original position by mechanical collision.	<ul style="list-style-type: none"> <li>① Cutter return sensor PS6 is defective. Replace it.</li> <li>② Check for a connector contact defect or discontinuity.</li> </ul>
ERR2	After cutting, although the cutter returns, it stops not because the original position sensor works but because the motor stops running.	<ul style="list-style-type: none"> <li>① Cutter original position sensor PS5 is defective. Replace it.</li> <li>② Check for a connector contact defect or discontinuity.</li> </ul>
ERR3	Upon pressing,  the copy holder moves but stops not at the prescribed position but at end sensor PS4.	<ul style="list-style-type: none"> <li>① Master feed sensor PS2 is defective. Replace it.</li> <li>② Check for a connector contact defect or discontinuity.</li> <li>③ The encoder on the left as viewed from the machine rear (non-operation) side is not in place, or is rotating abnormally.</li> </ul>
ERR4	In auto double exposure, after the 1st exposure, the copy holder should return to a position which differs depending on the input master and copy lengths. If the holder fails to complete the return within a specified time period, it stops.	<ul style="list-style-type: none"> <li>① Copy holder return sensor PS1 is defective. Replace it.</li> <li>② Check for a connector contact defect or discontinuity.</li> <li>③ The encoder in the middle as viewed from the machine rear (non-operation) side is not in place, or is rotating abnormally.</li> </ul>

## 10 - 2 Cutter Malfunction

If the material is delivered uncut, the following message appears on the display. Check the points stated below.

Display	Error	Check Point
CHK CUTTER	The exposed material comes out of the machine without being cut.	<ul style="list-style-type: none"> <li>① Check for a broken blade.</li> <li>② Do the check as outlined in 10. 1 for ERR2.</li> </ul>

NOTE : For cutter blade replacement, refer to 9 - 2 - 2.

# 11 . OPTIONAL EQUIPMENT

## Automatic replenishment device

This device automatically replenishes the replenishment fluid to support the processing ability of the fixer for long periods.

### 11 . 1 Part names

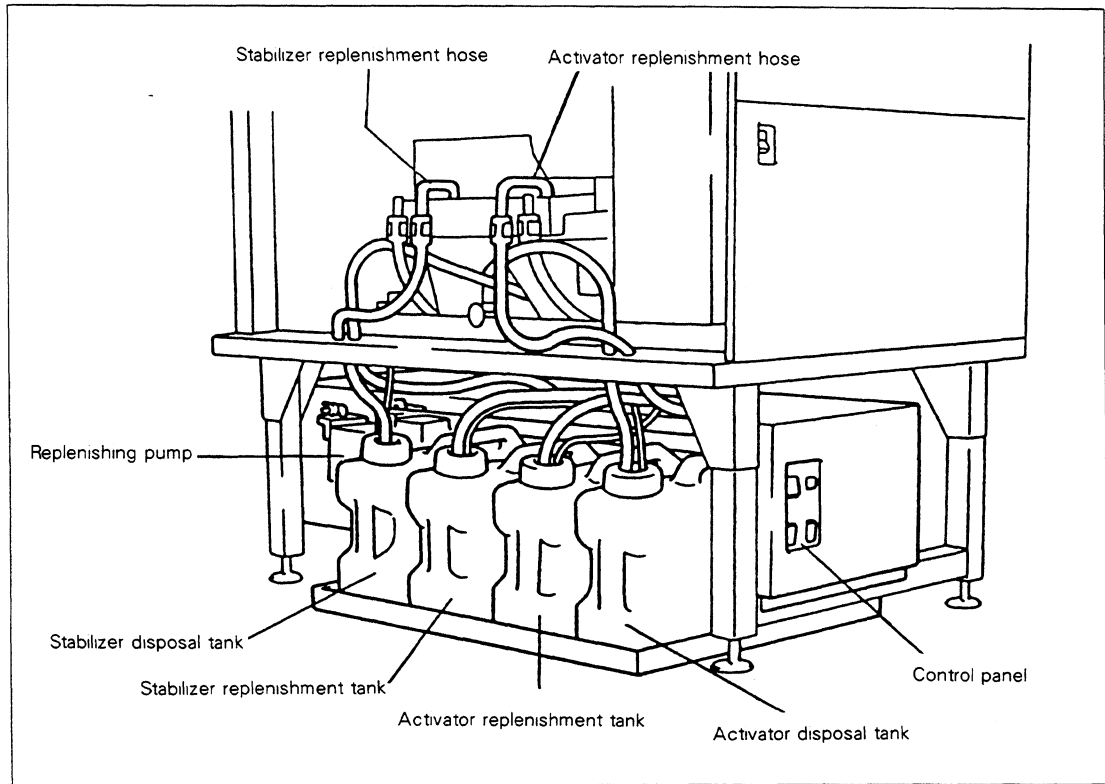

- ① Activator replenishment hose
- ② Stabilizer replenishment hose
- ③ Replenishing pump
- ④ Stabilizer disposal tank
- ⑤ Stabilizer replenishment tank
- ⑥ Activator replenishment tank
- ⑦ Activator disposal tank
- ⑧ Control panel

## 11 - 2 Explanation of the control panel

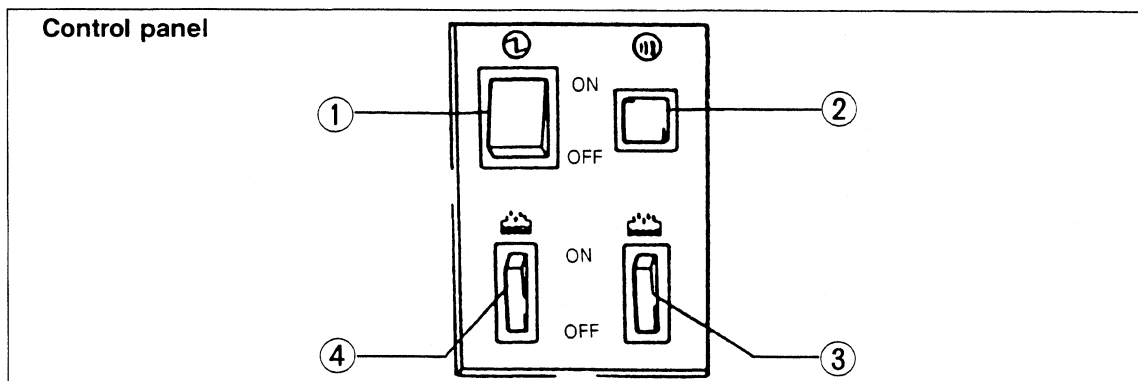

- ① **Sub switch**  
When this is switched ON, power is supplied to the control circuit and replenishment becomes possible.
- ② **Buzzer cut switch**  
The buzzer sounds when the sensors in the replenishment or disposal tanks operate. Pressing the buzzer cut switch stops the buzzer.
- ③ **Manual switch for activator replenishment**  
When this switch is ON the activator is replenished.
- ④ **Manual switch for stabilizer replenishment**  
When this switch is ON the stabilizer is replenished.

## 11 - 3 Making and changing replenishment settings



### 11 - 3 - 1 Automatic replenishment mode

When the overall operating area, from the established master width and master operating length, reaches 1m<sup>2</sup>, replenishment is approximately 50cc/cycle. The standard time between replenishment cycles is seven minutes.

Note · Replenishment takes place after the master is completely immersed in the developer vat, so the start key is ineffective when the display shows the following:

- "REPL IN WAITING"

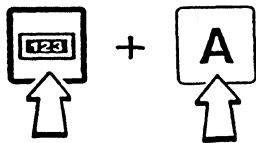
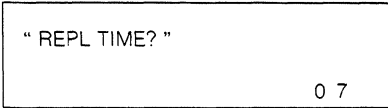

The standard replenishment cycle time is set at seven minutes. When you wish to alter this value please follow the procedure outlined below.

<p>1) While pressing the count key, press the auto key.</p> 
<p>2) "REPL TIME" and the currently input value "07" are displayed.</p> 
<p>3) Input the desired value using the number keys, the example shows a value of 8 seconds</p> 
<p>4) Input this value by pressing the count key.</p> 

### 11 - 3 - 2 Startup Replenishment Mode

When the processor is not used for an extended period of time, chemicals in the processor tanks will gradually be depleted through evaporation and oxidation. You can preset the unit to automatically replenish solutions after the unit is started up, thereby ensuring stable processing quality.

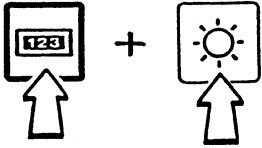
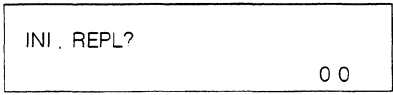
**Set or alter the startup replenishment time as follows.**

<p>1) While pressing the count key, press the exposure data key.</p> 
<p>2) "INI. REPL" and the startup value "00" are displayed.</p> 
<p>3) Input the desired value using the number key, the example shows a value of 5 seconds.</p> 
<p>4) Input this value by pressing the count key.</p> 

## 11 - 4 Maintaning Solution Levels II

When the level of the processing solution in the tanks drops below a certain level, automatic replenishment will begin and the following display will appear.

- ▶ Processing cannot be performed during replenishment.

REPL IN WAITING	0 0
--------------------	-----

If the level of the solution does not rise during replenishment, the unit will stop operation, alert the operator via buzzer sound, and display the following:

CHECK PROCESSOR	0 0
--------------------	-----

### 【 Checking procedures 】

1. Remove the processor cover.
2. Pull the tank forward and check to ensure that the anti-oxidation panel is free to move up and down, and that the hoses are corrected and untangled.
3. Replace the processor cover and check to see if replenishment is reactivated

★ If problems remain, contact an authorized service office.

# 12. WIRING DIAGRAMS

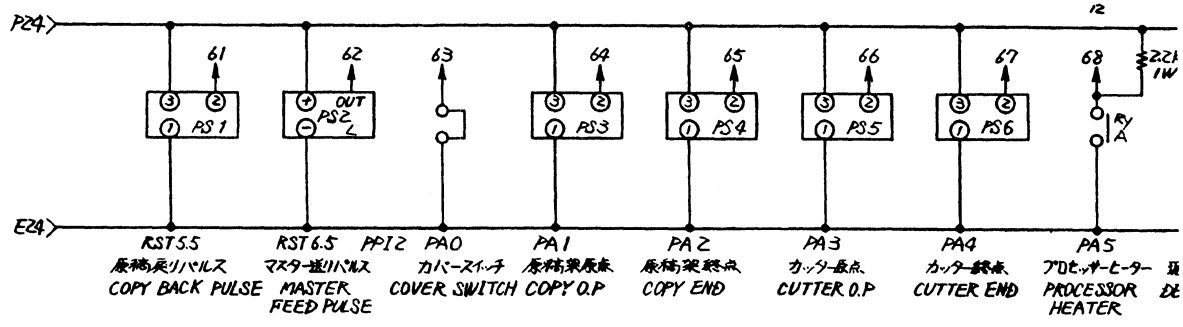
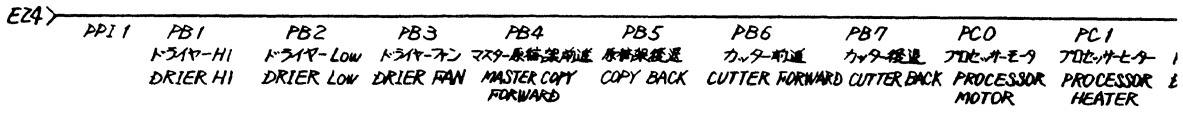
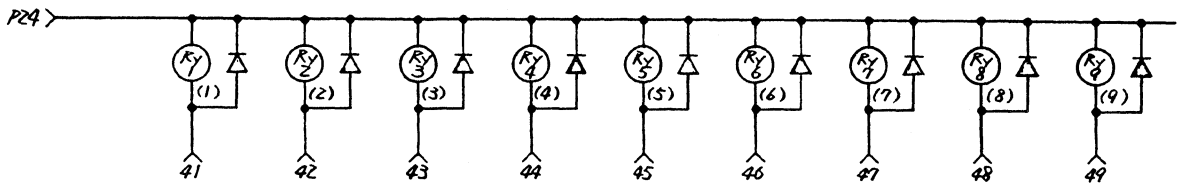
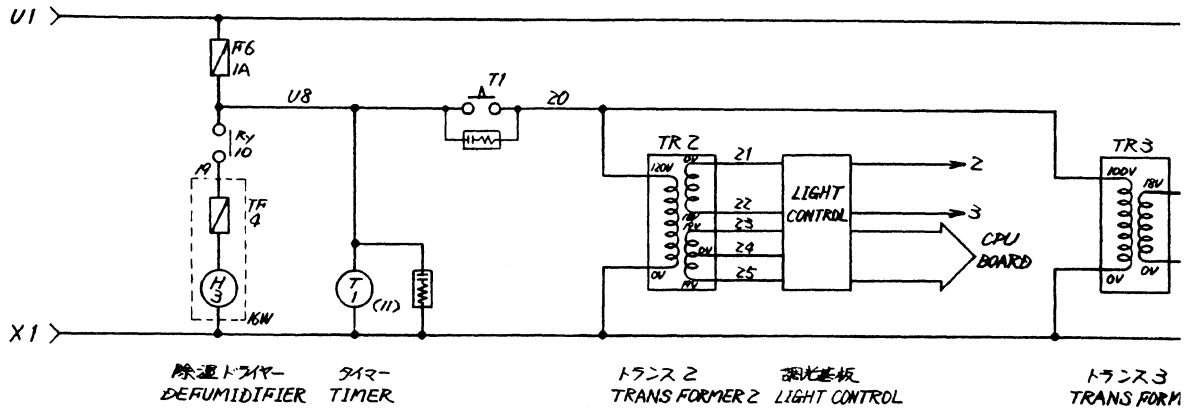
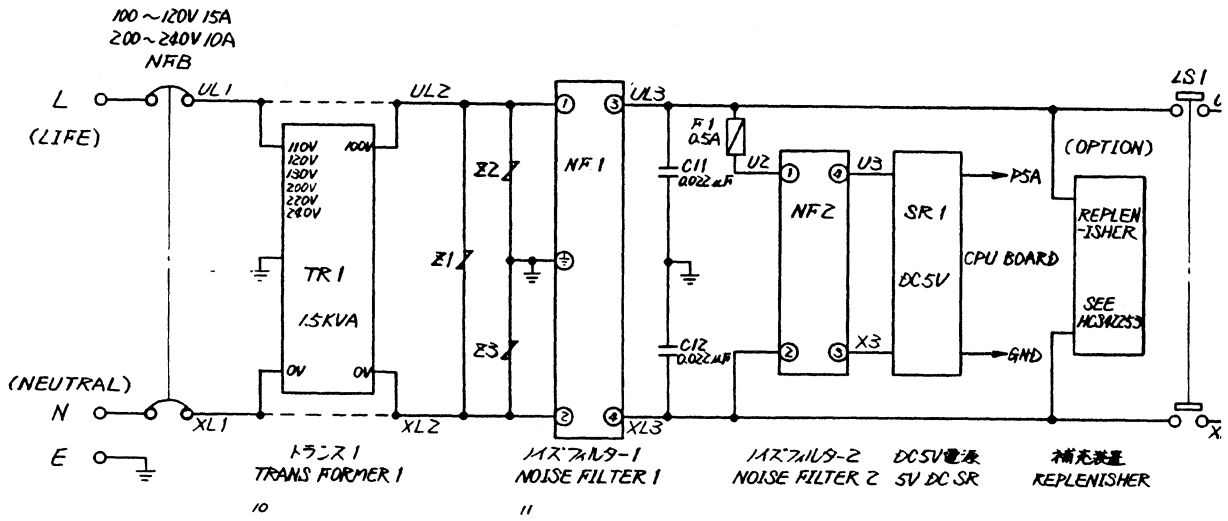



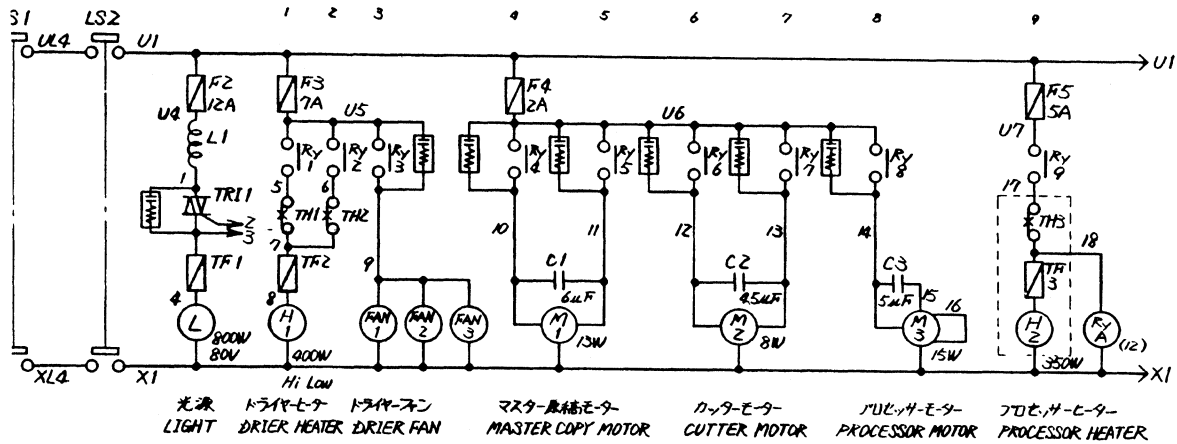

○U1

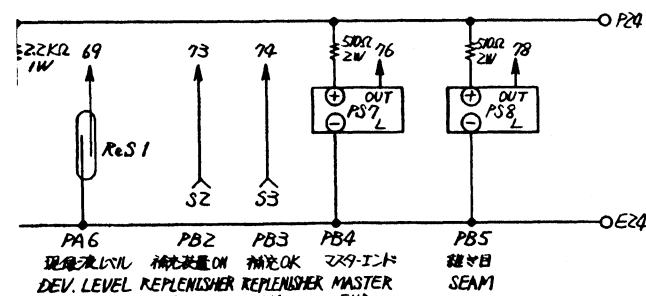
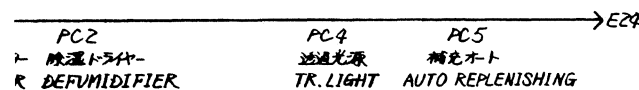
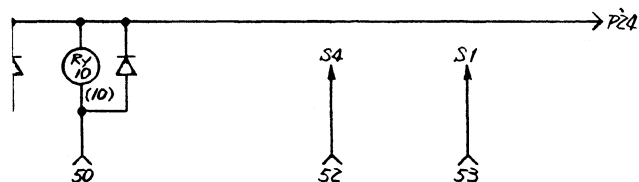
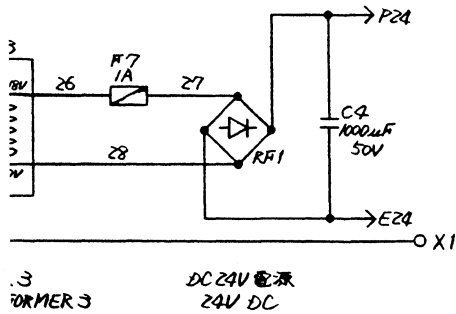

補充装置  
REPLENISHER

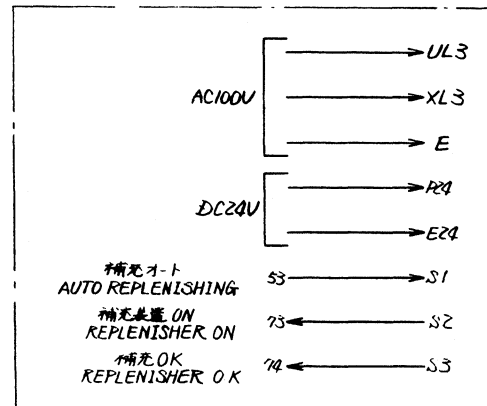

透過光源  
TR. LIGHT

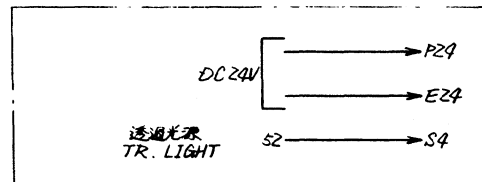

WIRING SYSTEM DIA.

DWG NO. HCS32323

CN1, CN23

PIN NO.	WIRE NO.	PIN NO.	WIRE NO.
1	P5	2	P5
3	P5	4	P5
5	3C8	6	3C1
7	3C2	8	3C3
9	3C4	10	3C5
11	3C6	12	3C7
13	3A8	14	3A1
15	3AZ	16	3A3
17	3A4	18	3A5
19	3A6	20	3A7
21	3B8	22	3B1
23	3B2	24	3B3
25	3B4	26	3B5
27	3B6	28	3B7
29	T7	30	
31	GND	32	GND
33	GND	34	GND

CN NO.	1	2	3
	WIRE NO.	WIRE NO.	WIRE NO.
CN2	PSA	GND	
CN5	E24	61	P24
CN6	E24	62	P24
CN7	E24	63	
CN8	E24	64	P24
CN9	E24	65	P24
CN10	E24	66	P24
CN11	E24	67	P24
CN12	E24	68	P24
CN13	E24	69	
CN17		73	
CN18		74	
CN19	E24	76	75
CN20	E24	78	77

E24-63 SHORT 23.86

CN3

PIN NO.	WIRE NO.	PIN NO.	WIRE NO.
1	PSB	2	1A8
3	1A1	4	1A2
5	1A3	6	1A4
7	1A5	8	1A6
9	1A7	10	1B8

CN2

PIN NO.	WIRE NO.	PIN NO.	WIRE NO.
1	P24	2	P24
3	P24	4	E24
5	E24	6	E24
7	41	8	42
9	43	10	44
11	45	12	46
13	47	14	48
15	49	16	50
17	51	18	52
19	53	20	

(表1)

CPUCN NO.	行	先
CN 1	→	CONTROL PANEL CN23
CN 2	→	SWITCHING REGULATOR SR1
CN 3	→	LIGHT CONTROL BOARD CN83
CN 4	→	RELAY BOARD CN30
CN 5	→	COPY BACK PULSE SENSOR PS1
CN 6	→	MASTER FEED PULSE SENSOR PS2
CN 8	→	COPY O.P. SENSOR PS3
CN 9	→	COPY END SENSOR PS4
CN 10	→	CUTTER O.P. SENSOR PS5
CN 11	→	CUTTER END SENSOR PS6
CN 12	→	RELAY BOARD CN33
CN 13	→	DEV. LEVEL SW ReS1 J7
CN 17	→	REPLENISHER J1
CN 18	→	REPLENISHER J1
CN 19	→	MASTER END SENSOR PS7
CN 20	→	MASTER FEED PULSE SENSOR PS8

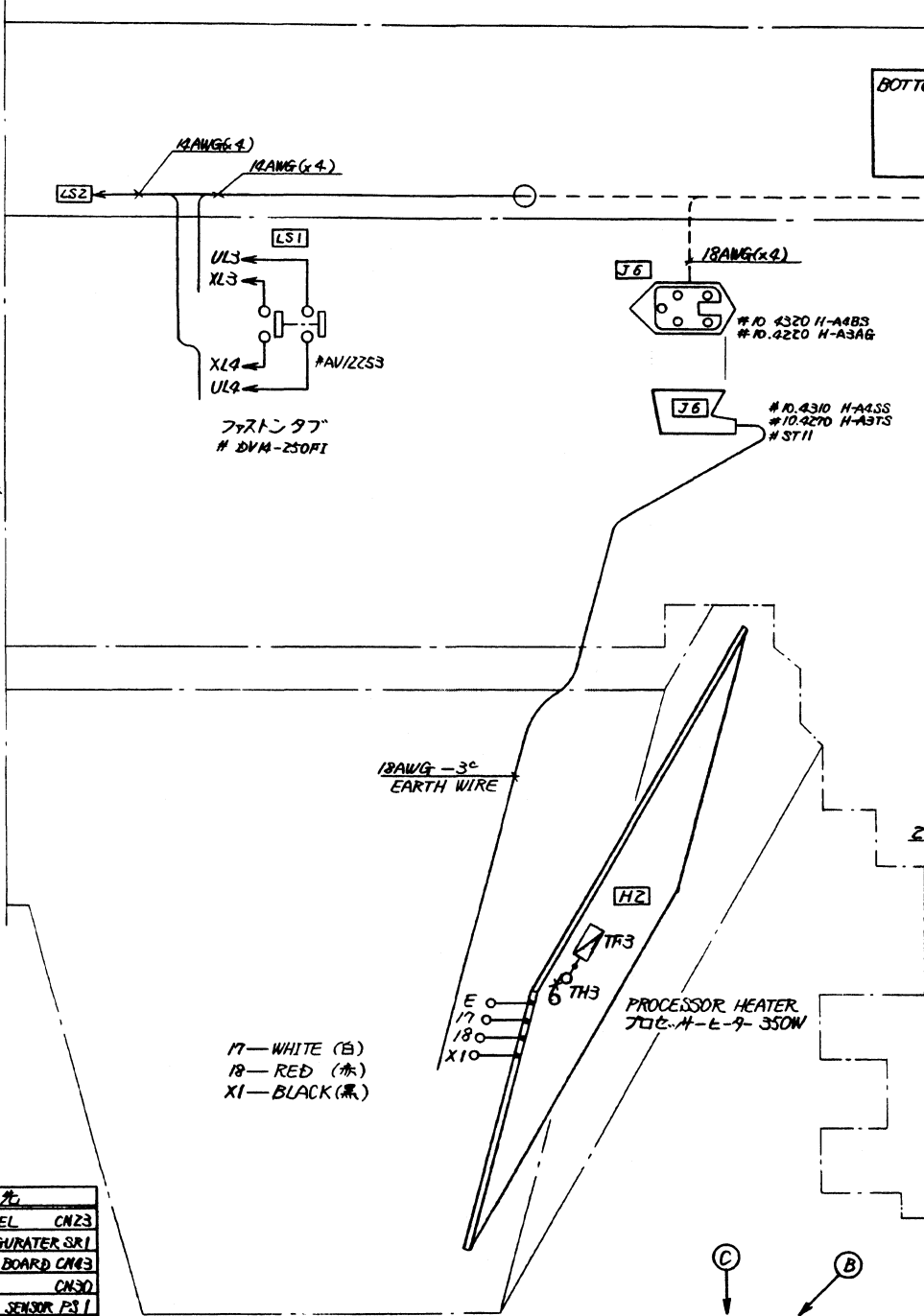

Ⓐ	DISTRIBUTING BOARD CONNECTION DIA 配電盤結線図	HCM 31263
Ⓑ	BACK VIEW CONNECTION DIA 後面結線図	HCE 31653
Ⓒ	TOP VIEW CONNECTION DIA 上部結線図	HCF 31652
	WIRING SYSTEM DIA 系統図	HCS 32323

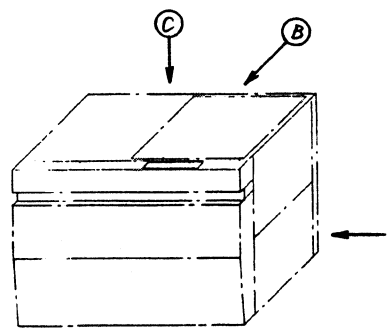

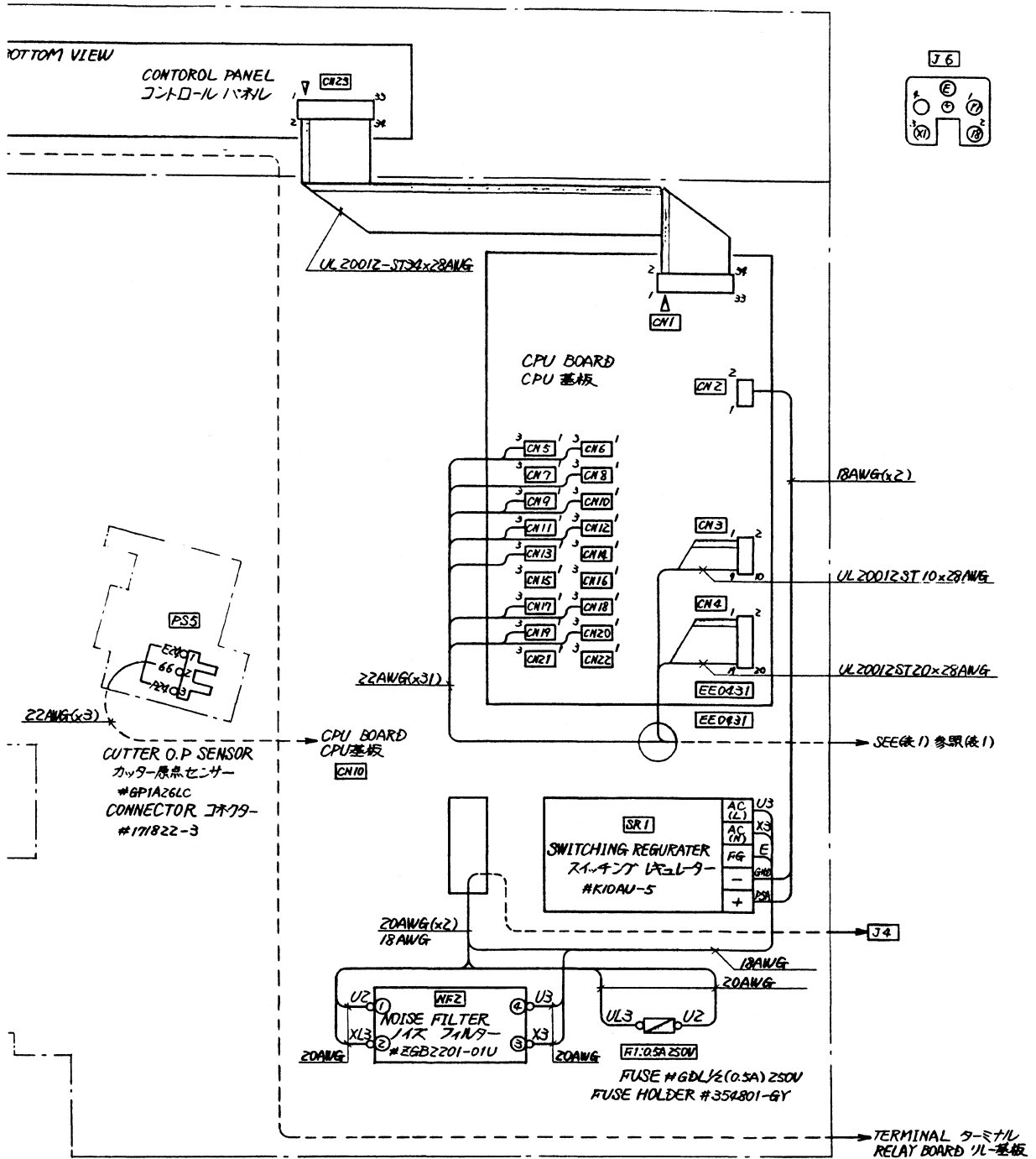

※ HEAT PROOF WIRE — UL1727 TETRAFLUOROETHYLENE WIRE (耐熱線) (テフロン電線)  
 14~18 AWG UL1015 105°C 600V  
 20~21 AWG UL1007 80°C 300V

①

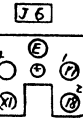

WIRING DIA.

DWG NO. HCW31879

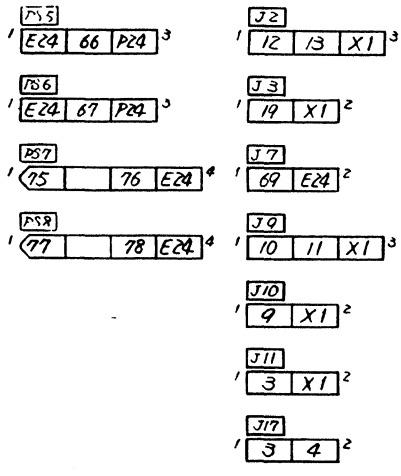

200V~240V VDE ES-302-250  
 100V~120V MAWG(x3)  
 MAWG(x2)

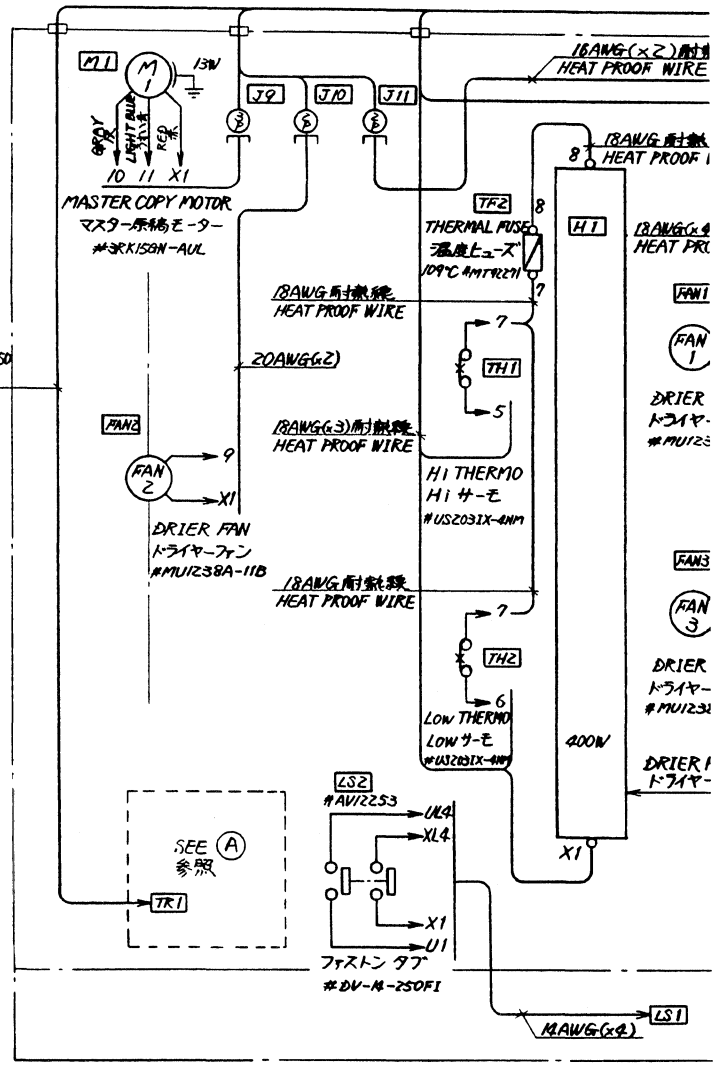

CN NO コネクタ NO.	RELAY BOARD CN NO リレー基板コネクタ NO.
J 2	→ CN 40
J 3	→ CN 40
J 7	→ CPU基板 CN 13
J 9	→ CN 39
J 10	→ CN 37
J 11	→ CN 36
J 12	→ CN 37
J 13	→ CN 37
J 15	→ CN 37

SENSOR NO センサー NO.	CPU BOARD CN NO CPU基板コネクタ NO.
PS 5	→ CN 10
PS 6	→ CN 11
PS 7	→ CN 19
PS 8	→ CN 20

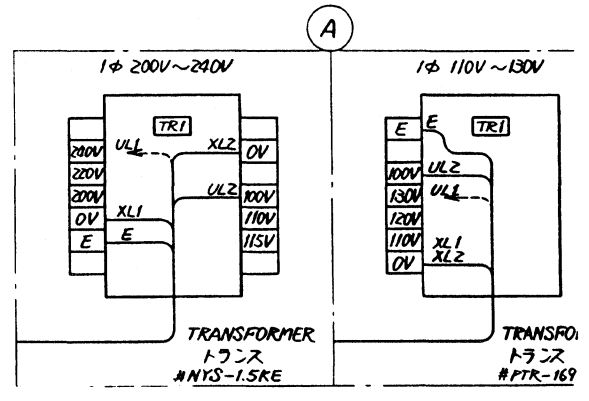

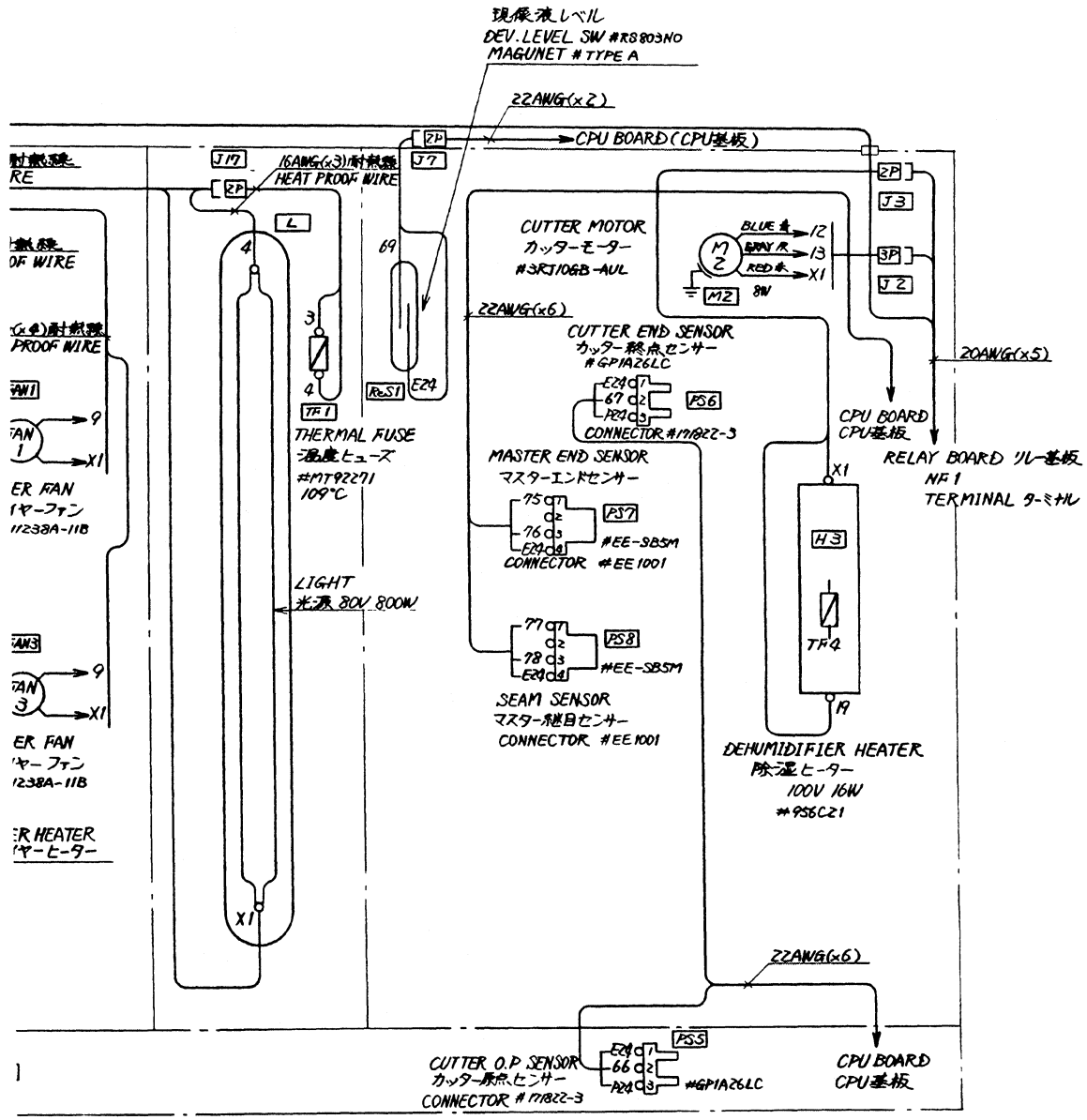

※ 14~18AWG — UL1015 105°C 600V  
 20~24AWG — UL1007 80°C 300V  
 HEAT PROOF WIRE — UL1727 TETRAFLUOROETHYLENE WIRE  
 (耐熱線) (テフロン電線)

FORMER  
 ス  
 169

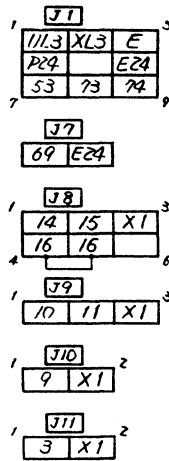
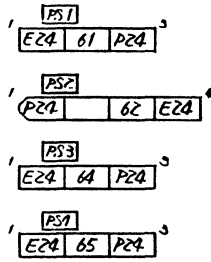

※ 順番16の波1個置き  
×2側にて行なす。

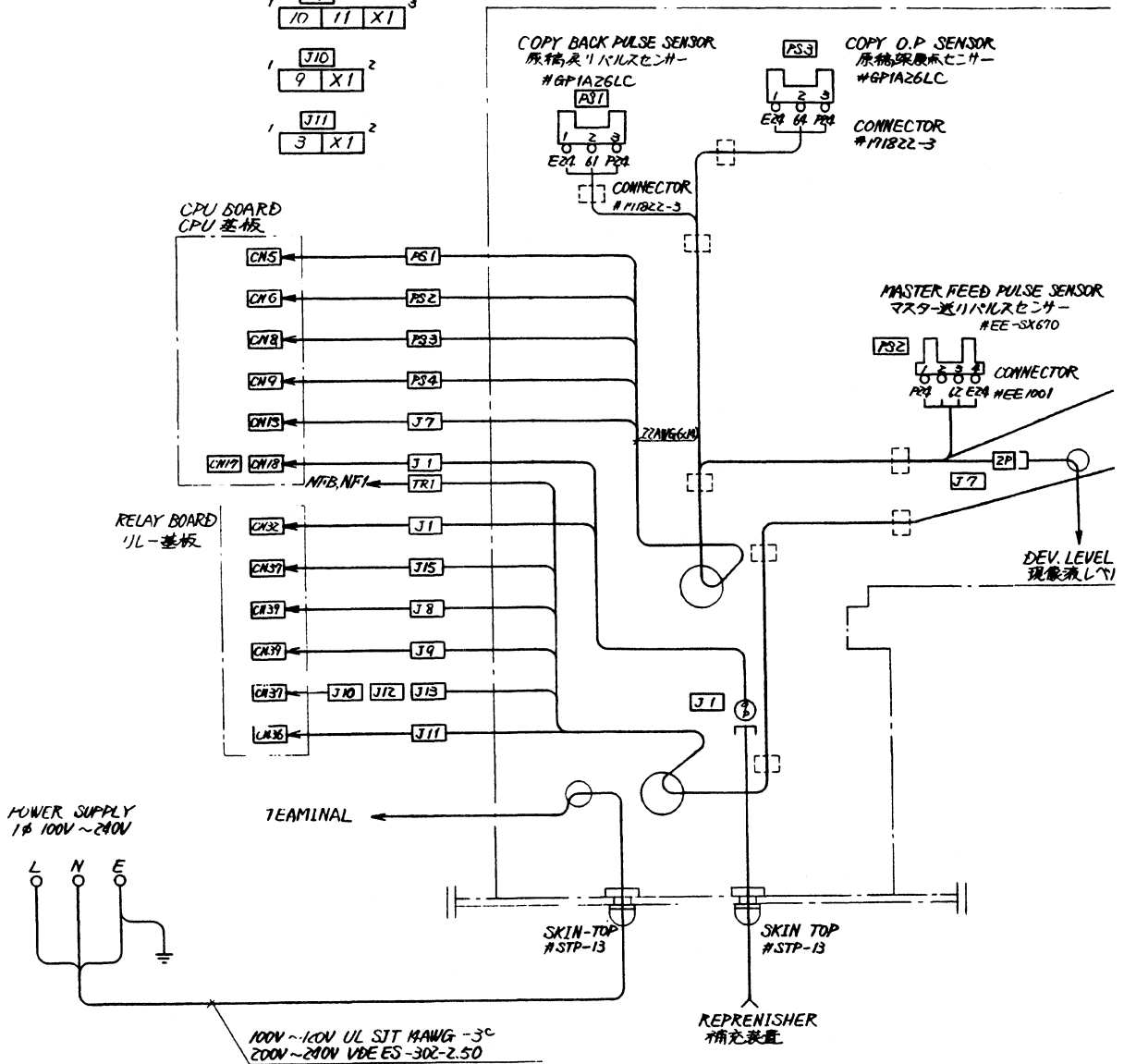
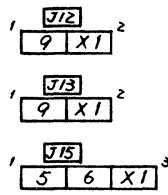

--- #TA1S8

※ 14~18AWG UL  
20~24AWG UL  
HEAT PROOF W/1  
(耐熱線)

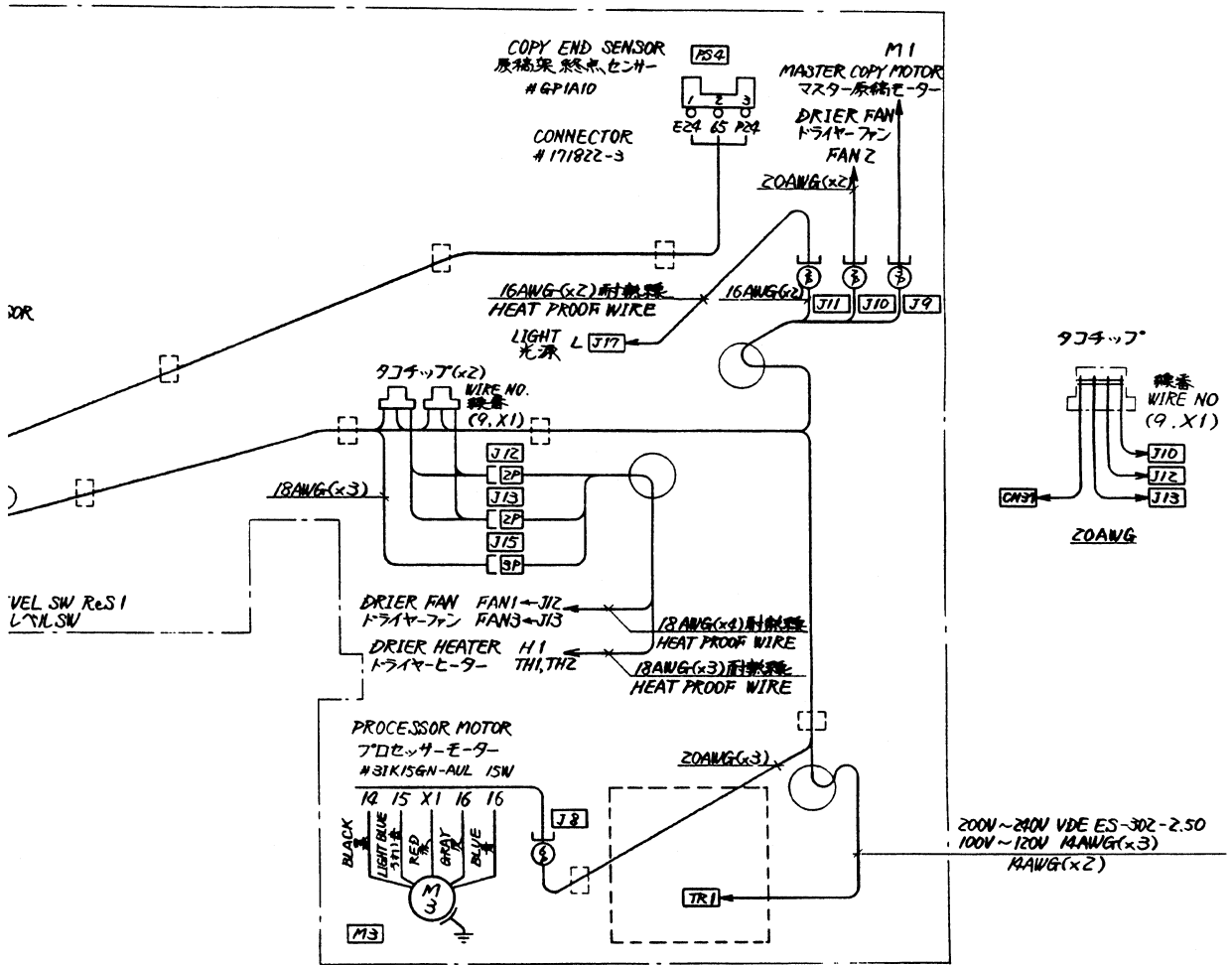

UL1015 105°C 600V  
 UL1007 80°C 300V  
 WIRE—UL1121 TETRAFLUOROETHYLENE WIRE  
 (フロン電線)

BACK VIEW  
 CONNECTION DIA.  
 DWG NO. HCZ31653

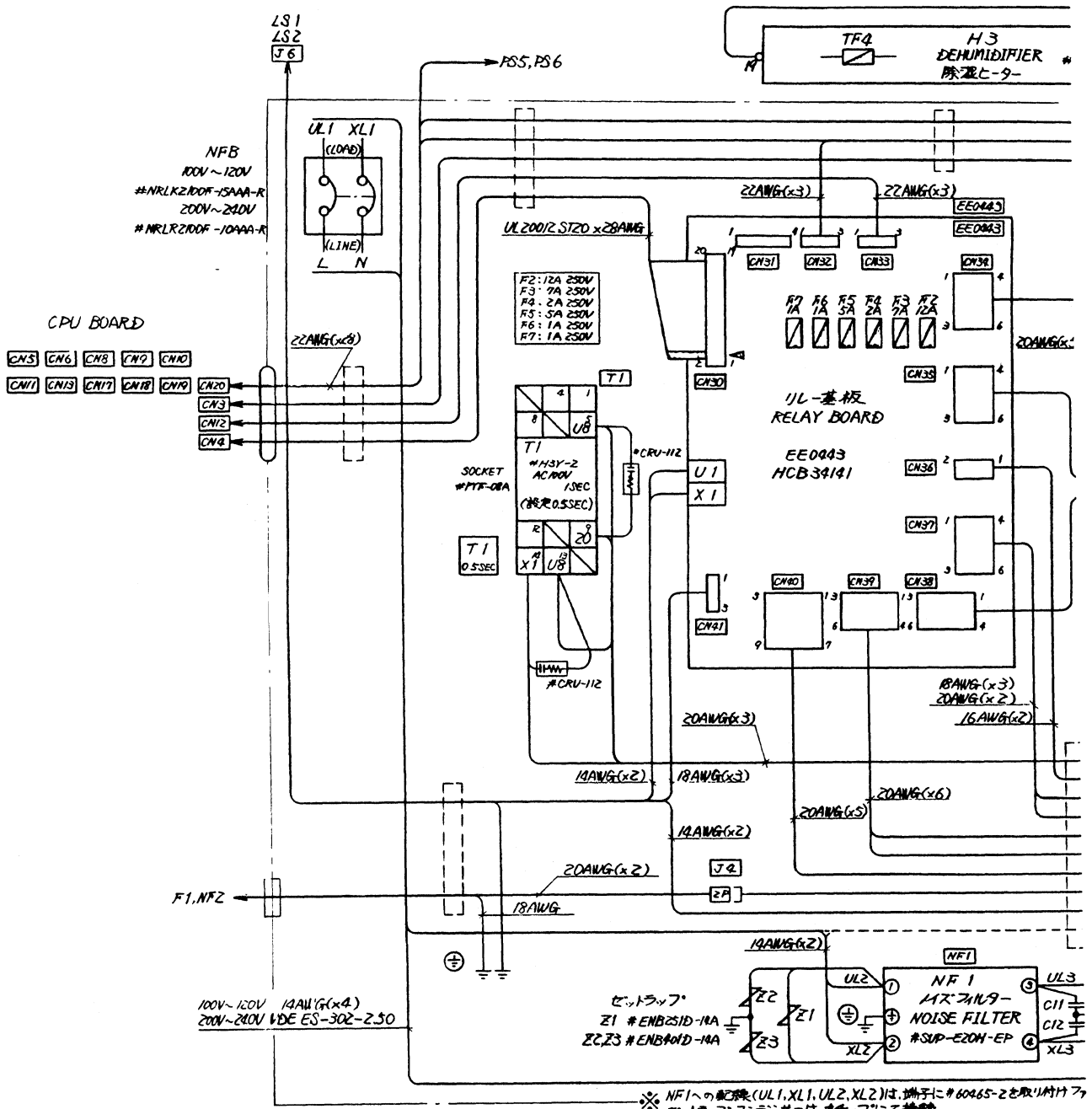

RELAY BOARD UL-基板

CN NO.	PIN NO.	WIRE NO.	行先	CN NO.	PIN NO.	WIRE NO.	行先	CN NO.	PIN NO.	WIRE NO.	行先	CN NO.	PIN NO.	WIRE NO.	行先			
CN 30	1~3	PP9	CPU CN4	CN 31	1	E24	J 1	CN 35	1	U4	L1	CN 38	1	12	C2			
	4~6	E24			2	S1			2	2	TR11		2	11	C1	2	19	
	7	41			3	S2			3	3			3	10		3	19	
	8	42			4	P24			4	4			4	13	C2	4	13	M2
	9	43		1	E24	5	2	CN04	5	14	C3	5	14	H3				
	10	44		2	S3	6	3		6	15		6	15					
	11	45		3	P24	1	3	L	1	10		7	X1	M2				
	12	46		1	E24	2	X1		2	11	M1	8	X1	H3				
	13	47		2	G8	1	5	H1	3	X1		9	X1					
	14	48		3	P24	2	6		4	15		1	17					
	15	49		1	Z6	3	9	FAN1-3	5	14	M3	2	18	H2				
	16	50		2	U8	4	X1	H1	6	X1		3	X1					
	17	51		3	U8	5	X1											
	18	52		4	Z8	6	X1	FAN1-3										
	19	53		5	X1													
	20			6	X1													

LIGHT CONTROL BOARD

CN NO.	PIN NO.	WIRE NO.	行先
CN 42	1	Z3	TR 2
	2	Z4	
	3	Z5	
	4		
	5	Z1	
CN 43	1~10		CPU CN3
	1	Z2	RELAY BOARD CN35
CN 44	2	Z3	



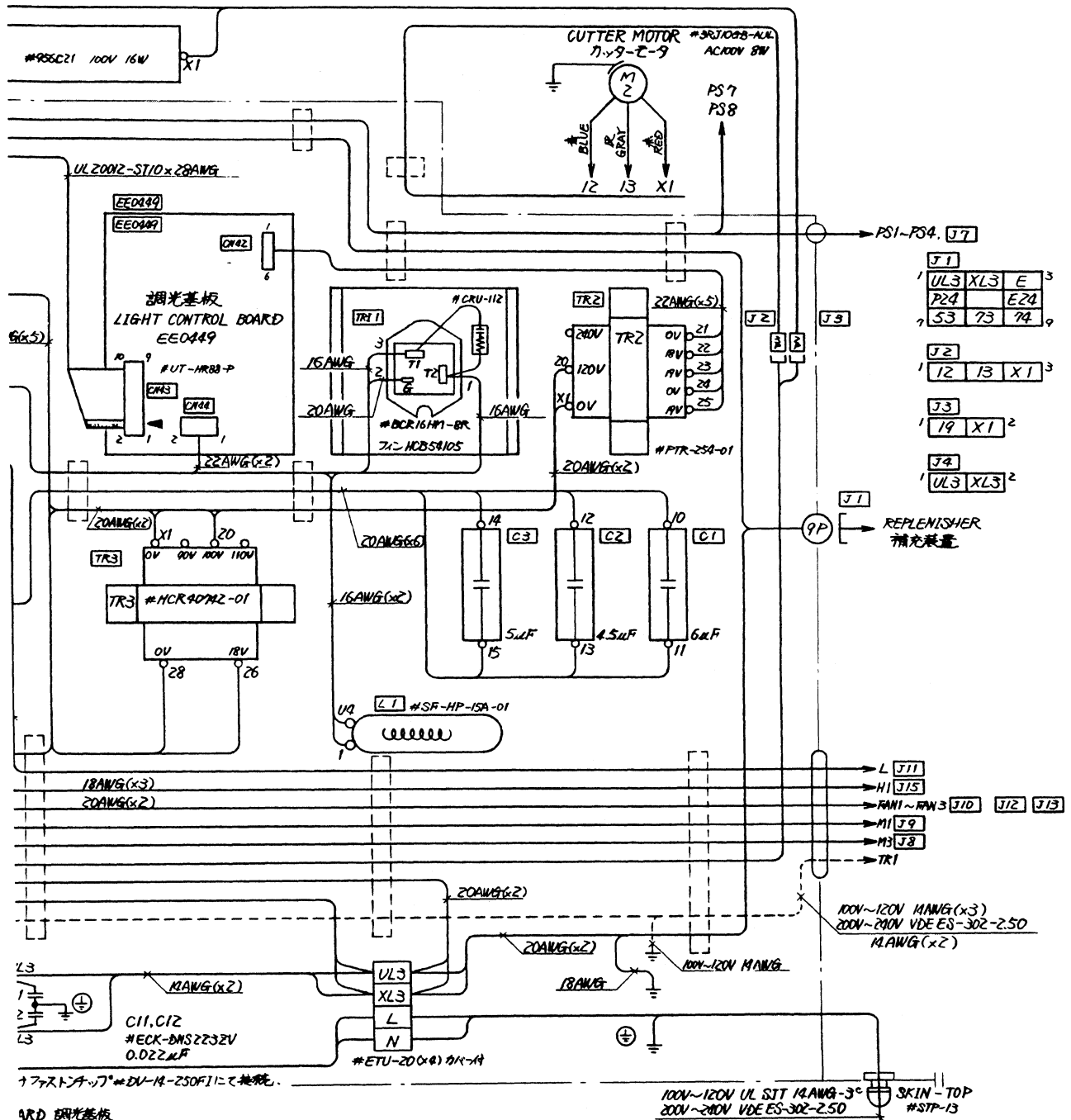

↑ファストナー\*はDN-14-250F1にて接続。

**ARD 調光基板**

- 先行  
※ 14AWG~18AWG —— UL1015 105°C 600V  
20AWG~24AWG —— UL1007 80°C 300V  
HEAT PROOF WIRE —— UL1727 TETRAFLUOROETHYLENE WIRE  
(耐熱線)
- R2  
→ #TA158
- PU  
N3  
LAY  
DARD  
35  
⊕ → アースマーク

NOTES) 1. トランス TR1 が付かない場合は、NFB → NF1 に配線 (UL1-UL2, XL1-XL2) 3-ポット  
2. トランス TR1 付きの場合は、NFB → TR1 → NF1 に配線  
3. トランス制御 (L, N, UL1, XL1) の配線は、ご重疊不意とする。

**DISTRIBUTING BOARD CONNECTION DIA.**

DWG NO. HCM31263

## **MITSUBISHI PAPER MILLS LIMITED**

Head office: Shin-Nisseki Bldg., 7th Floor  
No. 4-2, Marunouchi 3 chome, Chiyoda-ku, Tokyo, Japan  
Tel. Tokyo(03)213-3742

Mitsubishi Paper International, Inc.:  
520 Madison Avenue New York, N Y 10022 U S A. Tel 212-980-9644  
Mitsubishi Paper GmbH  
Kennedydamm 19 4000 Dusseldorf 30 West Germany Tel 0211-4397-215

**IMPORTER**  
**Mitsubishi**  
**International Corp.**  
520 Madison Avenue New York  
N Y 10022 U S A  
General Merchandise Div  
Tel 212-605-2355

**IMPORTER**  
**Mitsubishi**  
**Canada Ltd.**  
Toronto Office  
Suite 2181  
Commerce Court West,  
Toronto 111 Ontario Canada  
General Merchandise Dept -B  
Tel 416-362-6731