

mitsubishi GRAPHIC ARTS SYSTEM

CP-324S

WARNING

This equipment generates uses and can radiate radio frequency energy and if not installed and used in accordance with the instruction manual, may cause interference to radio communications. It has been tested and found to comply with the limits for a Class A computing device pursuant to Subpart J of Part 15 of FCC rules, which are designed to provide reasonable protection against such interference when operated in a commercial environment. Operation of this equipment in a residential area is likely to cause interference in which case the user at this own expense will be required to take what ever measures may be required to correct the interference.

CONTENTS

1. INTRODUCTION	3
2. SPECIFICATIONS	4
3. GENERAL DRAWINGS	5
4. PROCESS CHART	6
5. PRECAUTIONS IN HANDLING	7
6. CONDITIONS FOR INSTALLATION	8
7. MACHINE DESCRIPTION	9
7 - 1 General Structure	9
7 - 2 Description of the Componets	10
7 - 2 - 1 Main switch	10
7 - 2 - 2 Control panel	11
7 - 3 Copy Holder (Original Carriage)	17
7 - 3 - 1 Loading the copy	17
7 - 3 - 2 Positioning the copy	17
7 - 4 Lens-Mirror Section	18
7 - 5 Photographing Section	19
7 - 5 - 1 Loading a Silver Master roll	19
7 - 5 - 2 Exhaustion of the material	20
7 - 5 - 3 Splice detection	20
7 - 6 Processor	21
7 - 6 - 1 Preparation of processing solutions	21
7 - 6 - 2 Developing tank	21
7 - 6 - 3 Stabilizing tank	22
7 - 6 - 4 Replenishment	22
7 - 6 - 5 Changing the processing solutions	22
7 - 6 - 6 Control of Activator Level I	22
8. PHOTOGRAPHING	23
8 - 1 Photographing Procedure	23
8 - 2 How to Determine Standard Exposure	24
8 - 3 How to Determine the Optimum Exposure for the Copy	25
9. MAINTENANCE	26
9 - 1 Maintenance Mode	26
9 - 2 Routine Maintenance	27
9 - 2 - 1 Processor	27
9 - 2 - 2 Replacement of the cutter blade	28
9 - 2 - 3 Replacement of the halogen lamp	28
9 - 2 - 4 Care of the copy glass plate	29
9 - 2 - 5 Lans-mirror section	30
9 - 2 - 6 Dryer	30
9 - 3 Lubrication	31
9 - 4 Ordering Parts	32

10. TROUBLE SHOOTING	33
10 - 1 Error Messages	33
10 - 2 Cutter Malfunction	33
11. OPTIONAL ACCESSORIES	34
11 - 1 Component Location	34
11 - 2 Control Panel	35
11 - 3 Operating the Replenishment Device, and Changing Replenishment Time	35
11 - 3 - 1 Automatic replenishment mode	35
11 - 3 - 2 Initial replenishment mode	37
11 - 4 Control of Activator Level II	38
12. WIRING DIAGRAMS	39

1. INTRODUCTION

We at mitsubishi thank you for selecting the Silver Master Platemaker CP-324S.

The CP-324S deals with a wide size range of plates from A4 to A3 (lengthwise) , using the Silver Master R II (SLM-R II) or Silver Master F (SLM-F) as master material.

The CP-324S, by a simple operation, produces offset master plates directly from the original copy, eliminating the need for any intermediate film process.

This operation manual provides information to ensure continued satisfactory operation of the machine. Please read it prior to usage.

For information-on printing methods, please refer to our booklet, "Silver Master Technical Guide."

2. SPECIFICATIONS

Loading capacity :	1 roll (SLM-R II or SLM-F)
Master width :	229 mm (9") , 254 mm (10") , 279 mm (11") . 305 mm (12") , 310 mm (12 - 1/5") , 324 mm (12 - 3/4")
Master feed length :	225 ~ 480 mm (in 1mm increments)
Effective exposure area :	310 × 450 mm
Max. exposure area :	324 × 480 mm
Max. copy size :	310 × 450 mm
Max. copy carrier size :	395 × 530 mm
Lens :	f = 210 mm F : 11 (fixed diaphragm)
Magnification :	100% (fixed)
Exposure method :	Slit exposure with copy and material movements
Copy mounting method :	Copy image face down ; 180 mm pin bar provided
Multiple exposure :	Automatic double exposure, multiple exposure
Cutter :	Sliding knife
Exposure control :	Digital illuminance control 0 ~ 99
Light source :	One halogen lamp 80V , 650W
Control panel :	Flat panel for interactive operation
Master splice detection :	Display, alarm buzzer, automatic cut beyond preset length
Dehumidifier :	Heater
Processor tank capacity :	Activator 6 ℓ , Stabilizer 4.4 ℓ
Replenisher container capacity :	Activator 1 ℓ , Stabilizer 1 ℓ
Initial platemaking rate :	1' 58" (master length 450 mm) / 60Hz
Cyclic platemaking rate :	52" (master length 450 mm) / 60Hz
Copy moving speed :	19.0 mm / sec / 60Hz
Processor speed :	12.0 mm / sec / 60Hz
Activator temperature control :	300W panel heater with thermostat (29 ± 3 °C) ; heater off during exposure
Dryer :	350W fin heater, high / low switching with thermo-control
Safety measures :	in compliance with the relevant safety standards
Electricity :	100 VAC, 1.15 kw
Machine dimensions (W×D×H) :	1000 × 595 × 790 mm — main body only 1000 × 595 × 1030 mm — support legs attached
Weight :	115 kg (no chemicals included)
Option :	Replenishment device

3. GENERAL DRAWINGS

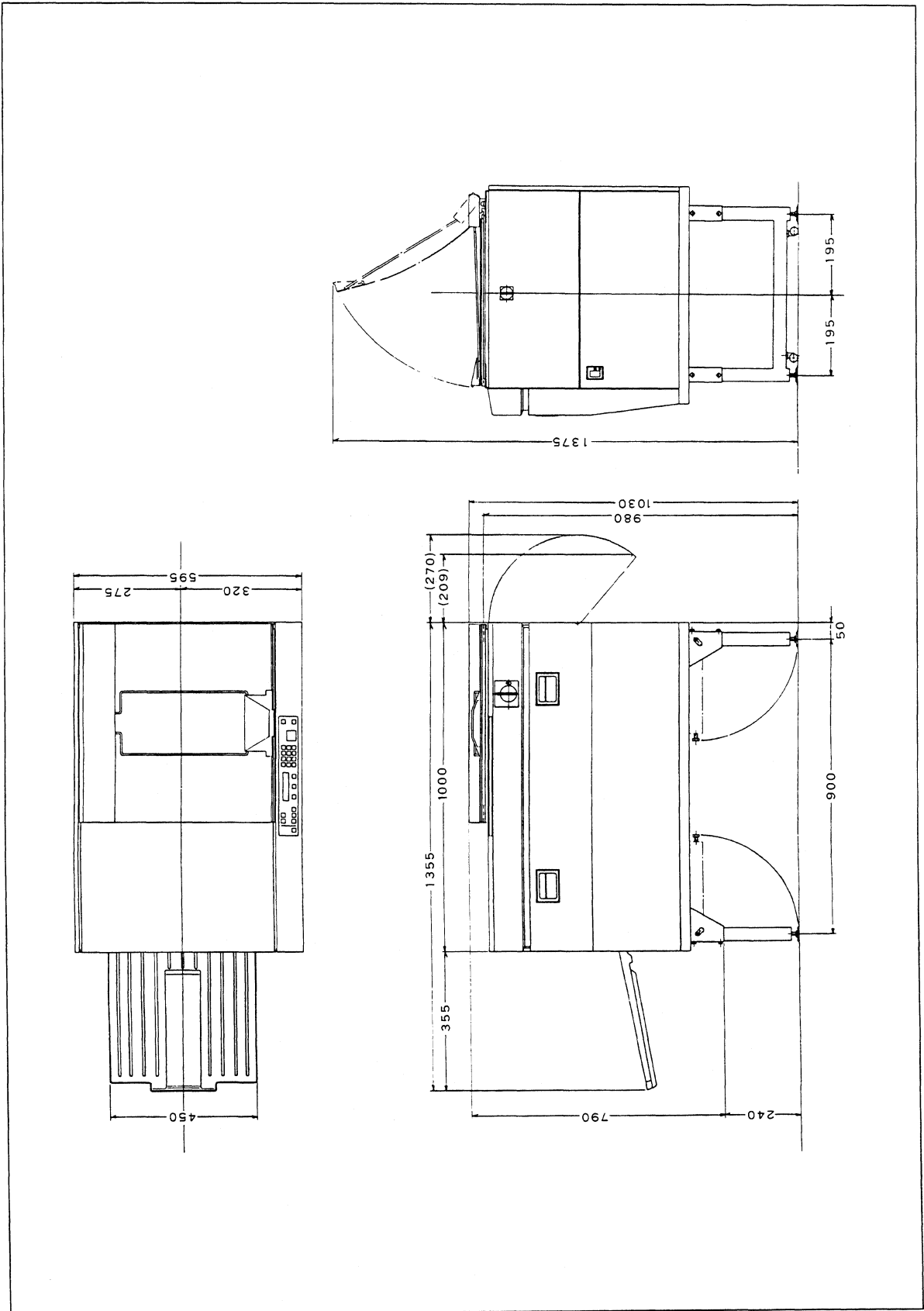

4. PROCESS CHART

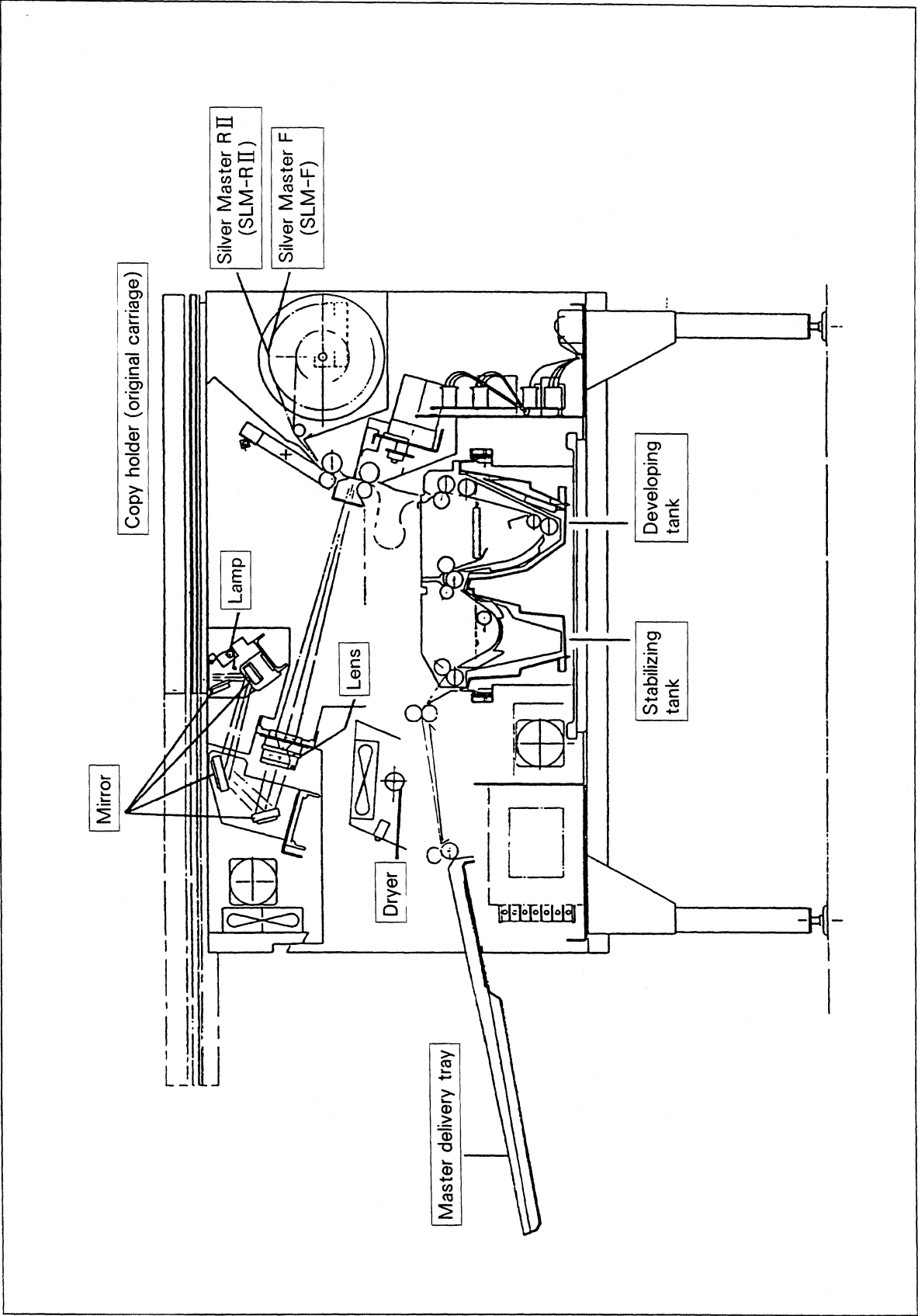

5. PRECAUTIONS IN HANDLING

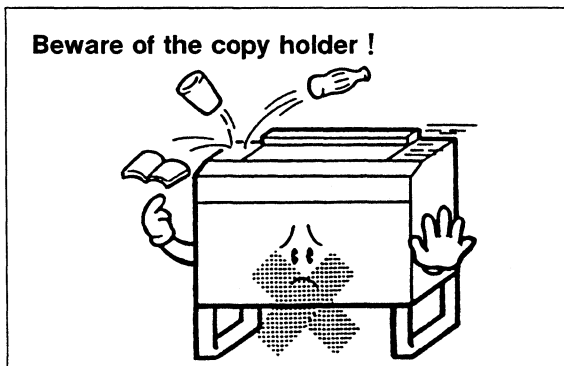

Don't put anything on the copy holder. Upon pressing the start button, the holder moves to the left.

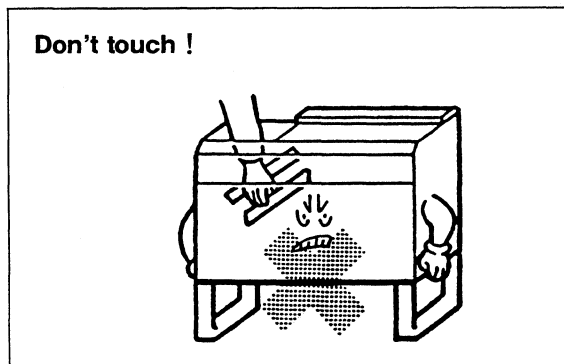

When cleaning the lens/mirror, don't touch them as this may cause deterioration in performance and quality.

6. CONDITIONS FOR INSTALLATION

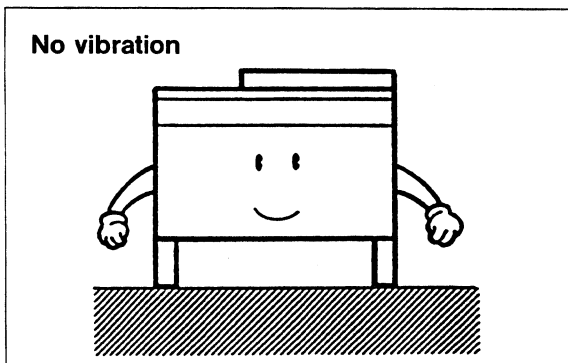

Choose a vibration-free place with an even, level floor surface. The machine with no chemicals weight 115 kg.

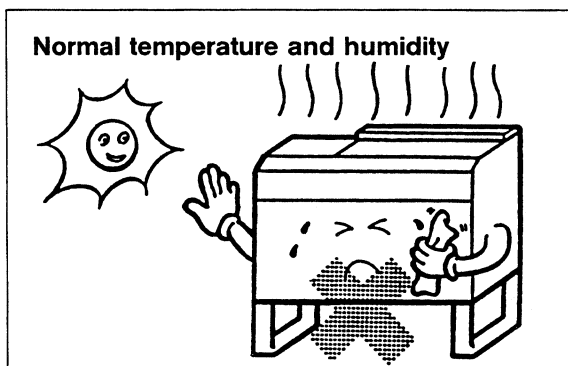

The room temperature should be between 10 to 30°C and the humidity between 40 to 70% . Avoid direct sunlight.

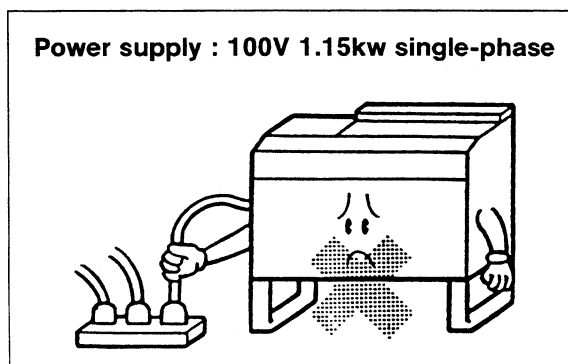

Use an outlet with an ampacity of 15A or more, and keep voltage fluctuations within +10 to -10% . Never fail to earth the machine in accordance with the relevant safety standards. Don't put too many loads on one outlet.

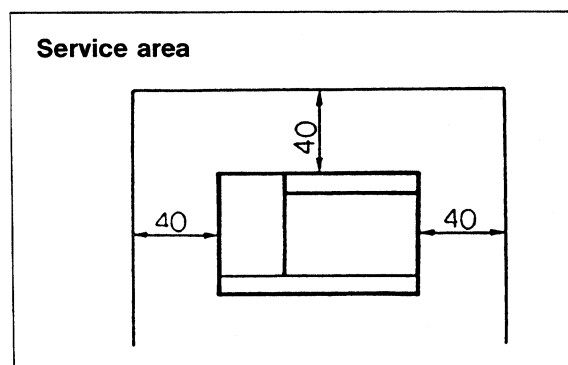

Be sure to keep a clear space around the machine for maintenance. Machine dimensions (W×D×H) : 100 × 59.5 × 103 cm

7. MACHINE DESCRIPTION

7 - 1 General Structure

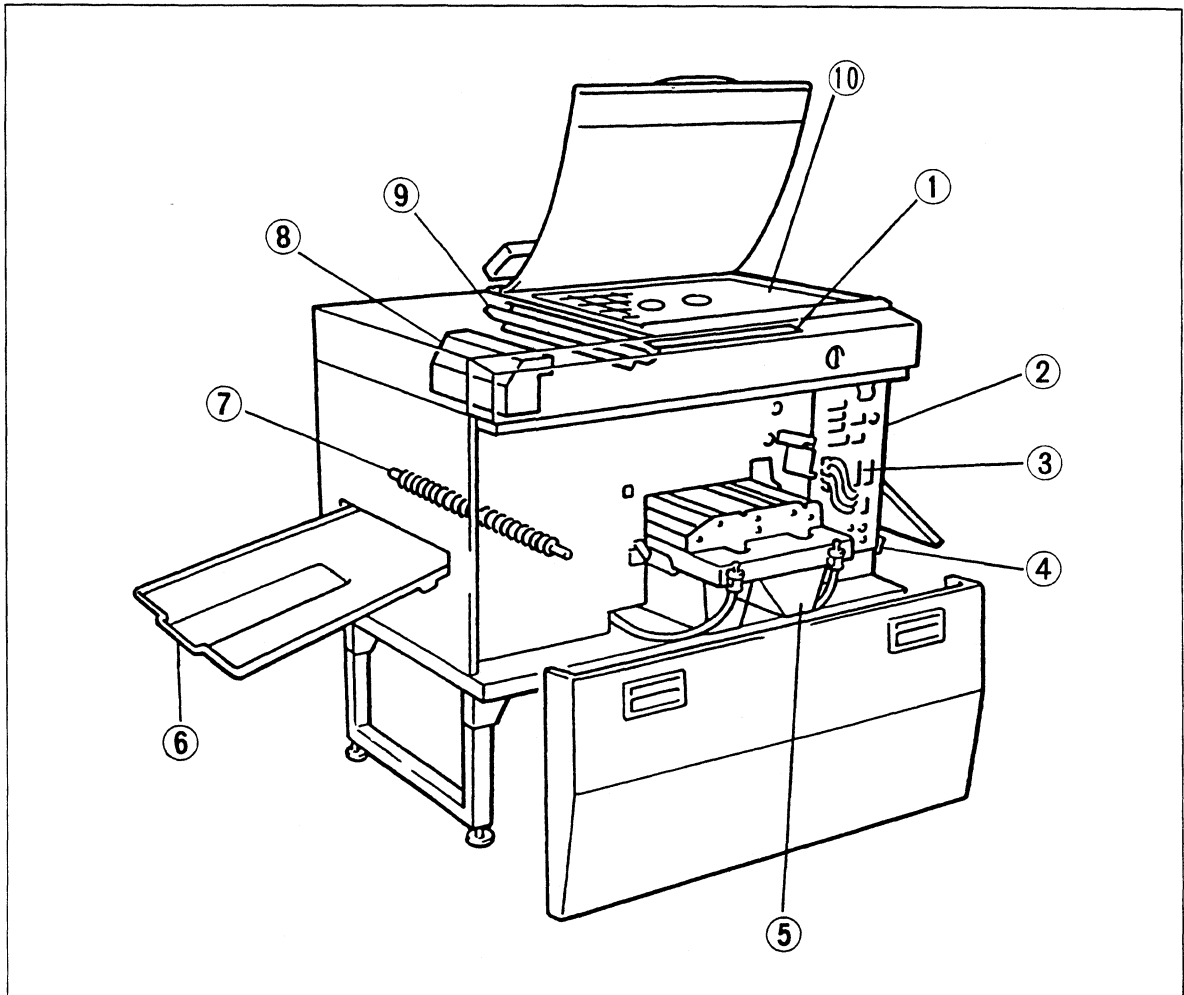

- ① Control panel
- ② Master magazine
An SLM roll is loaded here.
- ③ Control board CPU
- ④ Main switch
- ⑤ Processor
Develops and stabilizes exposed materials.
- ⑥ Master delivery tray
- ⑦ Dryer
Dries developed and stabilized materials.
- ⑧ Lens / mirror section
- ⑨ Lamp unit
Contains a halogen lamp for reflection.
- ⑩ Copy holder (original carriage)
Holds the copy in position.

7 - 2 Description of the Components

7 - 2 - 1 Main switch

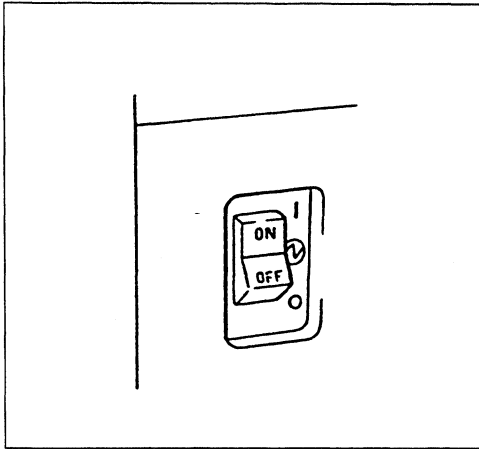

When this switch is turned on, the control circuit, processor motor, dryer, panel heater, etc. also come on and various items to be checked appear in sequence on the display. The operator must then carry out the necessary checks for start-up. Each item is displayed for five seconds.

NOTE : Nothing appears on the display one second after the power is turned on.

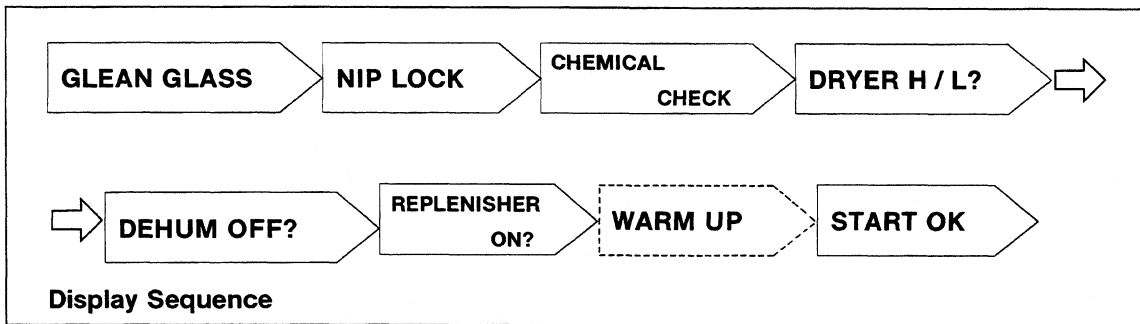

To stop the display, press 

For restart, press 

7 - 2 - 2 Control Panel

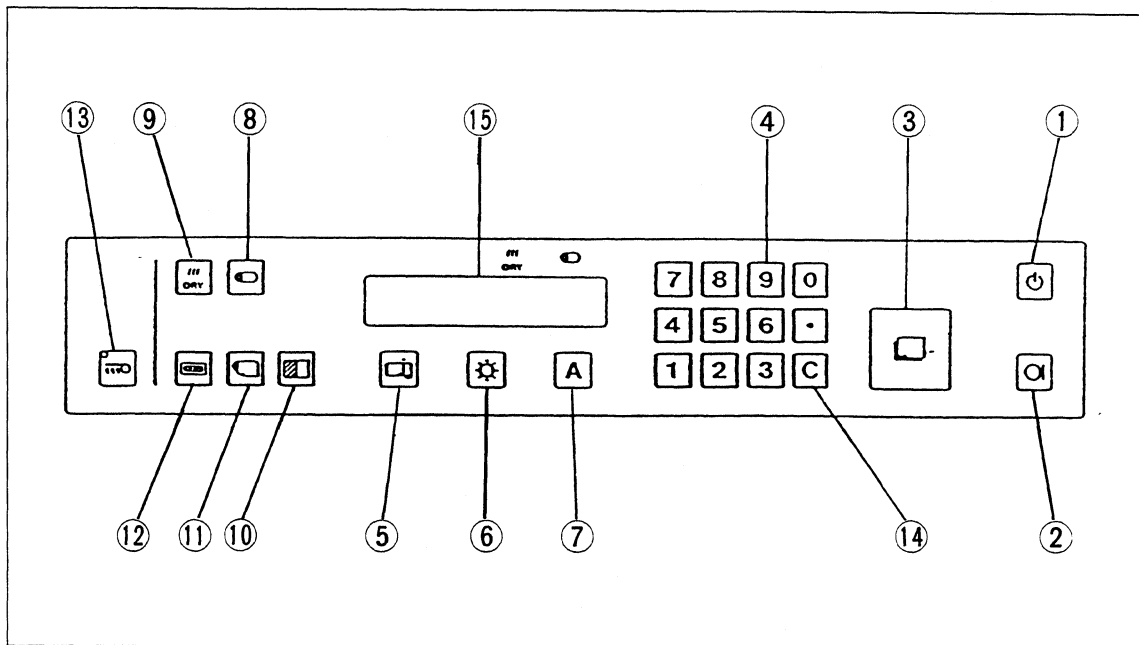

① Standby key





This key is used to save electricity when operation of the machine is stopped temporarily for some reason. To cancel the standby state, press the switch again. "STAND BY" appears on the display while the machine is on standby.

② Power key

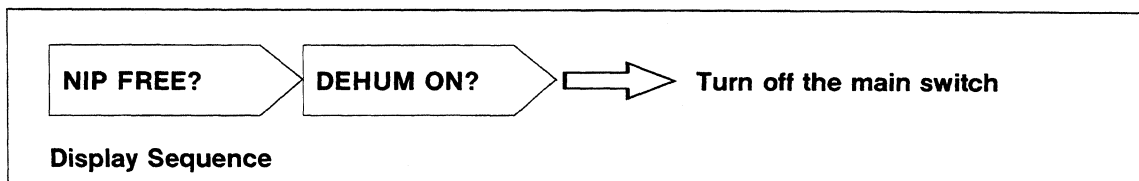

When this key is pressed to terminate operation, items to be checked at shut-down appear in sequence on the display and the operator then carries out the necessary checks for shut-down. Display of one item lasts five seconds.



CAUTION : To turn off the machine while still leaving the de-humidifier in action, don't turn off the main switch : use this power key  only.

③ Start key



When this key is pressed while "START OK" is on display, the machine starts the platemaking operation. The key also functions as follows :

- 1) When pressed during the start-up or shut-down checkup display, the display at that moment is held. To clear the display, press  key.
- 2) The multiple-exposure (division) mode can be started only after the preceding plate has been completely delivered from



the machine. If this key is pressed before complete delivery of the preceding plate, the following messages will appear :
“TRANSPORT”
“WAITING”

④ **Numeric key pad**

These keys are used to enter various numerical data.

⑤ **Master length input key**



Enter the desired master length data (in mm) using the numeric key pad, and then press . The master length data entered appears on the display.

NOTE : If data outside the permissible setting range (225 – 480) is entered, the message “SET UP ERR” appears on the display. Press  to reenter.

⑥ **Exposure control key**



Enter the desired exposure level (0 – 99) for exposure control, using the numeric key pad, and then press . The exposure level entered appears on the display.

(The recommended exposure level is 50 to 70, though it depends on the copy image density level.)



Setting larger numbers increases the exposure level (illuminance) while setting smaller numbers decreases it.

⑦ **AUTO memory key**





The master length and exposure level most frequently used can be stored so that the data can be recalled simply by pressing .

• Exposure level entry

Enter the desired exposure level using the numeric key pad, and press  while holding  (exposure control key) down.

• Roll length entry

Enter the desired roll length using the numeric key pad, and press  while holding  (master length input key) down.

⑧ **Roll width input key**



Enter the desired roll width (in mm) using the numeric key pad, and then press . The roll width data entered appears on the display.

NOTE : If the optional automatic replenishment device is used, be sure to enter the roll width data. The device calculates the cumulative area of processed material from the input master length and roll width, and automatically makes a replenishment every time 1 square meter of material has been processed.

⑨ **Dryer key**



This key is used to choose high or low temperature for the dryer heater. The choice should be made depending on the degree of wetness of the master.

HIGH : Choose H when the atmospheric temperature is low and the plates which have passed the dryer seem insufficiently dry or when the Silver Master F (SLM-F) is used.

LOW : Choose L when the Silver Master R II is used.

⑩ Multiple exposure key (Division mode key)



This key is used for multiple exposure (automatic double exposure and manual multiple exposure).

1) Automatic double exposure (2 DIV)

///
DRY

START OK	L	310
400 mm	70	

NORMAL MODE



ORIG. LENG?	2 DIV	
400 mm	70	

2 DIVISION MODE



GRIP?	2 DIV		
400 mm	70	30	



ORIG. LENG?	2 DIV		
400 mm	70	150	



START OK	2 DIV	030
400 mm	70	

Press once. (If pressed three times, the division mode will be cleared.)

Press + , and the "GRIP?" message will appear. Enter the gripper margin date.

e. g.) If a gripper margin of 30 mm is desired, enter 30 using the numeric key pad and press .

Enter the data for "ORIG. LENG?"

e. g.) If the copy length is 150 mm, enter 150 using the numeric key pad, and press .

Position the left edge of the copy 30 mm from the reference (zero) line at the left side of the copy positioning sheet.

As is pressed, two exposures are successively made, and the plate thus exposed is processed and delivered automatically.

NOTE : The input data for "ORIG. LENG?" should be less than one half of the input master length minus the gripper margin.

If a longer length than that is set, the "SET UP ERR" message will appear. Press to clear the message, and reenter.

2) Multiple exposure (DIV)

START OK	L	310
400 mm	70	

NORMAL MODE



START OK	DIV	150
400 mm	70	

DIVISION MODE



START OK	DIV	020
400 mm	70	



START OK	DIV	100
380 mm	70	

280 mm

180 mm

80 mm

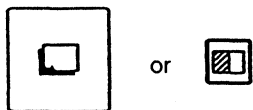

⑪ Roll consumption check key



///
DRY



START OK	L	310
0075 cm	70	

- Press twice. (If pressed three times, the division mode is cleared.)
- Enter the gripper margin.
e. g.) If a gripper margin of 20 mm is desired, enter 20 using the numeric key pad, and press .
- Press , and the material will be transported by the gripper margin entered (20 mm) .
- Enter the copy length.
e. g.) If the copy length is 100 mm , enter 100 using the numeric key pad, and press .
- position the left edge of the copy to the reference (zero) line of the copy positioning sheet, and press .
- Each time is pressed, the remaining amount of input master length (amount available for exposure) is displayed.
- This operation may be repeated as long as the input master length is not going to be exceeded.
- When the remaining master length for the last exposure is the same as the copy length, press ; if not, press .

The total amount of the material consumed so far is displayed while this key is held down.
e.g.) "0075 cm" : 75 cm of material has been consumed.

To reset the roll consumption display :

- 1) press + . The display turns to "0000".
- 2) If the roll is exhausted, the roll consumption display is automatically reset.

⑫ Counter key

START OK	L	310
2395	70	

• While this key is held down, the number of plates so far made appears on the display.
e. g.) “2395” : means that 2395 plates have been made so far.

To reset the counter :

1) press  + .

The display turns to “0000”.

⑬ Dehumidifier switch



This switch is used to turn the dehumidifier (defogger) on or off. Depending on atmospheric conditions, the device is used for dehumidification inside the machine and prevention of dew condensation due to sudden temperature changes.

To keep the device working while the machine is out of operation, turn off  (power key) ; don't turn off the main switch.

⑭ Clear key



This key is used not only for cancellation, but also for the following :

- 1) To clear entry errors (“SET UP ERR”)
- 2) To stop the sounding of the buzzer when the roll is exhausted or replaced.
- 3) To stop operation after the machine has been started in order to alter data or for other reasons.

When the key is pressed, the halogen lamp goes out after a minimum 225 mm length of material has been fed. The material is then cut, and the copy holder returns to the original position.

- 4) To pass the sequence of items appearing on the start-up or shut-down checkup display.

CAUTION : When the “WARM UP” message is cleared, this means that the processing solution has not reached an adequate processing temperature. The power key should be switched off and switched back on again.

⑮ Display 

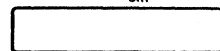

1. The display shows what is going on in the machine during operation and error messages.

[CONDITION CHECK]

- A. ENPTY (buzzer sounding)
There is no material, or the Silver Master roll is exhausted.
- B. COPY POSIT
The copy holder is not at its original position.
(See 9. MAINTENANCE.)
- C. CUTTER ERR
The cutter assembly is not at its original position.
(See 9. MAINTENANCE.)
- D. SET UP ERR
The input data is outside the permissible setting range.

- E. WARM UP
The temperature of the precessing solution is below the preset level.
 - F. ROLL JOINT
WAITING (intermittent buzzer sounding)
A splice in the material has been detected.
 - G. TRANSPORT / WAITING
The material is coming out of the machine.
 - H. CHK REPL
Check to see if the automatic replenishment device (option) is turned on.
 - I. START OK
The machine is ready for operation.
 - J. DOOR!
Close the front cover.
 - K. ORIG. LENG?
Enter the copy length when the division mode for multiple exposure is used.
 - L. REPLENISH SOLUTION (buzzer sounding)
Add replenisher to processor solutions.
 - M. REPL IN WAITING
Replenishment is in progress (option) .
 - N. CHECK PROCESSOR (buzzer sounding)
Check processor for replenishment trouble.
2. Roll width display
 3. Exposure level display
 4. Master length display
 5. Dryer high / low (H / L) display
 6. Other data display

7 - 3 Copy Holder (original carriage)

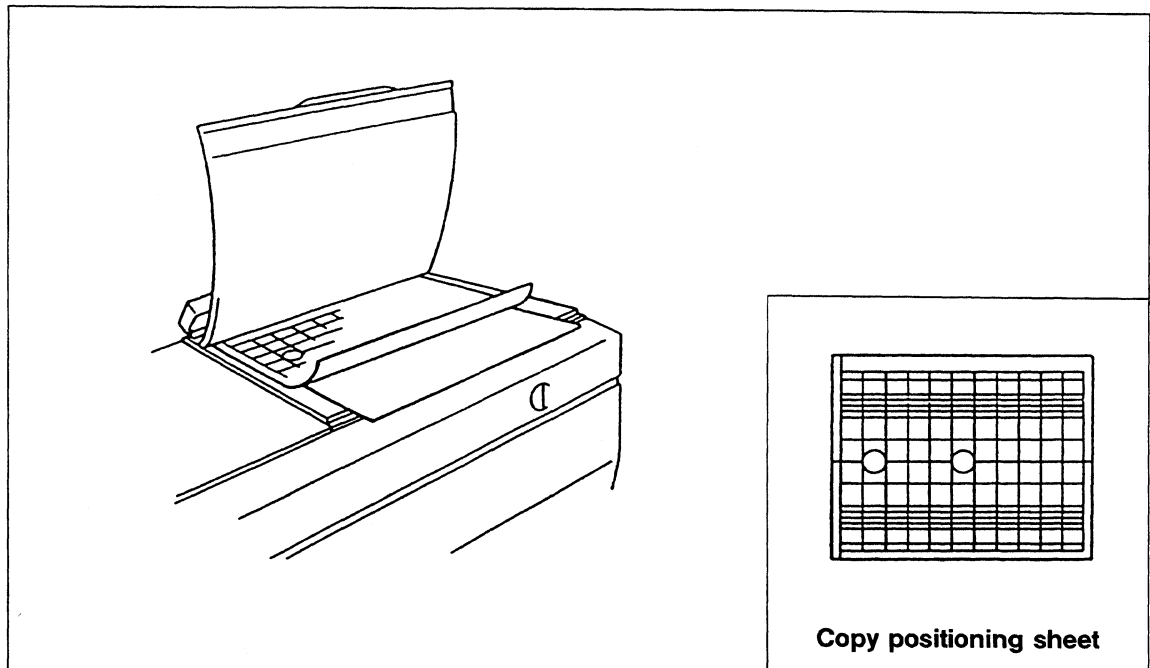

CAUTION : The copy holder moves from right to left. Don't put anything on the top of the machine.

Don't touch the copy holder while it is motion.

7 - 3 - 1 Loading the copy

- ① Lift the copy cover gently by its handle.

The cover has springs which make it stop at a fixed position. (Hold the handle until the cover is stationary.)

- ② Place the copy between the copy positioning sheet and the copy glass plate.

Close the copy cover gently.

CAUTION : Open and close the copy cover gently ; if it is handled abruptly, machine trouble can occur.

7 - 3 - 2 Positioning the copy

- ① The reference line "0" in the copy positioning sheet corresponds to the leading edge of the material.

Since the slit exposure system creates a doubly exposed area of about 5 mm at each end of a plate, this area cannot be photographed.

- ② The sheet is ruled into 5 mm squares, which permits easy and accurate positioning of the copy.

7 - 4 Lens-Mirror Section

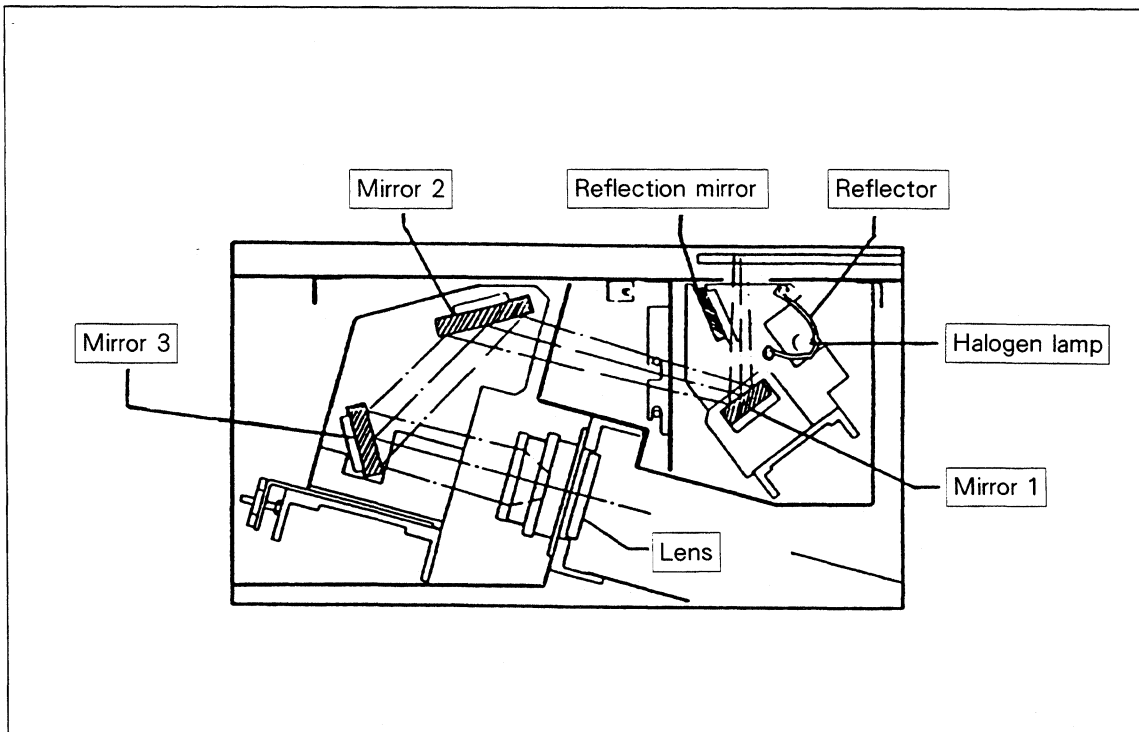

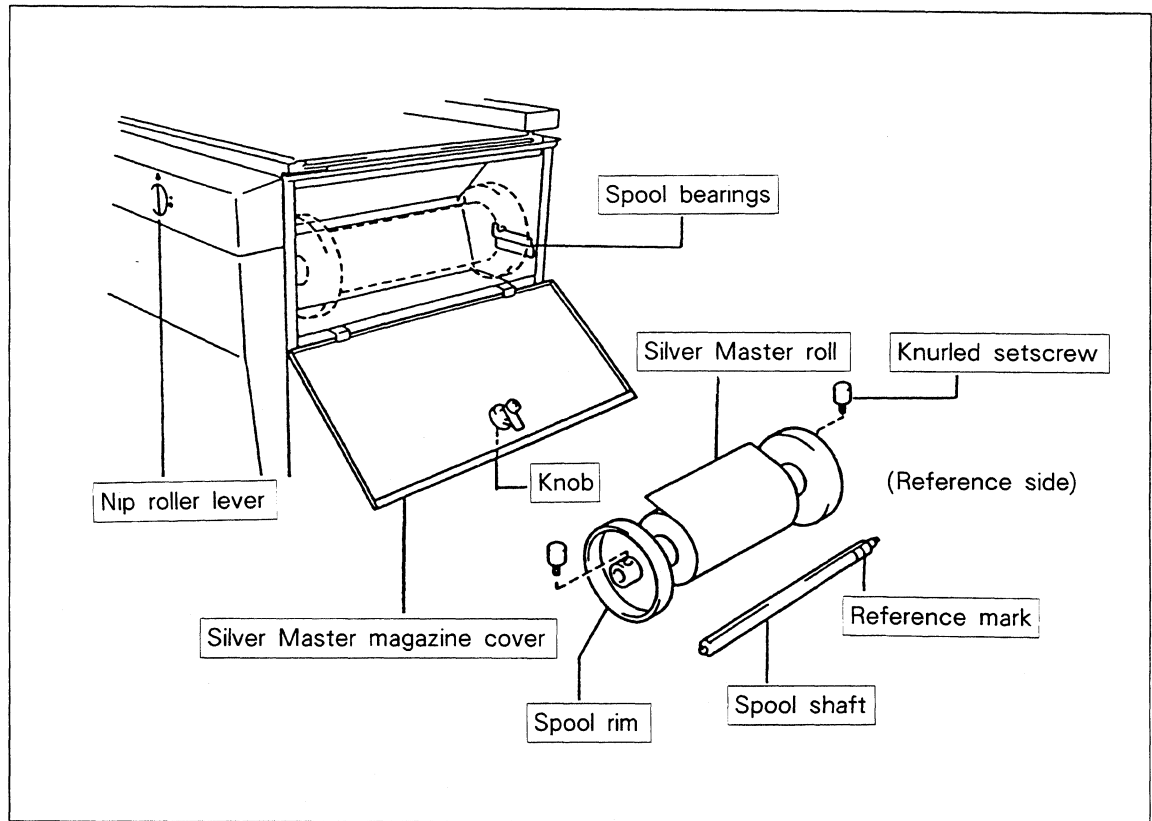

- The light which comes directly from the lamp, and the light reflected by the reflector and reflection mirror are cast on the copy.
- The light from the copy (image) is reflected by mirror 1; the reflected light strikes upon mirror 2 and then upon mirror 3, and finally passes through the lens to reach the material.
- While the lens and mirrors are fixed, the copy holder moves to the left, causing the copy image to be projected on the material. The material moves synchronously with the movement of the copy holder so that the image is reproduced on the material.
- The lens has a focal length of 210 mm . The lens is used with the stop value set at F 11.
- The machine should be placed where there is minimum of dust and humidity so that the mirrors are not affected.
- When replacting the lamp or cleaning the inside of the machine, don't touch the mirrors or the lens.

7 - 5 Photographing Section



7 - 5 - 1 Loading a Silver Master roll

1) Silver Master R II (SLM-R II)

- ① Turn the knob of the Silver Master magazine cover and pull it to open the cover.
- ② Align the reference spool rim with the appropriate reference mark on the spool shaft corresponding to the width of the roll use (229 mm ,254 mm ,279 mm ,305 mm ,310 mm ,324 mm) and fix it with the knurled setscrew (screw up against the flat surface) .
- ③ Pass the spool shaft through the roll core hole and fit core to the reference spool rim. The winding of the roll should be clockwise as viewed from the reference spool rim side.
- ④ Attach the other spool rim to the spool shaft and fix it with the knurled setscrew.
- ⑤ Place the spool shaft on the spool bearings.
- ⑥ Completely remove the adhesive tape fixing the leading edge of the roll.
CAUTION : Take care not to leave any tape adhesive on the roll.
- ⑦ Turn the nip roller lever to  (the free position) .
- ⑧ Pass the material between the nip roller and roller until the buzzer stops sounding. From here, move it manually by approx. 50 mm further forward.
- ⑨ Turn the nip roller lever to  (the lock position) .
- ⑩ Close the magazine cover.

2) Silver Master F (SLM-F)

- ① Since each SLM-F roll has its factory-attached spool, it can simply be loaded in the magazine.

CAUTION : Never remove or loosen the spool.

If the spool should be removed, the SLM-F roll would become foggy at the sides due to external light (room light) .

- ② The rest of the procedure for loading an SLM-F roll is exactly the same as that for loading a Silver Master RII (SLM-R II) roll.
- ③ About 2m of leader paper is attached to avoid fogging; remove it just before use.

7 - 5 - 2 Exhaustion of the material

If the material runs out while being fed, "EMPTY" appears on the display and the buzzer sounds.

The remaining material is carried on to the processor so that no strips of material remain in the photographing section.

Strips of material in the processor may be removed either by hand, or automatically by pressing  after loading a new roll.

7 - 5 - 3 Splice detection

Some Silver Master rolls have a splice. If a splice is detected, "ROLL JOINT WAITING" appears on the display and the buzzer sounds intermittently.

There are two cases of splice detection:

- ① When the length between the material's leading end and its splice, (α), is shorter than 265 mm :
The material will be shifted on by $\alpha + 285$ mm .
- ② When the length between the material's leading end and its splice, (α), is 265 mm or longer:
 - The material will be moved to a distance of length α .
 - Then it will automatically be shifted 285 mm.

7 - 6 Processor

When the main switch is turned on, the drive motor is started and the conveyor unit rollers start turning.

At the same moment, the panel heater is activated.

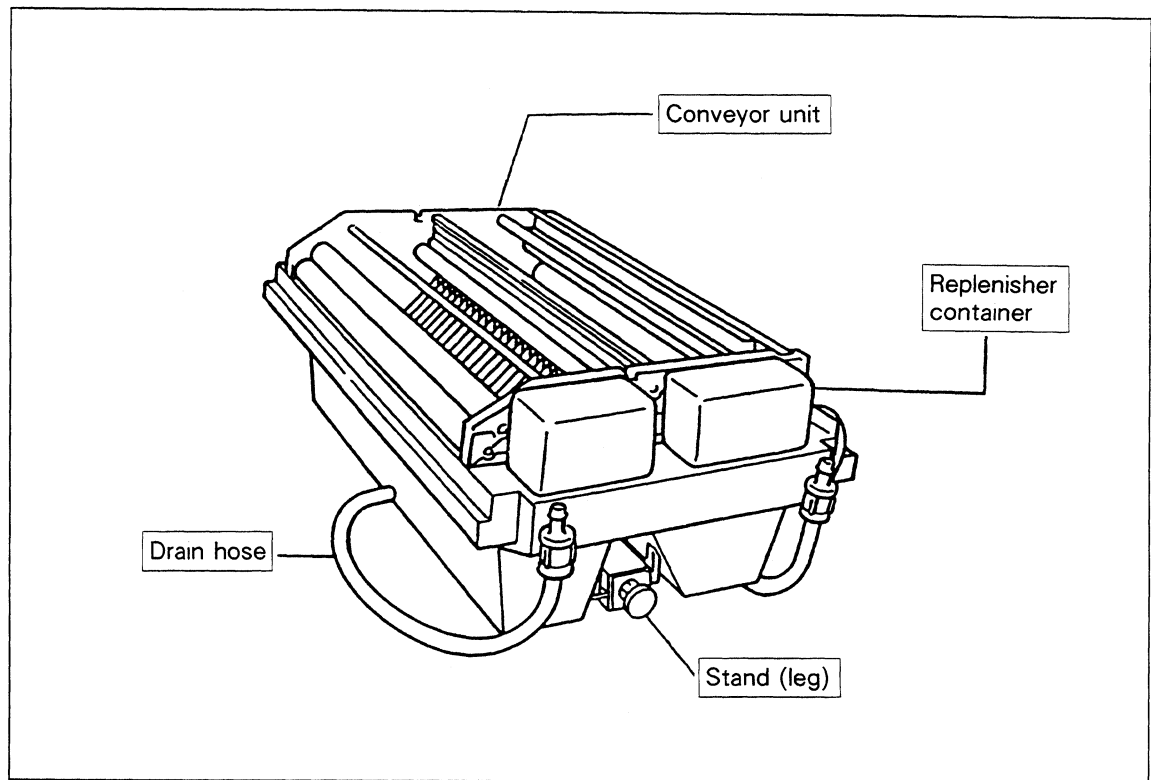

7 - 6 - 1 Preparation of processing solutions

- Take off the processor cover and unhook the processor, so that the processor can be pulled out of the main body.
- The processor consists of a tank unit incorporating a developing tank and a stabilizing tank, and an integrated conveyor unit mounted on the tank unit. The developing tank is provided with a 300W panel heater with a built-in thermostat so that the activator temperature is maintained around 30°C. After the machine has been out of operation for a long period of time, the conveyor rollers might stick to each other and so might not turn smoothly. In such a case, turn the rollers by hand before starting the processor.
- When preparing the processing solutions, use only the measuring cup supplied.
- Use warm water, 30°C to 35°C (86° to 95°F) when tap water temperature is low in winter. Be careful not to mix the activator and stabilizer when pouring them since they have a reaction to each other.

7 - 6 - 2 Developing tank (capacity: 6 liters)

Preparation of activator—mixture ratio of SLM-AC to water 1:1

- ① Add 3 liters of water to 3 liters of SLM-AC (undiluted), exclusive activator for SILVER MASTER, and stir thoroughly. Then pour the mixture into the developing tank.
- ② Pour the activator prepared in the same ratio (1:1) into the activator replenisher container (1 liter), and mount the container properly on the unit.

7 - 6 - 3 Stabilizing tank (capacity 4.4 liters)

Preparation of stabilizer —mixture ratio of SLM-ST to water 1:3

- ① Add 3.3 liters of water to 1.1 liters of SLM-ST (undiluted) , exclusive stabilizer for SILVER MASTER, and after stirring thoroughly, pour it into the stabilizing tank.
- ② Pour the stabilizer prepared in the same ratio (1:3) into the stabilizer replenisher container (1 liter), and mount the container properly on the unit.

7 - 6 - 4 Replenishment

Each of the replenisher containers should always contain a sufficient amount of processing solution properly mixed. As the replenisher (processing solution) runs out, the liquid level in the tank becomes low, which accelerates solution fatigue and causes deterioration in the plate quality.

7 - 6 - 5 Changing the processing solutions

Refer to 9-2 Routine Maintenance.

7 - 6 - 6 Control of Activator Level I

When the level of activator in the processor is below a certain level, a warning will appear on the display and the buzzer will sound.

(The machine will not start.)

REPLENISH
SOLUTION

Replenishment Procedure

1. Press **[C]** to turn off the buzzer.
2. Take off the processor cover and pour processing solution into the tank and the replenisher container.

Cautions in Handling Processing Chemicals

- ① Never drink the processing chemicals, nor allow them to get in your eyes, (Should anything like this happen, see a doctor.)
- ② If the processing chemicals get on your skin or clothes, immediately wash thoroughly in running water.
- ③ Use the processing chemicals correctly as prescribed in the instructions for use.
- ④ Keep them out of reach children.

8 . PHOTOGRAPHING

8 - 1 Photographing Procedure

- ① Turning on the main switch
(start-up check)



Turn on the power switch to activate the machine and make it ready for operation.

- ② Roll width selection

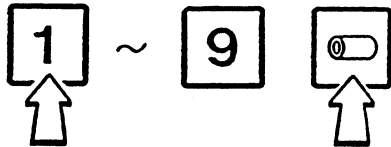

Enter the roll width to be used using the numeric key pad and press the roll width input key .

- ③ Dryer HIGH/LOW selection



Select H (igh) or L (ow) with the dryer key  depending on the wetness of the plate delivered.

- ④ Master length selection

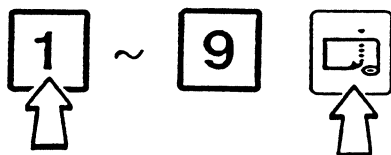

Enter the master length using the numeric key pad and press the master length input key .

- ⑤ Exposure level input

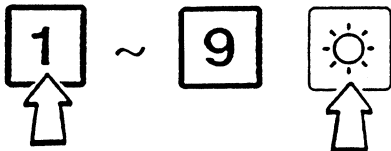

Enter the exposure level suitable for the copy, using the numeric key pad, and press the exposure control key .

- ⑥ Exposure mode selection
(normal/double/multiple)



When double or multiple exposure is desired, use multiple exposure key .

- ⑦ Mounting the copy



Put the copy on the copy grass plate with its image face down and place it in the desired position using the ruling of the copy positioning sheet.

- ⑧ Pressing the start key 

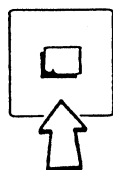

When "START OK" appears on the display, press and exposure starts automatically.

8 - 2 How to Determine Standard Exposure

Since the Silver Master is coated with silver-halide emulsion, its sensitivity may slightly vary from lot to lot. Before using a new lot, check its sensitivity.

Under-exposure may cause a thickened image or scumming on the background of the plate.

Over-exposure may cause a too thin image or lost image.

Correct exposure is essential for the high quality Silver Master SLM-R11 and SLM-F to deliver the best performance.

Refer to the Silver Master Technical Guide.

① The CP-324S is supplied with a test chart and a standard print sample. Make an exposure of the test chart using the photographing procedure stated in 8.1 and compare it with the standard print sample.

② Check the gray scale in the exposure (reproduction) of the test chart, and adjust the exposure level until the standard exposure is produced.

(Standard exposure means here the exposure (reproduction) where the minimum noticeable silver deposit is seen in the 12th step of the gray scale as in the supplied sample.)

The exposure control setting (between 0 – 99) used when the standard exposure was produced is the standard exposure control setting.

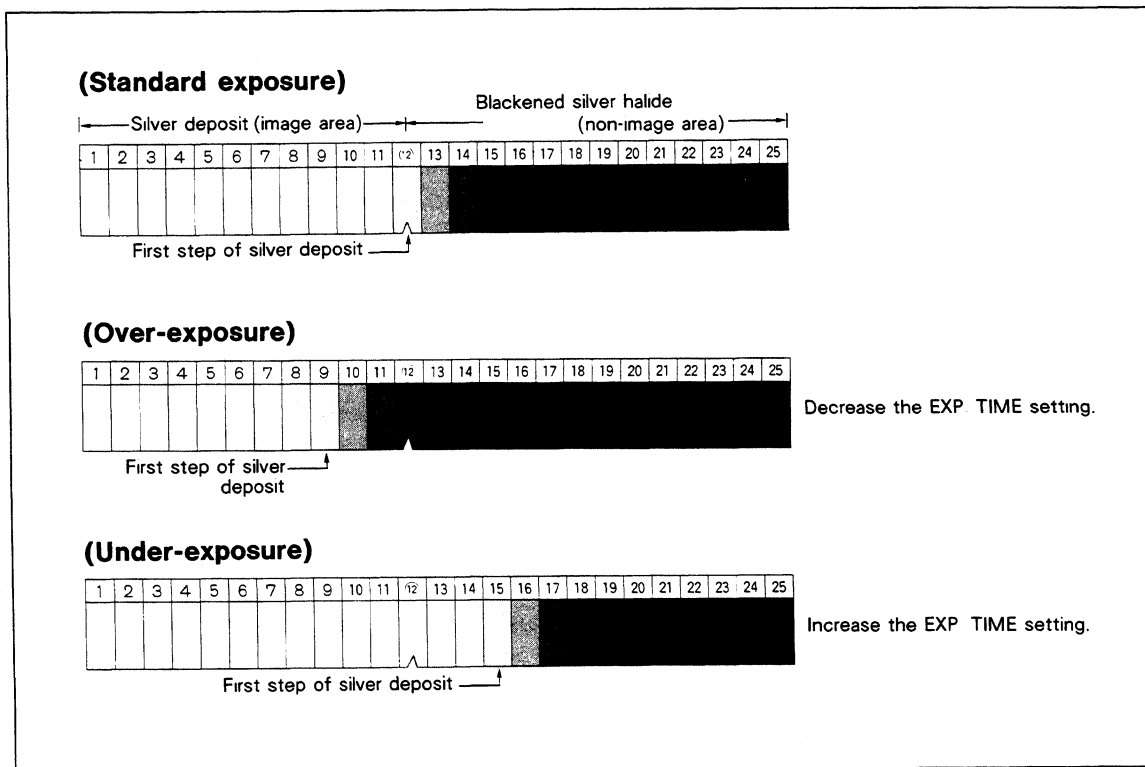

NOTE : The standard print sample may fade with time. Store it in a drawer or dark place.

8 - 3 How to Determine the Optimum for the Copy

- ① The optimum exposure level (control setting) varies according to the type of the original copy being used.
- ② The optimum exposure level (control setting) differs according to the users' printing conditions (press, printing paper, ink, etc.) .

The table below shows the recommended exposure control settings for various types of copies. Each user should find the best exposure control setting for each copy depending on the individual printing conditions.

Recommended Exposure Control Settings For Various Copies

Copy		Increase/Decrease from Standard Setting
State	Type	
Letters or lines are too thin or blurred.	Written with pencil	0 to -20% Decrease but not to the extent that non-image area becomes whitish.
	Duplication	
Letters are too thick and rough, or there is a darkish back-ground.	Photocomposition	-10 to +20%
	Typewritten	0 to +30% (Increase)
	Halftone	+20 to +30% (Increase)













9. MAINTENANCE

The routine maintenance procedure outlined below is necessary to maintain continued satisfactory operation of the CP-324S.

9 - 1 Maintenance Mode

The maintenance mode is used to check operation of the components or when carrying out routine maintenance.

NOTE: The maintenance mode is used when the machine is on "STAND BY."

Check Item	Key Operation	Purpose & Operation
① Independent cutter movement	 +  Press the numeric key  while holding the counter key depressed.	<u>Cutter operation check</u> <ul style="list-style-type: none"> The cutter should move forward (in cutting direction) till it reaches the return sensor, and then return to the original position.
② Independent copy holder travel NB) Set the nip roller to 	 +  Press the numeric key  while holding the counter key depressed. Turn off the main switch.  +  Turn on the main switch. Press the numeric key  while holding the counter key depressed.	<u>1. Halogen lamp replacement</u> <u>2. Cleaning the copy glass plate</u> <ul style="list-style-type: none"> The holder should move to the left and stop when it touches the end sensor. The holder should return (right) to the original position. As long as the end sensor is not touched, the holder can be returned by turning the power switch off and back on.
③ Lighting of the halogen lamp	 +  Press the numeric key  while holding the counter key depressed.	<u>Confirming the lighting of the lamp</u> <ul style="list-style-type: none"> The lamp should light for 5 sec and automatically go out.

9 - 2 Routine Maintenance

9 - 2 - 1 Processor

① Change of processing solutions

One fill of activator or stabilizer is capable of processing 500 plates of B4 format, or 250 plates of A3 format, and their nominal useful life is 4 weeks. When one of these two limits is exceeded (life span or processing capacity), the solution must be changed whether the other limit has been exceeded or not.

② Cleaning the processing tank unit and conveyor unit

As many plates are processed, silver, paper powder or chemicals from the plates can stick to the tanks, and scratch or stain the plate emulsion. Be sure to clean the tank unit and conveyor unit when changing the processing solutions.

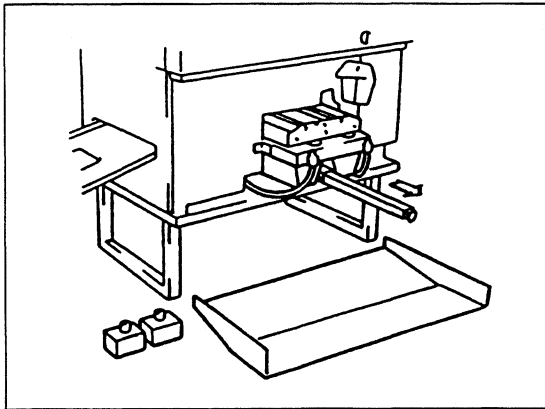

① Turn off the main switch.

② Remove the front cover of the machine and move the whole processor slightly forward.

③ Pull out the stand leg as illustrated, and place it upright on the floor.

④ Take out the replenisher containers.

⑤ Position a draining bucket and extend the drain hose into the bucket.

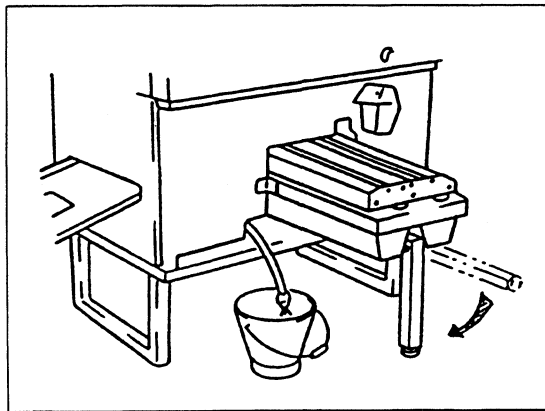

⑥ After the processing tanks are drained completely, put the drain hoses back in their original position.

⑦ Disconnect connector J8.

⑧ Pull out the whole processor and move it somewhere convenient for cleaning.

⑨ Remove the conveyor unit from the tank unit.

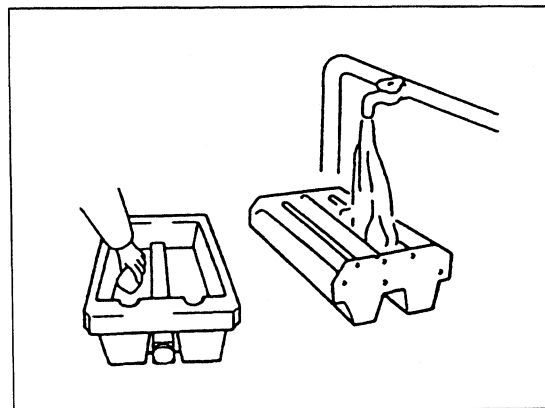

⑩ Wash the tank unit and conveyor unit thoroughly.

Carefully wipe off any sediment with a damp cloth or sponge.

—CAUTION—

As the rollers of the conveyor unit are not heat-resistant, use water of less than 40°C. No detergent or polishing compound must be used on them.

9 - 2 - 2 Replacement of the cutter blade (knife)

The cutting capacity of a cutter blade is approx. 300 plates (about two 75m rolls) . Replace the blade at least once a month regardless of the number of cuts made.

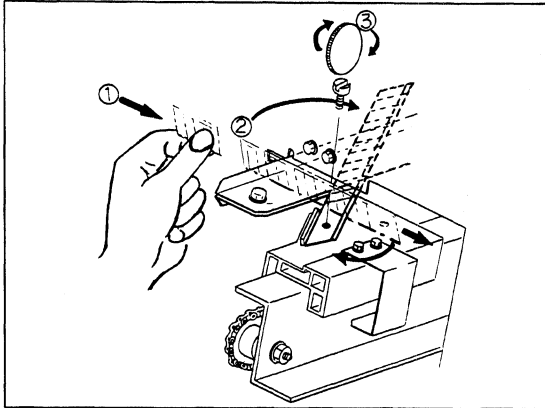





- ① Turn off the main switch.
- ② Remove the front cover.
- ③ Remove the cover of the cutter assembly.
- ④ A commercial NT cutter blade is used. Take care not to injure yourself with its cutting edge. The blade edge length should be 85 mm .
- ⑤ Tighten the setscrew with a coin or the like, placing the back of the blade against the guide.
- ⑥ Turn on the main switch, and check the cutting operation with the maintenance mode. (Press  + **1** .)

9 - 2 - 3 Replacement of the halogen lamp

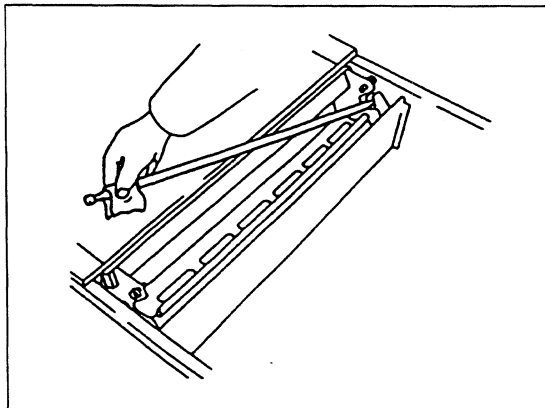
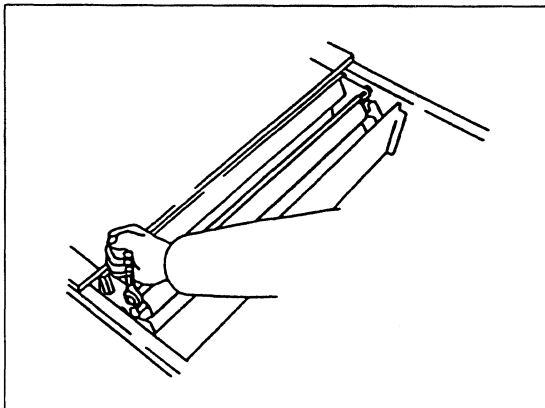
The machine uses a 80V, 650W halogen lamp as the light source.

Prior to replacing the lamp with a new one, never fail to make sure that the lamp and the reflector have cooled.



- ① Turn the nip roller lever to ("free" position) .
- ② Set the "STAND BY" mode and move the copy holder to the left. (Press  + **2** .)
- ③ Turn off the power switch.
- ④ Unscrew (M4 × 4) and remove the top cover at the master magazine side.
Remove the reflector fastening screws (M4 × 2) .
- ⑤ Hold the lamp with a clean dry cloth or in your gloved hands.
Never hold it with bare hands.
Take care not to smear or fingerprint the lamp surface.
Such stains could cause an uneven illumination. If the lamp should be fingerprinted or smeared, apply a very small amount of commercial alcohol to lens paper (available at general camera shops) and lightly wipe with the lens paper.
- ⑥ After the lamp has been replaced, turn on the main switch.
- ⑦ Set the STAND BY mode and check to see if the new lamp lights up normally.
(Press  + **3** .) The lamp should light for 5 sec.
- ⑧ Return the reflector to the original position and replace the top cover as it was.
- ⑨ Return the copy holder to the original position.
(Press  + **4** .)
- ⑩ Cancel the STAND BY mode.

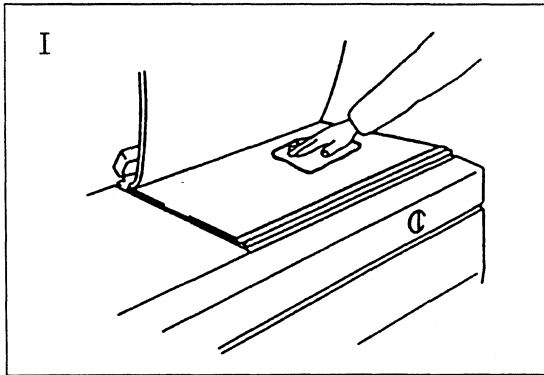

9 - 2 - 4 Care of the copy glass plate

As the copy glass plate is liable to be stained by dust or fingermarks, never fail to carry out a daily start-up check. If stained, wipe it with a soft cloth using a glass cleaner (available on the market) , taking care not to leave any cleaning agent behind.



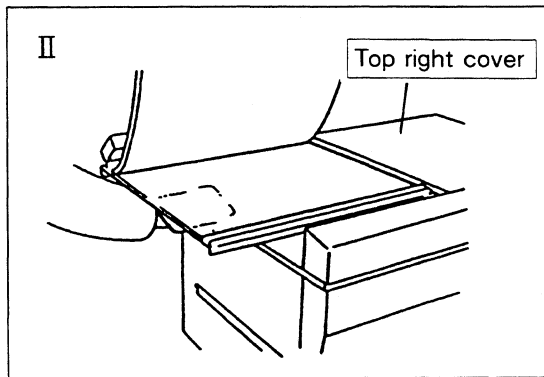



- ① Open the copy cover to clean the upper side of the glass plate.

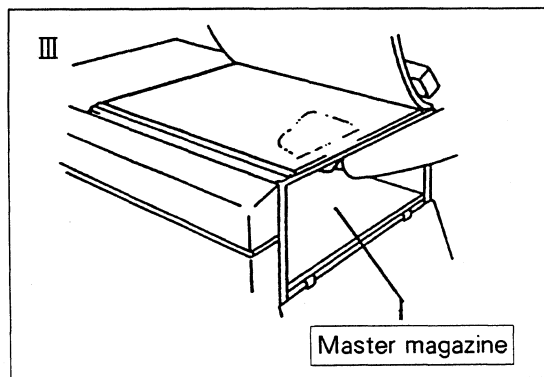

- ② To clean the left underside of the glass plate, move it to the left while the machine is on STAND BY using the following key operation sequence :  +  + 

- ③ Remove the top right cover and then take out the partition (removable) in the direction of the arrow.
(See Fig. IV.)



- ④ Turn the power off and then back on. To clean the right underside of the glass plate, move it to the right with the machine on STAND BY using the following key operation sequence :  +  + 

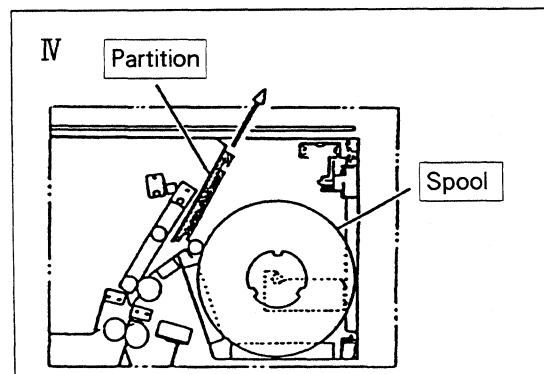

- ⑤ Move the copy glass plate to the left and replace the partition and top right cover.

9 - 2 - 5 Lens-mirror section

The lens and mirrors do not become dirty so easily since they are located inside the machine. Over time, however, their optical performances may deteriorate due to dust or other matter. Therefore, they should be carefully cleaned as follows.

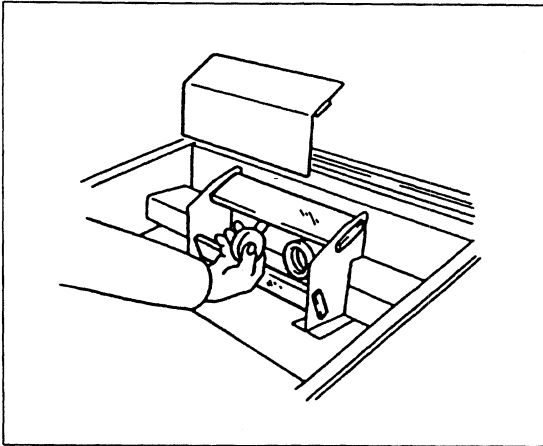

- ① If the top cover on the left of the copy holder is removed, the lens and reflection mirror appear.
- ② The lens and mirrors should be gently dusted off every month using an airbrush.
- ③ If they are extremely dirty, lightly wipe them with lens paper (available at general camera shops) moistened with a very little industrial ethyl alcohol. (This is available on the market) .

9 - 2 - 6 Dryer

If the rollers in the dryer are dirty, the emulsion of the material can be scratched or stained.

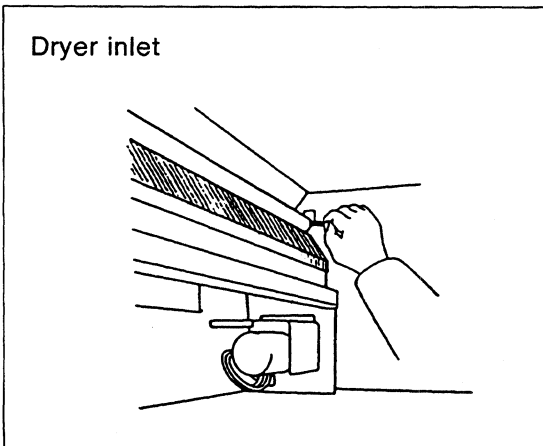

- ① Turn off the main switch.
- ② Remove the processor from the machine.
- ③ Unfasten the upper roller counter spring located at the dryer inlet.

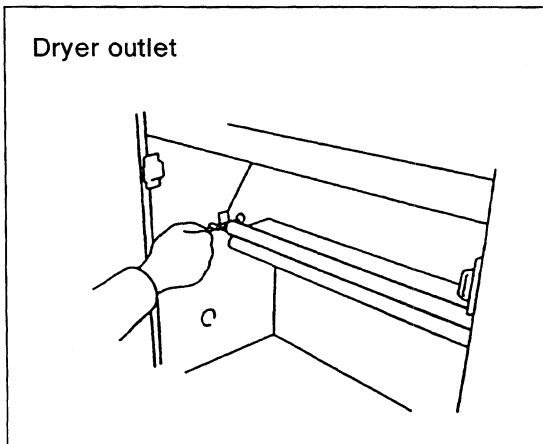

- ④ Remove the left side cover from the machine, and unfasten the upper roller counter spring located at the dryer outlet.
- ⑤ Wipe off the rollers with a moistened cloth.
- ⑥ Put the rollers back in place and fasten the counter springs.

9 - 3 Lubrication

As a rule, lubricate the parts shown below once a month, though the required frequency of lubrication depends on the frequency of operation.

NOTE : For lubricating oil, use SHELLTHRUS #27 or equivalent.

Apply the thinnest possible coating of oil.

① Copy rail

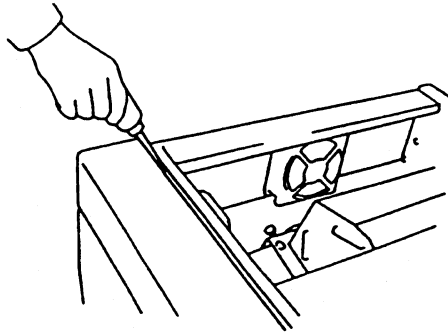

② Cutter chain

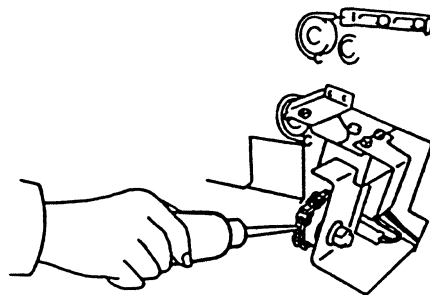

③ Processor
Dryer roller interlocking chain

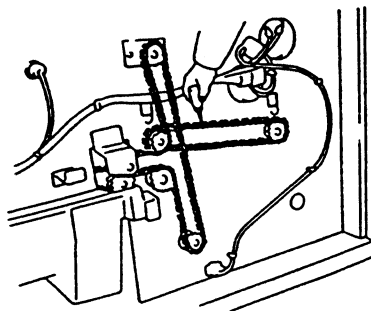

9 - 4 Order of Parts

The machine incorporates various kinds of parts. Some of them can be installed easily by the customers and others can be installed only by trained service personnel.

When ordering, please let us know the following :

- ① Whether parts only are needed or whether both parts and installation (replacement) service are needed.
- ② The information given in the certificate or the nameplate of your machine.
 - 1) MODEL : CP-324S
 - 2) MFG NO.
- ③ Descriptions of parts and quantities required, date of delivery, etc.

NOTE : • Specifications are subject to change without notice.

- The manufacturer assumes no responsibility for any trouble caused by any modification made to the machine by the user or by the use of another company's equipment or parts on the machine without the manufacturer's approval.

10 . TROUBLE SHOOTING

10 - 1 Error Messages

If an error message appears, it means that the machine is in trouble. Turn off the main switch, allow at least 5 seconds, then turn it back on, and retry operation. If the machine still does not work normally, contact us.

Display	Error	Check Point
ERR1	Although the cutter moves forward (in cutting direction) and touches sensor, it does not stop by the sensor, but turns back to the original position by mechanical collision.	<ol style="list-style-type: none"> ① Cutter return sensor PS6 is defective. Replace it. ② Check for a connector contact defect or discontinuity.
ERR2	After cutting, although the cutter returns, it stops not because the original position sensor works but because the motor stops running.	<ol style="list-style-type: none"> ① Cutter original position sensor PS5 is defective. Replace it. ② Check for a connector contact defect or discontinuity.
ERR3	Upon pressing,  the copy holder moves but stops not at the prescribed position but at end sensor PS4.	<ol style="list-style-type: none"> ① Master feed sensor PS2 is defective. Replace it. ② Check for a connector contact defect or discontinuity. ③ The encoder on the left as viewed from the machine rear (non-operation) side is not in place, or is rotating abnormally.
ERR4	In auto double exposure, after the 1st exposure, the copy holder should return to a position which differs depending on the input master and copy lengths. If the holder fails to complete the return within a specified time period, it stops.	<ol style="list-style-type: none"> ① Copy holder return sensor PS1 is defective. Replace it. ② Check for a connector contact defect or discontinuity. ③ The encoder in the middle as viewed from the machine rear (non-operation) side is not in place, or is rotating abnormally.

10 - 2 Cutter Malfunction

If the material is delivered uncut, the following message appears on the display. Check the points stated below.

Display	Error	Check Point
CHK CUTTER	The exposed material comes out of the machine without being cut.	<ol style="list-style-type: none"> ① Check for a broken blade. ② Do the check as outlined in 10. 1 for ERR2.

NOTE · For cutter blade replacement, refer to 9 - 2 - 2.

11 . OPTIONAL ACCESSORIES

Automatic Replenishment Device :

This system automatically replenishes the developing and stabilizing tanks with activator replenisher and stabilizer replenisher respectively to ensure a prolonged service life for the solutions in the tanks.

11 - 1 Component Location

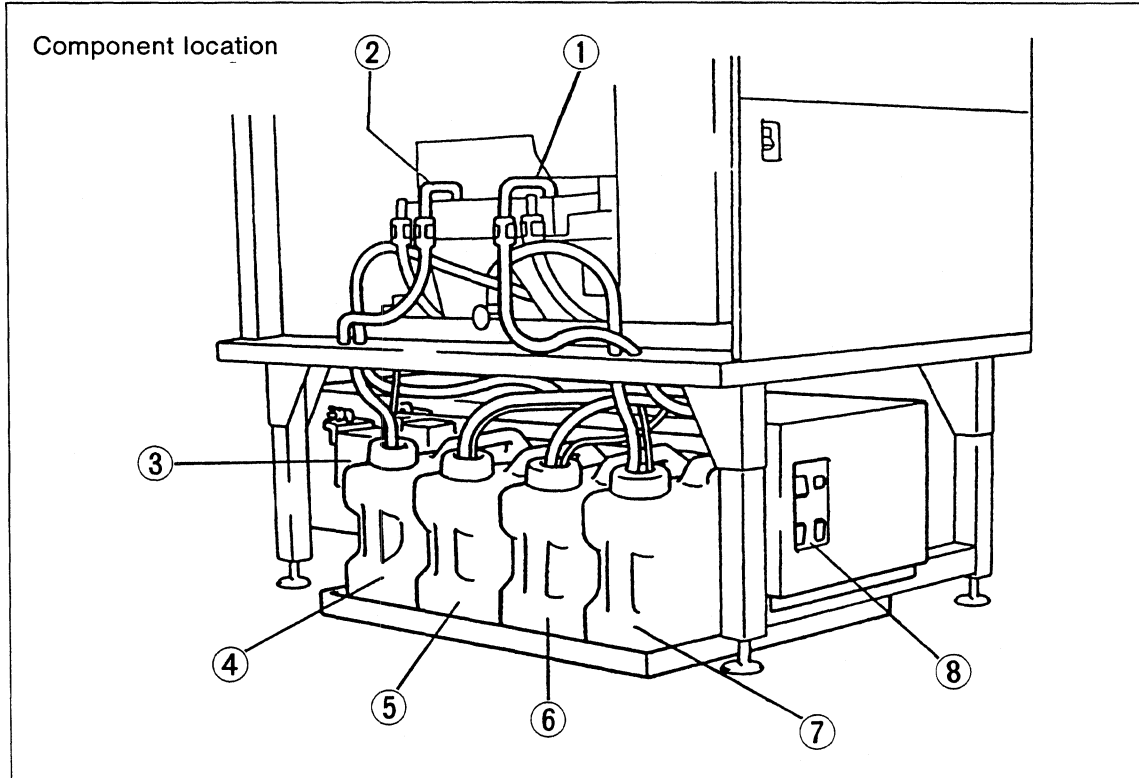

- ① Activator replenisher hose
- ② Stabilizer replenisher hose
- ③ Replenishing pump
- ④ Stabilizer drain container
- ⑤ Stabilizer replenisher container
- ⑥ Activator replenisher container
- ⑦ Activator drain container
- ⑧ Control panel

11 - 2 Control Panel

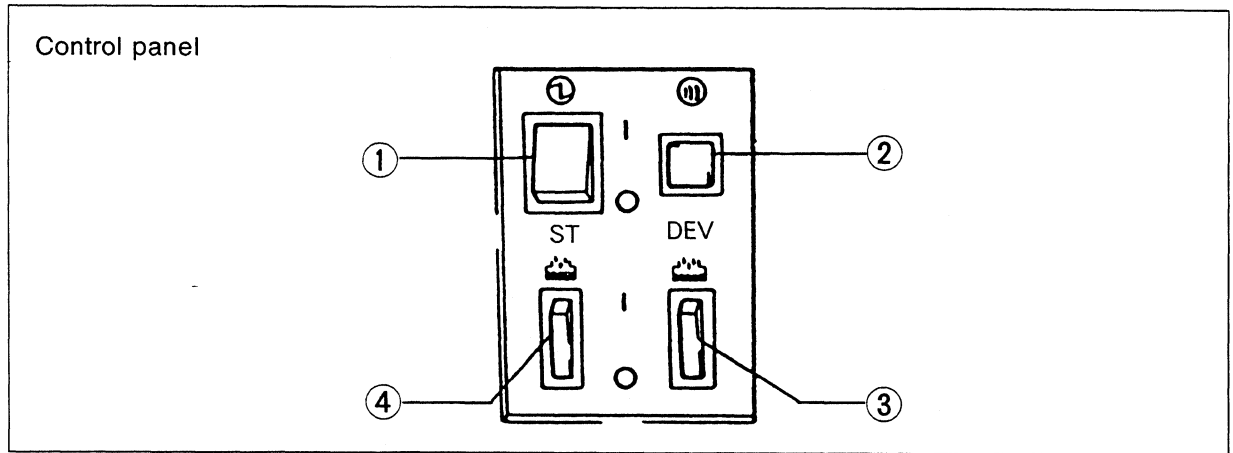

- ① Power switch
When this switch is turned on, the control circuit is activated and the device is ready for replenishment.
- ② Buzzer cut switch
When the replenisher or solution drain container sensor is working, the buzzer sounds ; the buzzer can be stopped by pressing this switch.
- ③ Activator manual replenishment switch
This switch is held depressed while replenishment is being done.
- ④ Stabilizer manual replenishment switch
This switch is held depressed while replenishment is being done.

11 - 3 Operating the Replenishment Device, and Changing Replenishment Time

11 - 3 - 1 Automatic replenishment mode

Each time the cumulative area of processed material calculated from the preset roll width and master length reaches 1m^2 , a replenishment of approx. 50cc is made (standard replenishment time 7 sec).

- Replenishment starts once the material has completely entered the developing tank, and the start key is invalid while the following message is on display.
"REPL IN WAITING"

The device is factory set at standard replenishment time "7 sec."
To change the replenishment time, proceed as follows :

① Press **A** while pressing  .

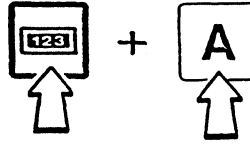

② "REPL TIME ?" and "07" appear on the display.

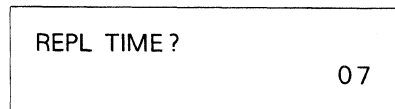

③ Enter the desired replenishment time using the numeric key pad.
(e. g. 8 sec.)



④ Press  to store it.









11 - 3 - 2 Initial replenishment mode

If the machine is out of use for a long period of time, the level of solution in the processor tank will fall due to evaporation.

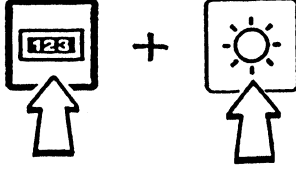
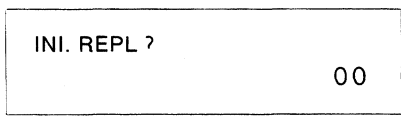
Initial replenishment is made automatically for the preset time, each time the machine is switched on, to maintain the proper level of solution.

To set or change the replenishment time, proceed as follows :

<p>① Press  while pressing  .</p>	
<p>② “INI. REPL ?” and “00” appear on the display.</p>	
<p>③ Enter the desired replenishment time using the numeric key pad. (e. g. 5 sec.)</p>	
<p>④ Press  to store it.</p>	

11 - 4 Control of Activator Level II

When the level of activator in the processor tank is below a certain level, the following message will appear on the display and the processing solution will be automatically refilled.

REPL IN
WAITING

If the level of solution does not rise even though replenishment has begun, this means that replenishment has stopped, and the following message (accompanied with the sounding of the buzzer) will appear on the display.

CHECK
PROCESSOR

Inspection Procedure

- ① Remove the processor cover.
- ② Slide the tank out towards you. Then make sure the anti-oxidation board moves up and down normally and the hose is properly connected and not split.
- ③ Put the cover back on the processor and check that replenishment has been properly made.

Please contact our service engineer if replenishment has not been made.

12. WIRING DIAGRAMS

CN1, CN23

PIN No.	WIRE No.	PIN No.	WIRE No.
線番	線番	線番	線番
1	PS	2	PS
3	PS	4	PS
5	3C0	6	3C1
7	3C2	8	3C3
9	3C4	10	3C5
11	3C6	12	3C7
13	3A0	14	3A1
15	3A2	16	3A3
17	3A4	18	3A5
19	3A6	20	3A7
21	3B0	22	3B1
23	3B2	24	3B3
25	3B4	26	3B5
27	3B6	28	3B7
29	T M	30	STSS
31	GND	32	GND
33	GND	34	GND

CN No.	1	2	3
線番	線番	線番	線番
CN 2	PSA	GND	
CN 5	E24	61	P24
CN 6	E24	62	P24
* CN 7	E24	63	
CN 8	E24	64	P24
CN 9	E24	65	P24
CN 10	E24	66	P24
CN 11	E24	67	P24
CN 12	E24	68	P24
CN 13	E24	69	
CN 17		73	
CN 18		74	
CN 19	E24	76	75
CN 20	E24	78	77

CN3

PIN No.	WIRE No.	PIN No.	WIRE No.
線番	線番	線番	線番
1	PSB	2	1A0
3	1A1	4	1A2
5	1A3	6	1A4
7	1A5	8	1A6
9	1A7	10	1B0

CN4

PIN No.	WIRE No.	PIN No.	WIRE No.
線番	線番	線番	線番
1	P24	2	P24
3	P24	4	E24
5	E24	6	E24
7	41	8	42
9	43	10	44
11	45	12	46
13	47	14	48
15	49	16	50
17	51	18	52
19	53	20	

表1)

CPU CN No.	行名
CN 1	CONTROL PANEL CN23
CN 2	SWITCHING REGULATOR SRI
CN 3	LIGHT CONTROL BOARD CN43
CN 4	RELAY BOARD CN30
CN 5	COPY BACK PULSE SENSOR PS1
CN 6	MASTER FEED PULSE SENSOR PS2
CN 8	COPY O-P SENSOR PS3
CN 9	COPY END SENSOR PS4
CN 10	CUTTER O-P SENSOR PSS
CN 11	CUTTER END SENSOR PS6
CN 12	RELAY BOARD CN33
CN 13	DEV LEVEL SW RES1 J7
CN 17	REPLENISHER J1
CN 18	REPLENISHER J1
CN 19	MASTER END SENSOR PS2
CN 20	MASTER SEAM SENSOR PS8

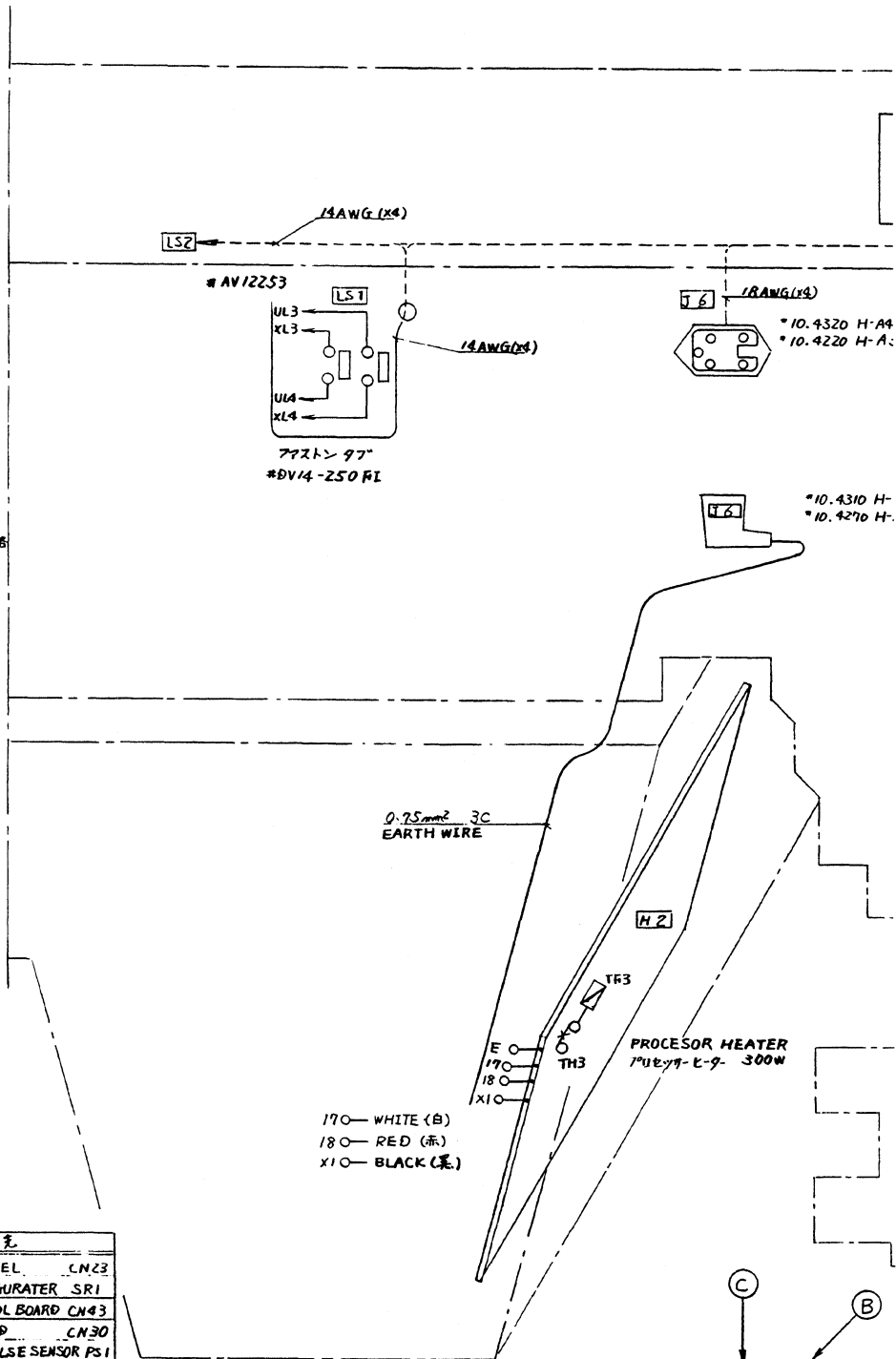

170— WHITE (白)
180— RED (赤)
X10— BLACK (黒)

(A)	DISTRIBUTING BOARD CONNECTION DIA. 配電盤結線図	HCM 31259
(B)	BACK VIEW CONNECTION DIA. 後部結線図	HCF 31648
(C)	TOP VIEW CONNECTION DIA. 上部結線図	HCE 31647
	WIRING SYSTEM DIA. 系統図	HCS 32315

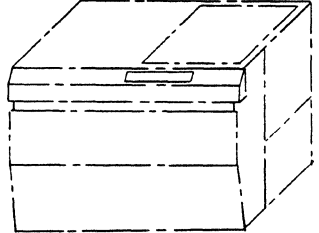

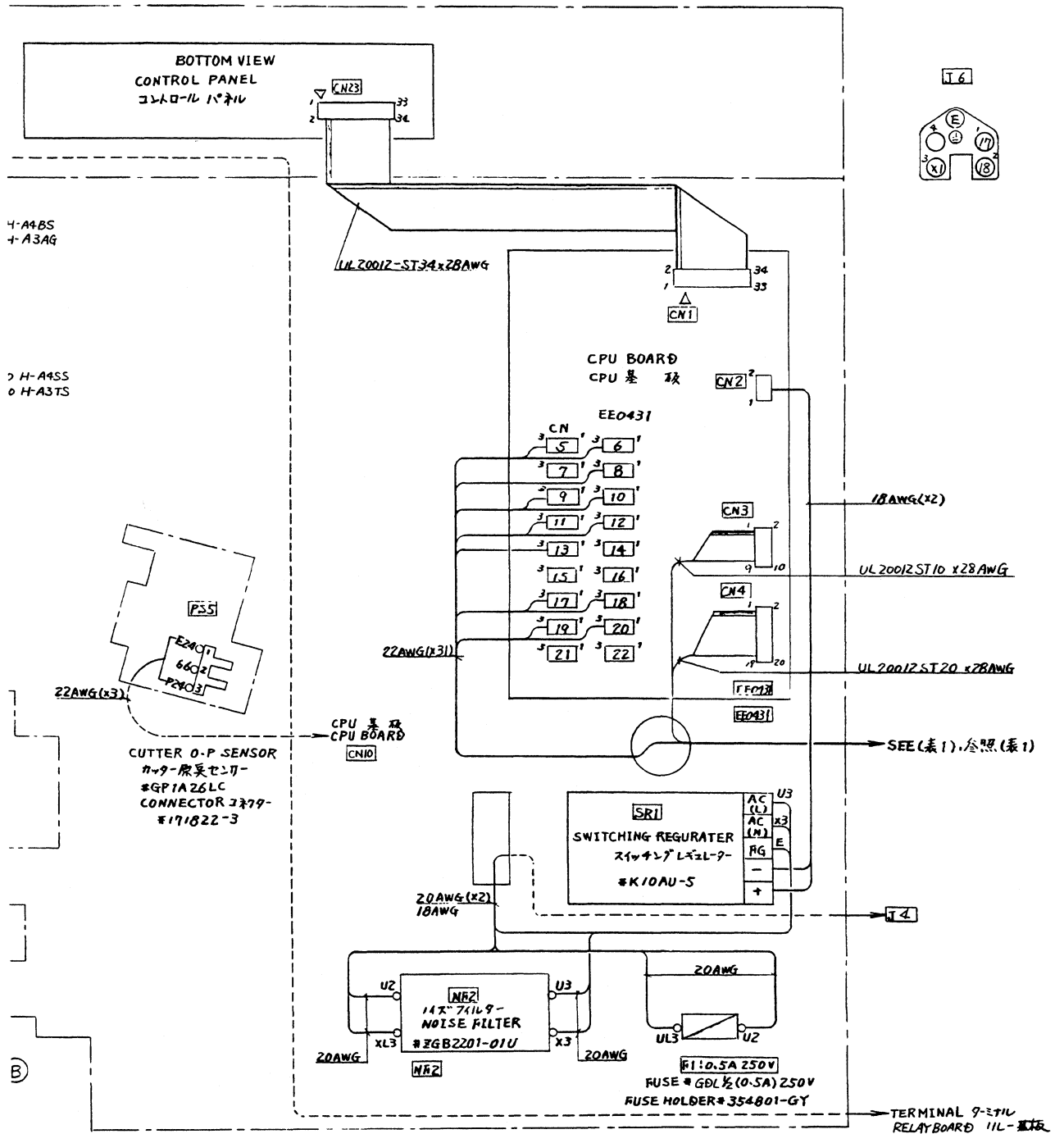

4-A4BS
4-A3AG

2-H-A4SS
0-H-A3TS

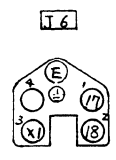

HEAT PROOF WIRE — UL1727 TETRAFLUOROETHYLENE WIRE
(耐熱線) (テフロン電線)

※ 14~18 AWG UL1015 105°C 600V

20~24 AWG UL1007 80°C 300V

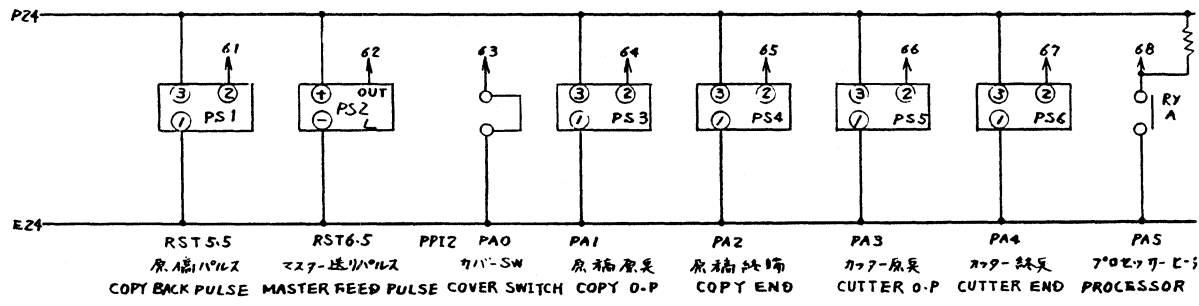
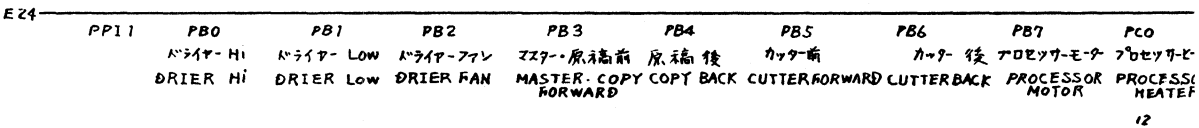
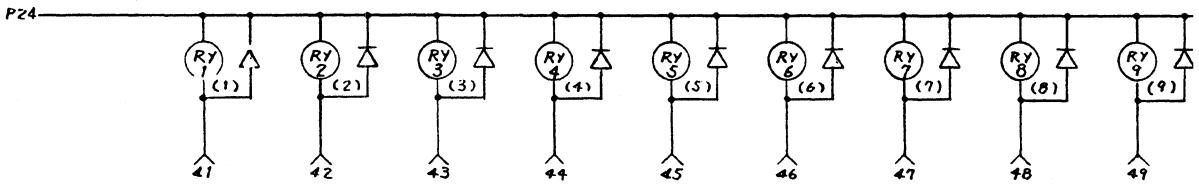
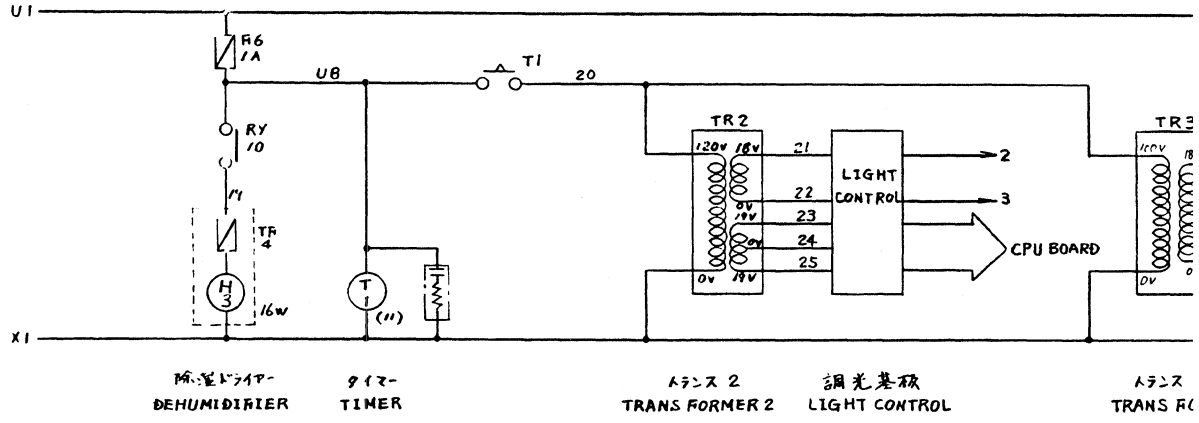
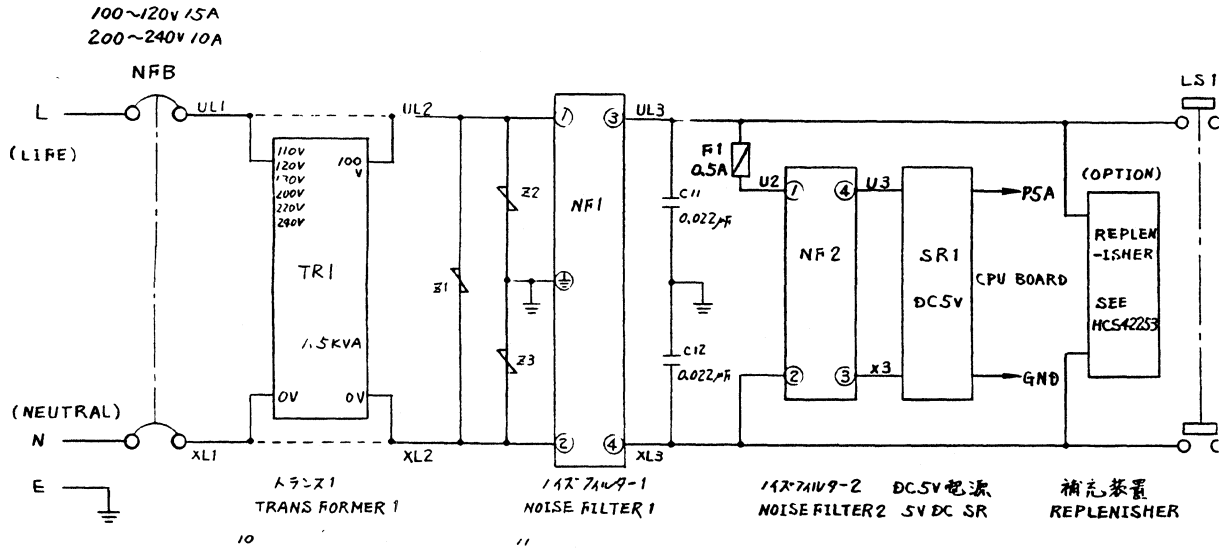

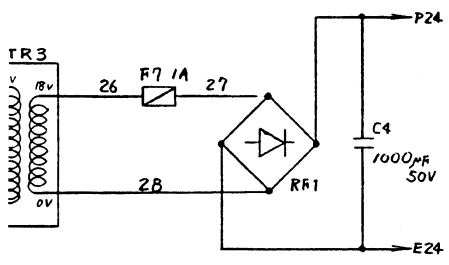
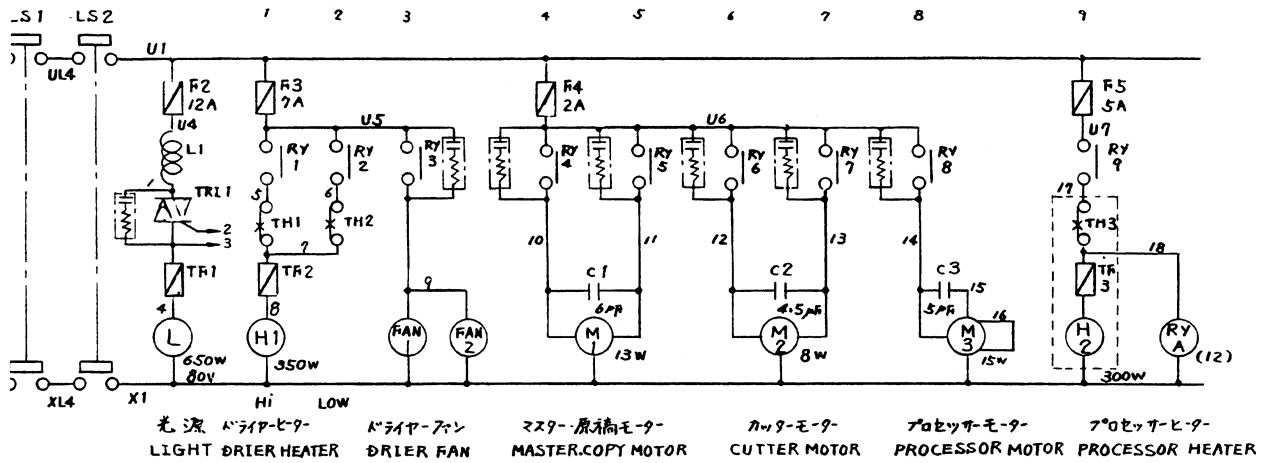

3 S FORMER 3 DC 24V 電源 24V DC

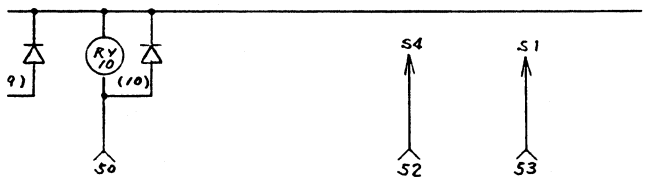

PC1 除湿ヒーター FSSOR DEHUMIDIFIER HEATER
 PC3 透過光源 TR. LIGHT
 PC4 補充ヒーター AUTO REPLENISHING

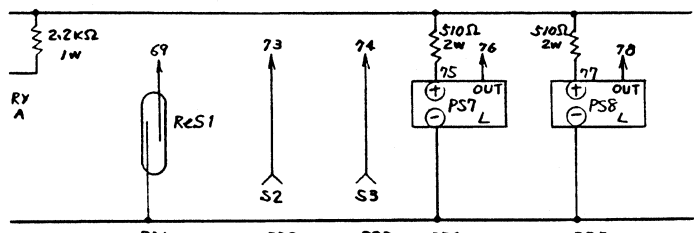

ヒーター DEV REPLENISHING REPLENISHING MASTER SEAM LEVEL ON O.K. END

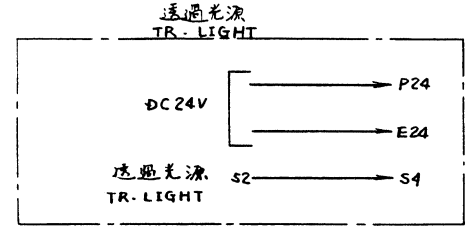
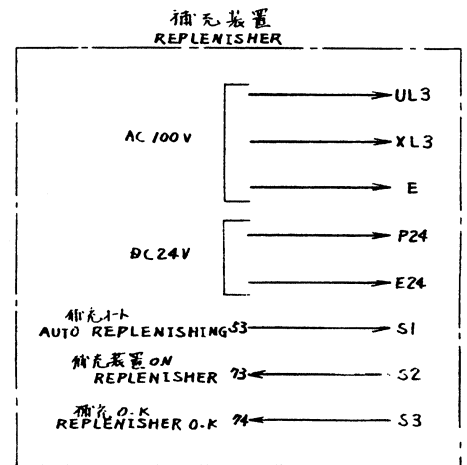

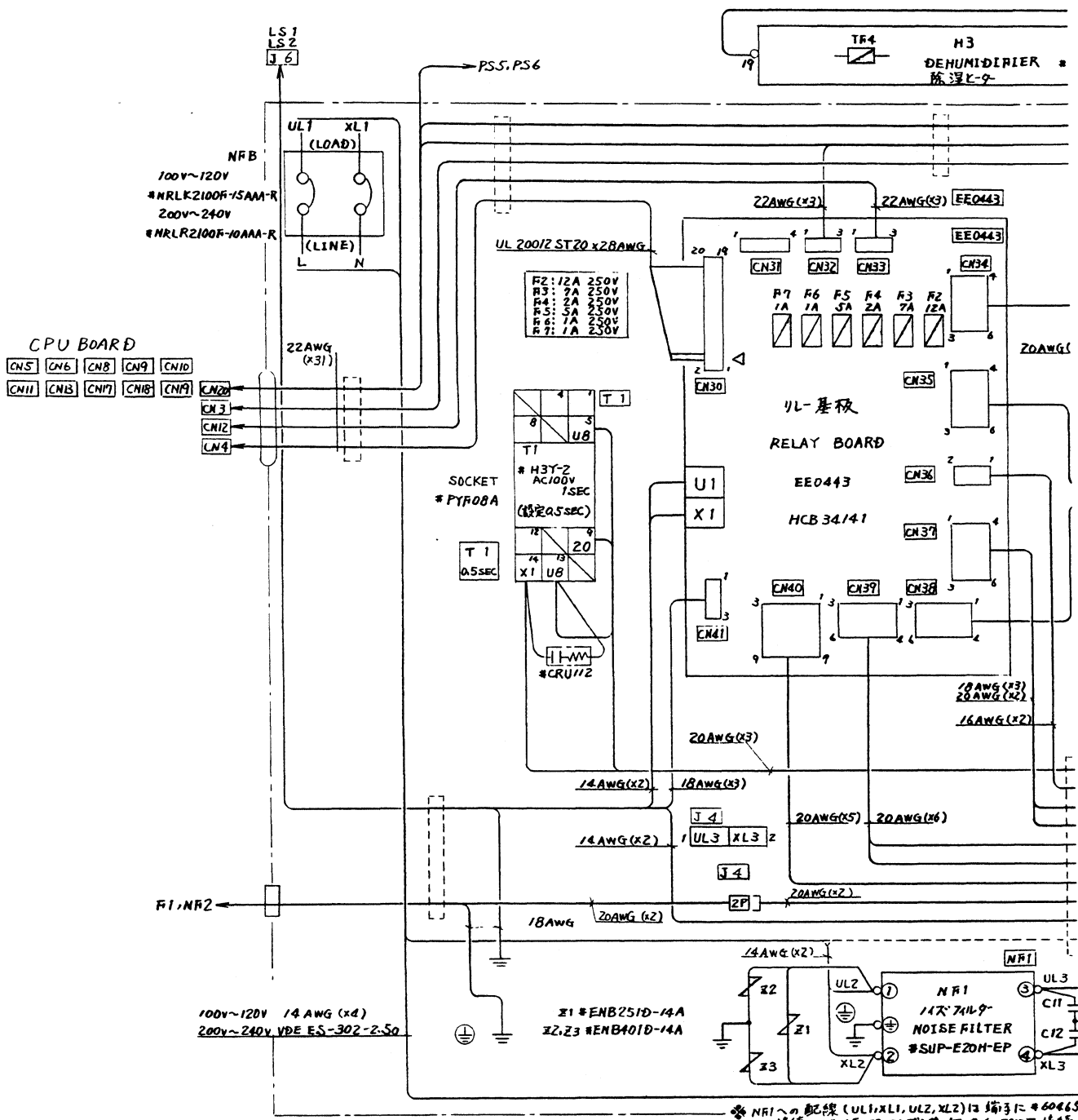

100V~120V 14AWG(x4)
200V~240V VDE ES-302-Z-50

Z1 #ENB251D-14A
Z2, Z3 #ENB401D-14A

* NFIへの配線 (UL1, XL1, UL2, XL2) は端子に #60465
にて接続。セムラップ・コンデンサはモーターにて接続。

RELAY BOARD 1/4-基板

LIGHT CONTROL BOARD

CN No.	PIN No.	WIRE No.	行先	CN No.	PIN No.	WIRE No.	行先	CN No.	PIN No.	WIRE No.	行先	CN No.	PIN No.	WIRE No.	行先	CN No.	PIN No.	WIRE No.	行先								
CN 30	1~3	P24	CPU CN 4	CN 31	1	E24	J 1	CN 35	1	U4	L1	CN 38	1	12	C2	CN 40	1	12	M2	CN 42	1	23	TR 2				
	4~6	E24			2	S1			2	2	TRI 1		2	11			2	19			2	24					
	7	21			3	S2			3	3			3	10	C1		3	19			3	25					
	8	42			4	P24			4	4			4	13	C2		4	13	M2		4	9					
	9	43			1	E24			5	2	CN44		5	14	C3		5	19	H3		5	21					
	10	44			2	S3			6	3			6	15			6	X1			6	22					
	11	45			3	P24			1	3	L		1	10			7	X1	M2		CN 43	1~10		CPU CN 3			
	12	46			1	E24			2	X1	H1		2	11	M1		8	X1	H3			CN 44		1	2	RELAY BOARD	
	13	47			2	68			1	5	H1		3	X1			9	X1						CN 35	2	3	
	14	48			3	P24			2	6			4	15			1	17	H2								
	15	49			1	26			3	9	PH1~3		5	14	M3		2	18									
	16	50			2	U8			4	X1	H1		6	X1			3	X1									
	17	51			3	U8			5	X1																	
	18	52			4	28			6	X1	PH1~3																
	19	53			5	X1			TR3																		
	20				6	X1			T1																		

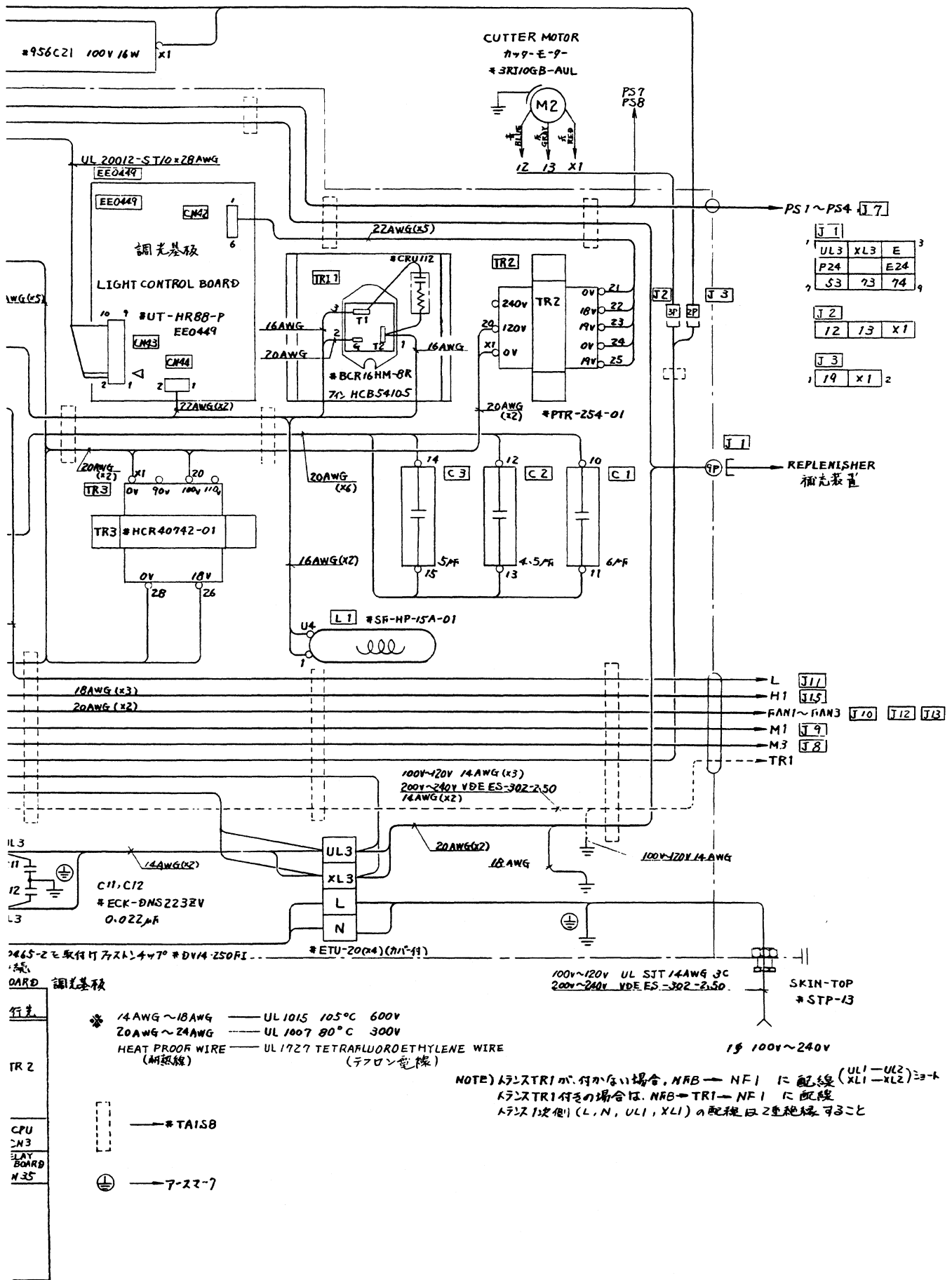

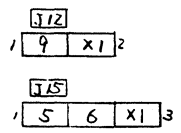
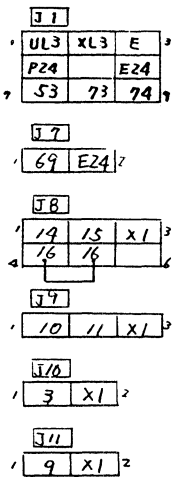
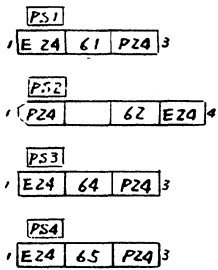

* 線番16の流り線と
X1側にて行儀の

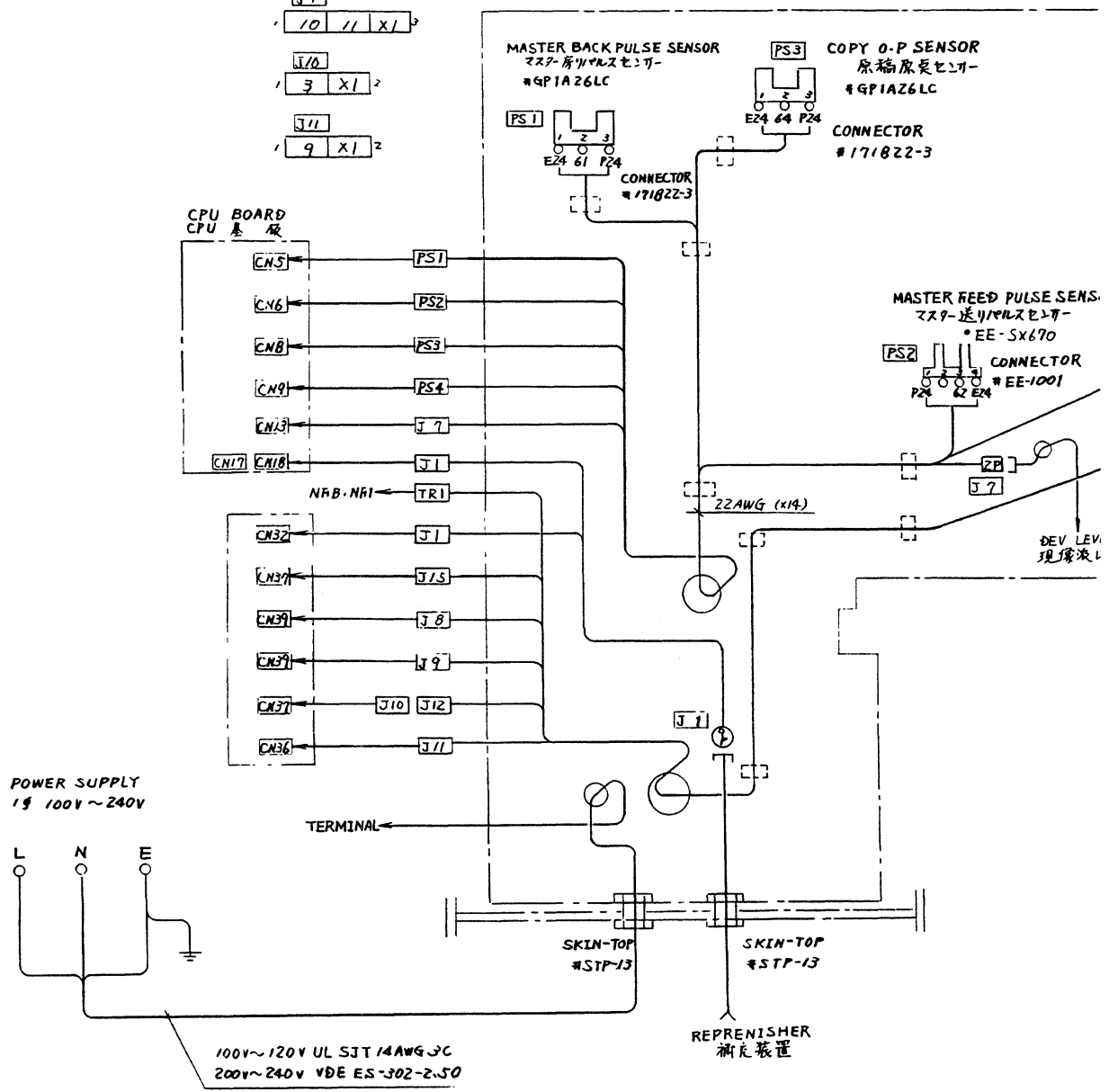

POWER SUPPLY
1φ 100V~240V

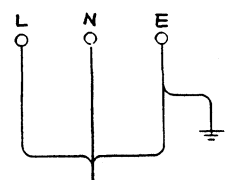

100V~120V UL SJT 14AWG J/C
200V~240V VDE ES-302-2.50

[---] #TA15B

* 14~18 AWG UL 1015 105°C 600V

20~24 AWG UL 1007 80°C 300V

HEAT PROOF WIRE — UL 1727 TETRAFLUOROETHYLEN (フロン)

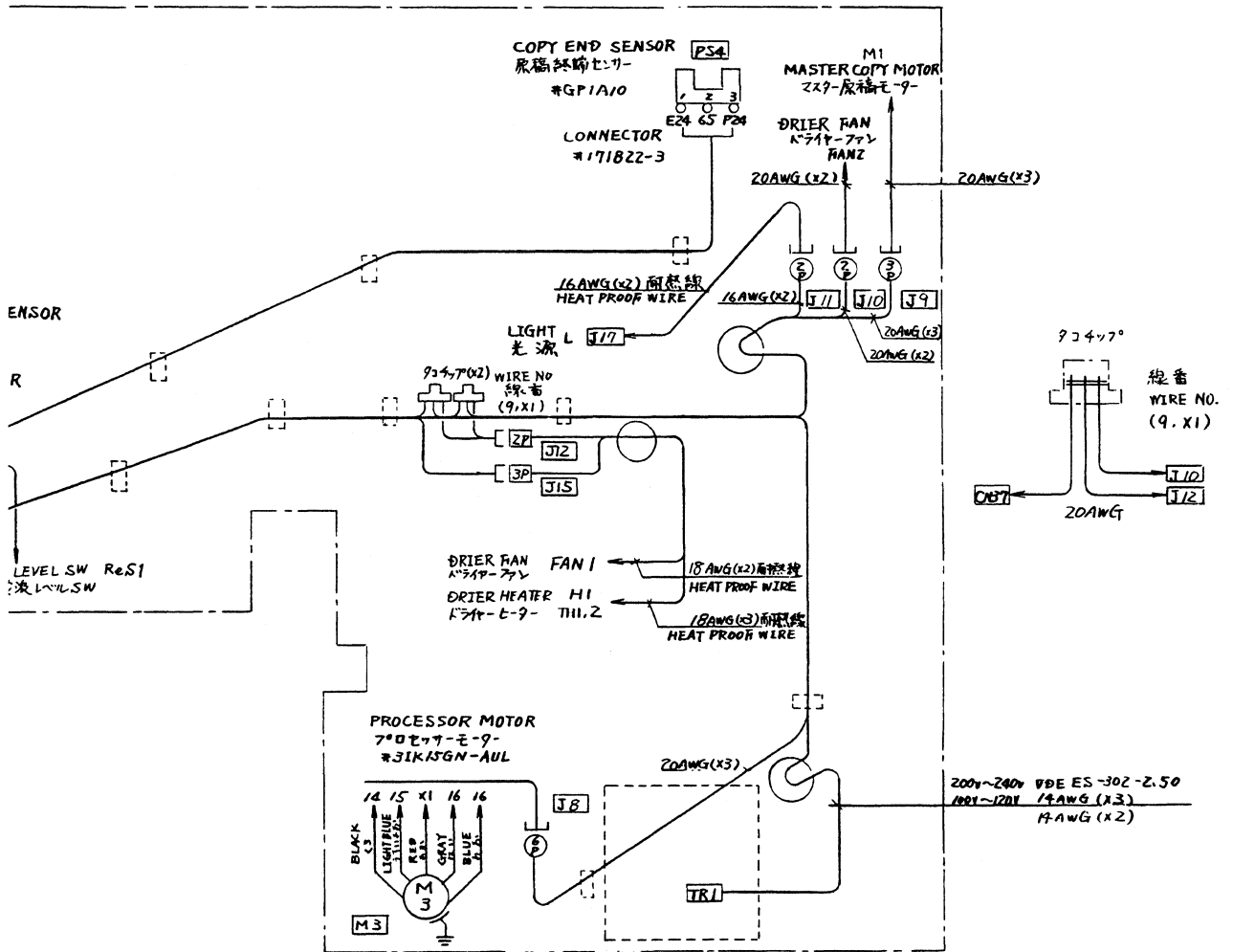

LENE WIRE
 (配線)

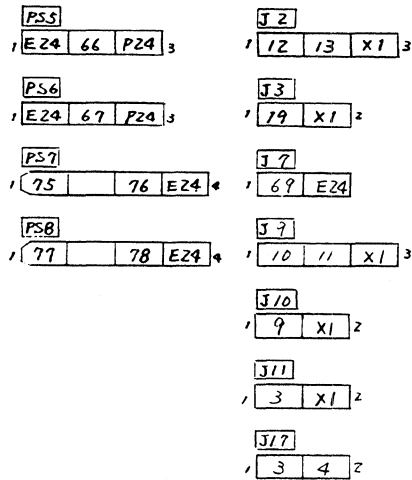

200V~240V VDE ES-302-2.50
 100V~120V 14AWG (x3)
 14 AWG (x2)

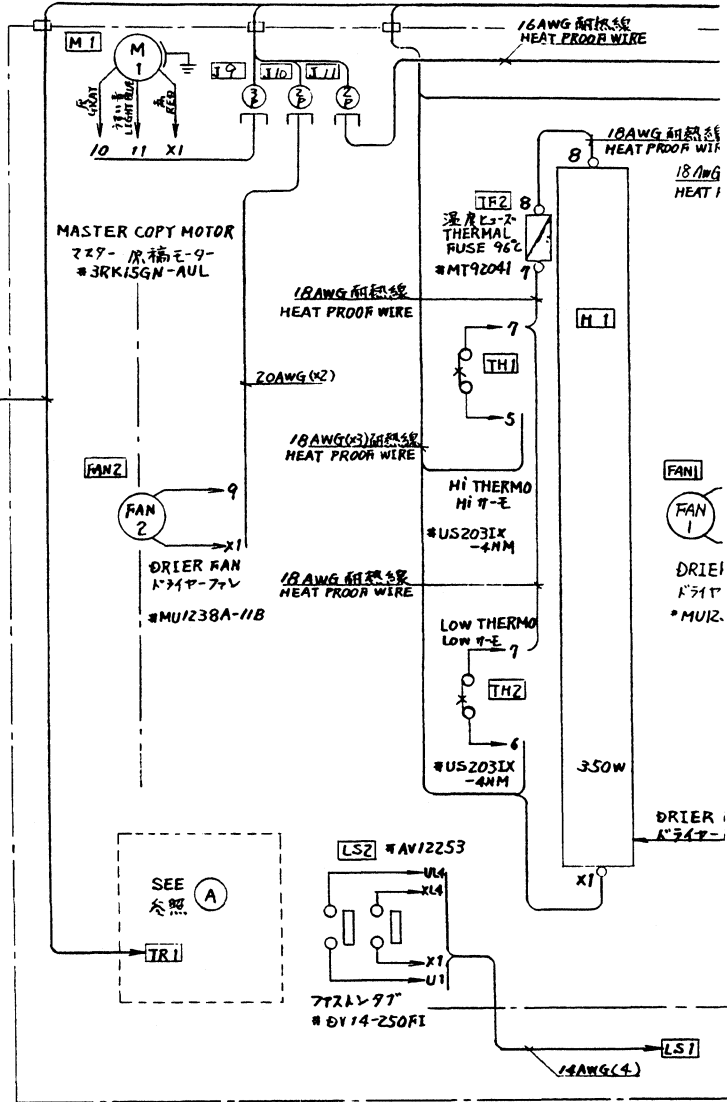

CONNECTOR No. コネクタ No.	RELAY BOARD CN No. リレー基板 CN No.
J2	CN 40
J3	CN 40
J7	CPU基板 CN 13
J9	CN 39
J10	CN 37
J11	CN 36
J12	CN 37
J15	CN 37

SENSOR No. センサー No.	CPU BOARD CN No. CPU基板 CN No.
PS 5	CN 10
PS 6	CN 11
PS 7	CN 19
PS 8	CN 20

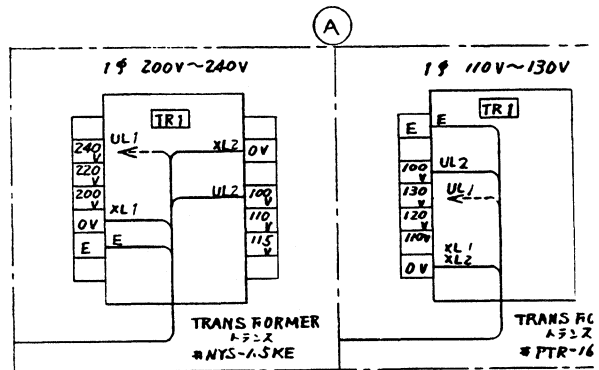

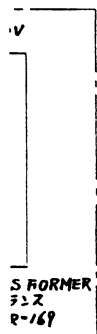
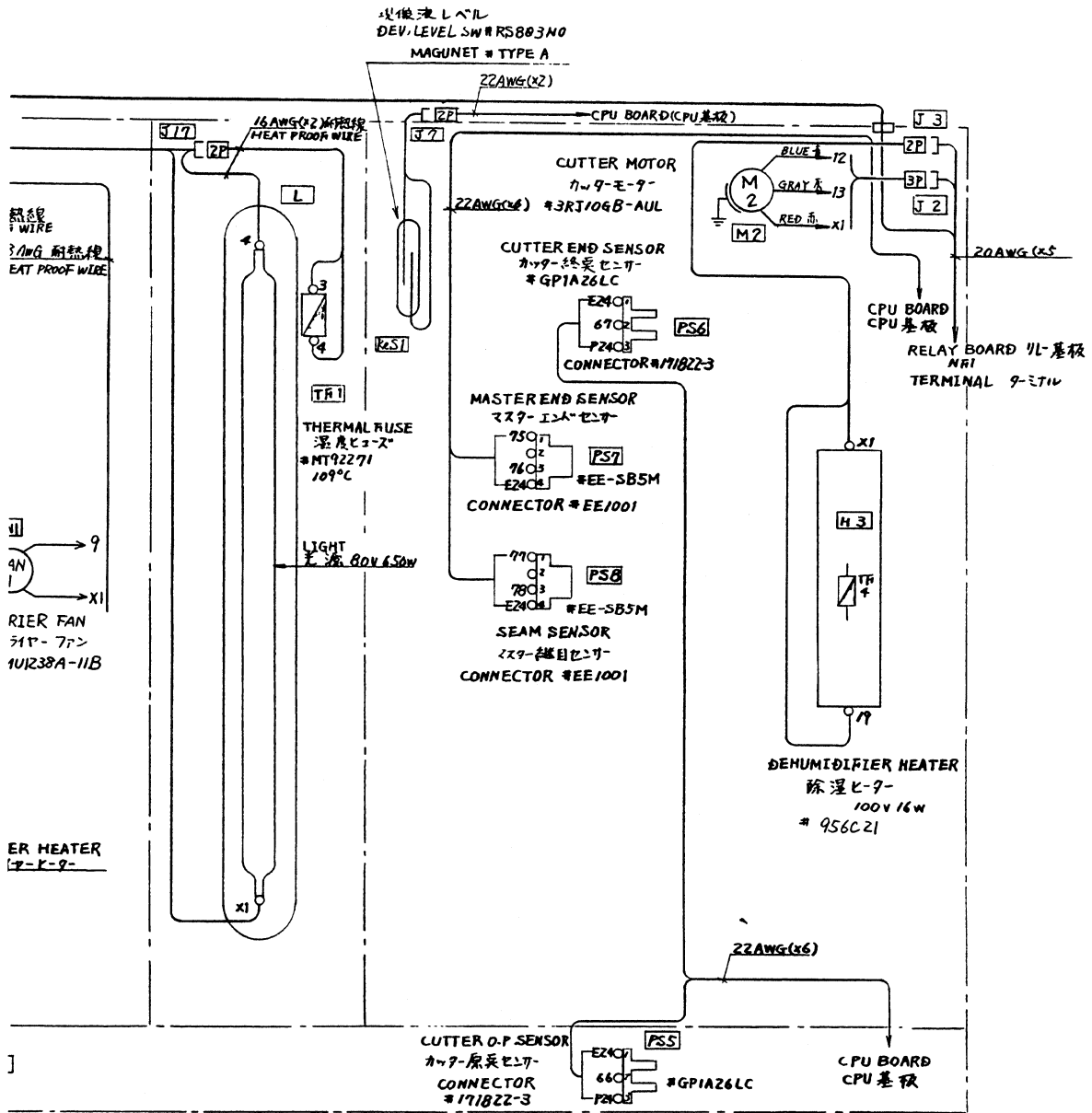

- 14~18 AWG — UL 1015 105°C 600V
- 20~24 AWG — UL 1007 80°C 300V
- HEAT PROOF WIRE — UL1727 TETRAFLUOROETHYLENE WIRE
 (耐熱線) (テフロンの電線)

mitsubishi paper mills limited

Head office: Shin-Nisseki Bldg., 7th Floor
No. 4-2, Marunouchi 3 chome, Chiyoda-ku, Tokyo, Japan
Tel. Tokyo(03)213-3742

Mitsubishi Paper International, Inc
520 Madison Avenue New York, N Y 10022 U S.A Tel 212-980-9644
Mitsubishi Paper GmbH:
Kennedydamm 19 4000 Dusseldorf 30 West Germany Tel.0211-4397-215
