

# Thermal Digiplate

***TDP-324***

Users Manual





# Introduction

Thank you for purchasing this THERMAL DIGIPLATER TDP-324 made by MITSUBISHI PAPER MILLS, LTD.

Read this manual carefully before using the Thermal Digiplate and become familiar with the installation and operation procedures.

Keep this user's manual at hand so that it can be referred to at any time during operation of the Thermal Digiplate.

This manual has been carefully prepared, however, if you find any mistakes, or have any questions, please let us know.

- ◆ If this manual is lost or damaged, promptly place an order for a new one from a distributor near you.
- ◆ If this Thermal Digiplate is transferred to another party, please attach this manual to the Thermal Digiplate.

■ **After receiving this product, check that:**

- It is the product that you ordered.
  - It has not been damaged during shipping.
  - All accessories are present.
- \* If a damaged or abnormal part is found, contact the distributor immediately.

Copyright © 2010: Mitsubishi Paper Mills Limited

The copyright for this entire manual belongs to Mitsubishi Paper Mills Limited.

Copying, reprinting, reproduction of this manual in whole or in part in any medium without our express consent infringes upon the copyright and the rights of the publisher.

The specifications in this document are subject to change without prior notice for product improvement. All brand and product names referenced in this document are trademarks or registered trademarks of their respective companies.



# Table of Contents

<b>Chapter 1</b>	<b>Safety Precautions.....</b>	<b>1</b>
1.1	Cautions for working environment and installation .....	2
1.2	Handling the Thermal Digiplate .....	3
1.3	Kind of warning labels and its attachment part .....	5
1.4	Handling plate before and after platemaking .....	6
<b>Chapter 2</b>	<b>Installation and Setup.....</b>	<b>7</b>
2.1	Unpacking and setup procedure.....	7
2.2	Unpacking .....	8
2.3	Checking the accessories .....	9
2.4	Names and functions of parts .....	10
2.4.1	Names of parts .....	10
2.4.2	Functions of parts.....	12
2.5	Connecting the power cable .....	13
2.6	Connecting the USB cable .....	14
2.7	Installing the plate tray .....	15
2.8	Setting the plate .....	16
2.9	Change Method of Flange Position .....	21
<b>Chapter 3</b>	<b>Use of Operation Panel.....</b>	<b>23</b>
3.1	Power switch.....	23
3.2	Operation panel.....	23
3.2.1	LED indications .....	24
3.2.2	Operation button.....	24
3.2.3	LCD indications .....	25
3.3	Explanation of the user mode.....	26
3.3.1	Selecting a plate size channel.....	27
3.3.2	Setting the plate size .....	28
3.3.3	Adjusting the print density .....	30
3.3.4	Checking the firmware versions .....	31
3.3.5	Setting the Head Cleaning Mode and Execution of Head Cleaning .....	32
3.3.6	Display of Plate Remains, and Reset of Plate Remains Counter .....	38
3.3.7	Display of Print Counter, and Reset of Print Counter.....	39
3.3.8	Setup of Plate Remains SW(on/off) .....	40
3.3.9	Execution of Platen Cleaning .....	41
3.3.10	Setting the Pinch Cleaning Mode and Execution of Pinch Cleaning .....	42
3.3.11	Display of accumulated print distance.....	46
3.3.12	Set up a print Interval .....	47
<b>Chapter 4</b>	<b>Daily Maintenance.....</b>	<b>49</b>

<b>4.1</b>	<b>Cleaning the parts inside the Thermal Digiplate</b> .....	<b>49</b>
4.1.1	Cleaning the thermal head .....	50
4.1.2	Cleaning the main pinch roller .....	52
4.1.3	Cleaning the platen roller .....	54
4.1.4	Cleaning the feeding pinch roller .....	56
4.1.5	Cleaning the cleaning rollers .....	58
4.1.6	Cleaning the image sensor .....	60
4.1.7	Cleaning the head position plate .....	62
<b>4.2</b>	<b>Cleaning the cover of the Thermal Digiplate</b> .....	<b>64</b>
<b>4.3</b>	<b>Cleaning the filters</b> .....	<b>64</b>
<b>4.4</b>	<b>Consumable parts</b> .....	<b>65</b>
<b>Chapter 5</b>	<b>Trouble shooting</b> .....	<b>67</b>
5.1	When an error message is displayed .....	67
5.2	Plate jam .....	68
5.3	When parts of image area are missing from the printed plate .....	71
5.4	Plate is not correctly detected .....	72
5.5	When power is off during printing .....	74
<b>Chapter 6</b>	<b>After-sales service</b> .....	<b>75</b>
<b>Chapter 7</b>	<b>Specification</b> .....	<b>77</b>
7.1	Basic specification .....	77
7.2	Outline figure .....	77

# Chapter 1 Safety Precautions

The purpose of this manual is to use this product safely.

Carefully read this manual and leaflets attached to the Thermal Digiplate and become familiar with the installation and operation procedures for safe use.

- ◆ This manual contains precautionary statements to prevent hazardous operations. The statements are categorized as follows so that you can better understand all safety precautions for this Thermal Digiplate.

## WARNING

**Indicates a hazardous situation that could result in death or serious injury if the Thermal Digiplate is handled incorrectly.**

## CAUTION

**Indicates a hazardous situation that could result in minor injury or property damage if the Thermal Digiplate is handled incorrectly.**

## Note

**Indicates causes of problem or conditions of working environment.**

- ◆ It is impossible for us to anticipate all hazards that may occur when the Thermal Digiplate is installed and used under various environmental conditions. Therefore, all possible warnings and cautions are not included in the user's manual, other leaflets or labels on the Thermal Digiplate. Should the Thermal Digiplate be operated or inspected in any way other than as indicated in the user's manual, you shall be responsible for the safety.
- ◆ The precautionary notes on how to use and inspect the Thermal Digiplate indicated in the user's manual and other leaflets are intended only for when the Thermal Digiplate is used for its originally specified purpose. Should the Thermal Digiplate be used for any purposes other than as intended in the user's manual, you shall be solely responsible for the safety.
- ◆ Never perform operations that are prohibited in the user's manual and other leaflets.

# 1.1 Cautions for working environment and installation

Pay attention to the following to use the Thermal Digiplate safely:

**⚠ WARNING**

Do not use the Thermal Digiplate in an environment with volatile substances, such as alcohol and thinner, or combustible gases.

**⚠ WARNING**

Do not put a vessel containing water, such as a vase, plant pot, cup, or any metallic article on this Thermal Digiplate. If water is spilt or a metallic piece enters the Thermal Digiplate, a fire or electric shock can occur.

**⚠ WARNING**

Do not cover the vent holes of the Thermal Digiplate. Doing so will not allow the heat to escape from the Thermal Digiplate, thereby causing a fire.

**⚠ WARNING**

Do not insert or drop a metallic or flammable article inside through any vent hole. Doing so can cause a fire or electric shock.

**⚠ WARNING**

Provide an electric outlet at an accessible place near this product.

**⚠ CAUTION**

Make sure that children do not touch the Thermal Digiplate and cables. Failure to do so can result in injury or electric shock.

**⚠ CAUTION**

Do not install the Thermal Digiplate in damp, dusty or sandy places, such as a bathing place, a bathroom, near a hot spring, on a road or by the side of a pool. Doing so can cause a fire, electric shock or failure.

**⚠ CAUTION**

Do not install the Thermal Digiplate on a shaky stand, inclined floor or any other unstable place. If so, it can fall or turn over and cause personal injury.

**Note**

Do not install the Thermal Digiplate in an area with an extremely low or high temperature. Do not install it, for example, in an area of a ski site or skating rink with a low ambient temperature or in an outdoor area where it will be exposed to direct sunlight and heat.



## 1.2 Handling the Thermal Digiplate

Pay attention to the following warnings and caution when handling the Thermal Digiplate:

 **WARNING**

Take the Thermal Digiplate out of the package and place it on a horizontal and stable table or desk.

 **WARNING**

As it weighs approximately 55 kg(121 lbs), it is dangerous for a single person to try to hold or carry the Thermal Digiplate. When taking it out of the package, take care not to injure your fingers or hands.

 **WARNING**

The Thermal Digiplate's center of gravity is at the front. Take care not to lose balance when carrying it. At least 2 persons are required to carry and install it.

 **WARNING**

Use extremely caution when carrying it on a slippery floor.

 **WARNING**

If it is dropped and damaged, turn off the power switch on the main body, disconnect the power cable from the electric outlet and contact the distributor. If it is used without servicing, it can cause a fire or electric shock.

 **WARNING**

Plug the power cable all the way into the electric outlet.

 **WARNING**

The thermal head is heated while the Thermal Digiplate is operating. This is not an abnormal phenomenon. It is heated to a high temperature. Never touch it.

 **WARNING**

If an abnormality occurs, take only the measures for the abnormalities described in this users manual. If normal operation cannot be recovered, contact the distributor from whom you bought it.

 **WARNING**

Use only the power cable supplied with the Thermal Digiplate. Be sure to connect the power cable to the electric outlet to be grounded according to all relevant local regulations (resistance: less than 100 ohm). If a short circuit occurs while the Thermal Digiplate is operating without being grounded, a fire or electric shock can occur. In addition, radio and television reception can be affected. If the Thermal Digiplate cannot be grounded, consult the distributor.

 **CAUTION**

Do not disconnect the power cable while data is being printed or transferred. Doing so can cause the Thermal Digiplate to break down.

**Note**

If you touch the surface of the thermal head directly with your hand, the head can be damaged. If hard particles, such as sand, enter the head, it can be damaged. Take care when handling the head.

**Note**

Use the USB cable supplied with the Thermal Digiplate to connect it to your computer when installing the Thermal Digiplate.

### 1.3 Kind of warning labels and its attachment part

The following warning labels are attached inside the Thermal DigiPlater to prevent the accident and avoid the danger. If the label come off or can't be seen, contact the distributor from whom you bought it immediately.

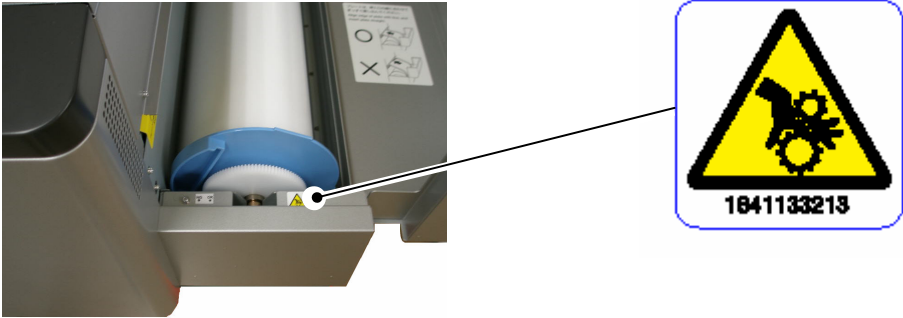
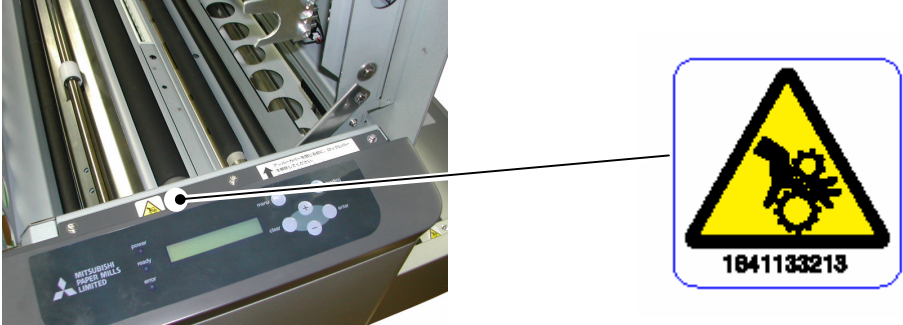
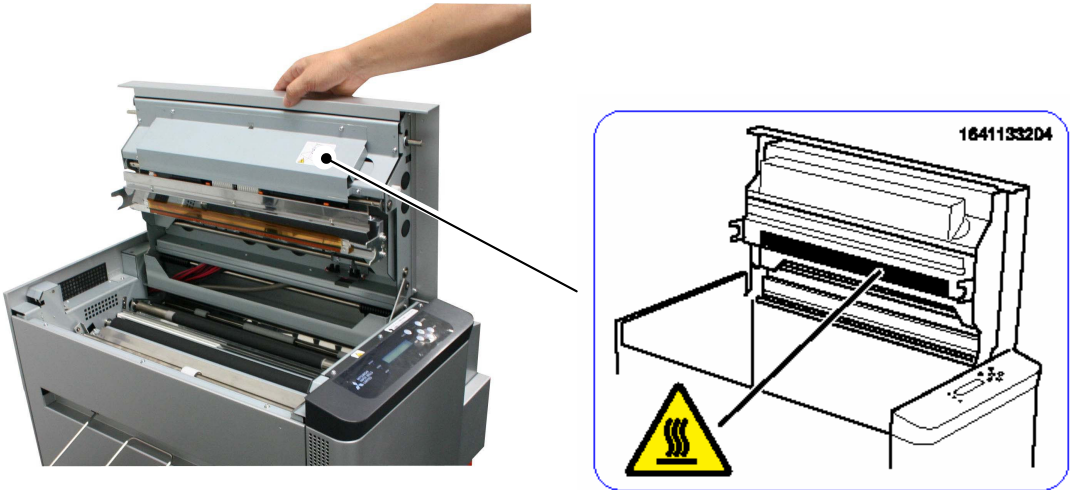

## 1.4 Handling plate before and after platemaking

When handling plate, observe the following instructions:

### Note

**When handling plate before platemaking:**

- ◆ Use plate specified by Mitsubishi Paper Mills, Ltd.
- ◆ Wrap the plate with the black polybag and avoid high temperature and high humidity, and store it in the cool and dark place.  
(at a temperature of 30°C(86 ° F) or lower and a humidity of 60% RH or less)
- ◆ Do not touch the plate surface with your hand.  
Finger prints can deteriorate the printing quality.

### Note

**When handling plate after platemaking:**

- ◆ Store plates avoiding direct sunlight.
- ◆ Store plates away from organic solvents such as benzine, thinner and alcohol. In addition, avoid direct contact with hands.  
If the printed images come into contact with hands or any of these substances, discoloration can occur to the plates.

# Chapter 2 Installation and Setup

## 2.1 Unpacking and setup procedure

This chapter explains procedures from unpacking to setting up the Thermal Digiplater. Be sure to read **Chapter 1 Safety Precautions** before proceeding to this chapter.

Perform the following to unpack and install:

- 1.** Open the box and take out the Thermal Digiplater and accessories.
- 2.** Check the names and functions of the Thermal Digiplater's parts.
- 3.** Take out the protective inserts.
- 4.** Connect the power cable.
- 5.** Connect the USB cable.
- 6.** Install the plate tray.
- 7.** Turn on the power switch.
- 8.** Set the spools to the plate and place the plate into the Thermal Digiplater.

## 2.2 Unpacking

First, unpack and check the contents.

The box contains the Thermal Digiplate, accessories and protective inserts. The accessories are: Spool, Flange, power cable, USB cable, plate tray, user's manual, the TDPController CD-ROM with the user's manual, Technical Guide, and Project warranty.

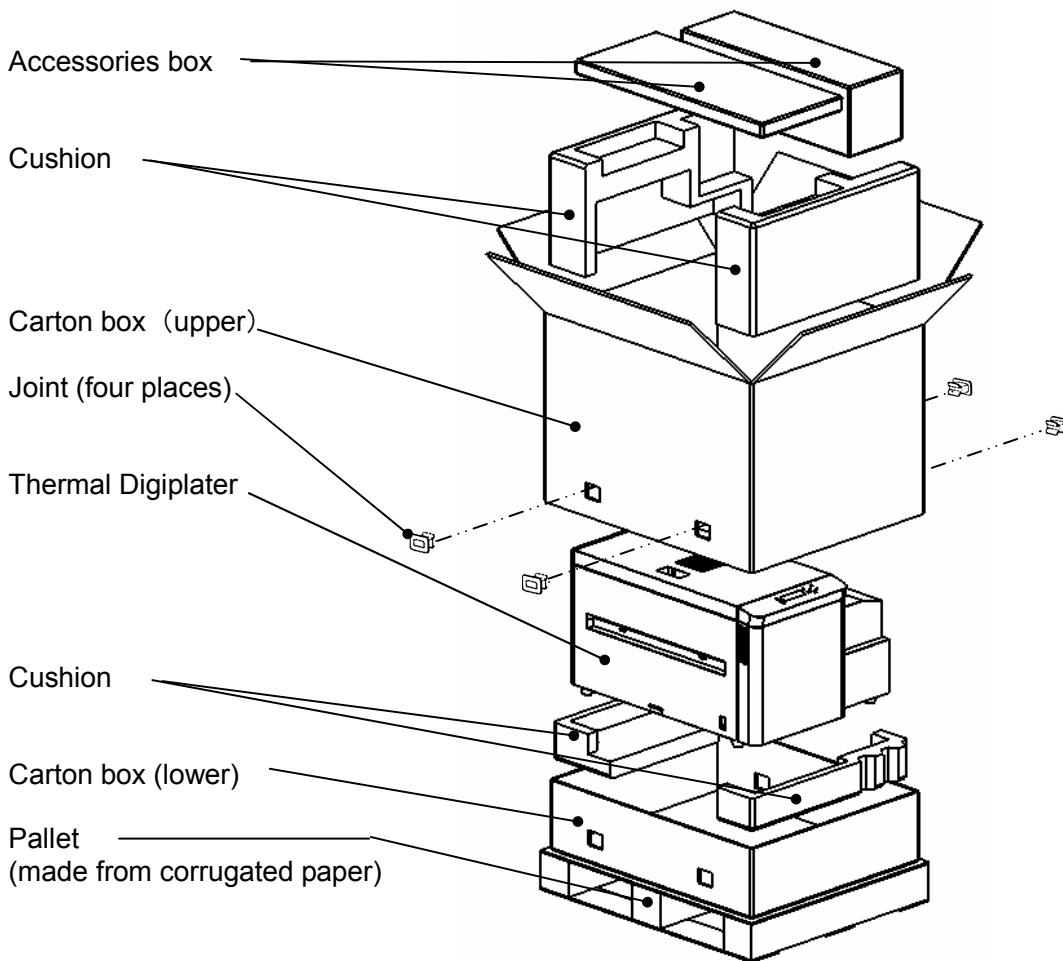

**⚠ CAUTION**

**This Thermal Digiplate weighs approx. 55 kg(121 lbs). Take care when handling it. When taking out and carrying, securely hold it by its bottom.**

**Note**

**Do not discard the packaging materials. The box and protective inserts will be required to transfer or transport the Thermal Digiplate. Keep them in a safe place.**

## 2.3 Checking the accessories

Take out the accessories from the box and from inside of the Thermal Digiplate. Check that the following items, as illustrated below, are present.

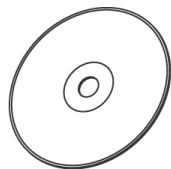
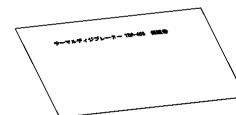
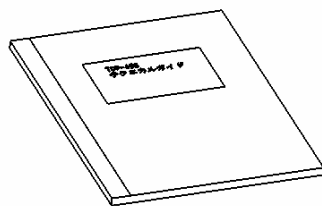
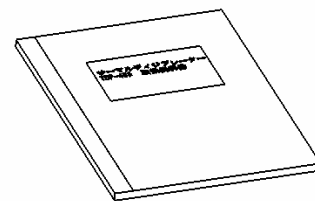
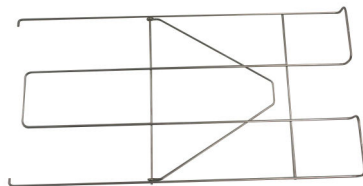
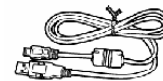
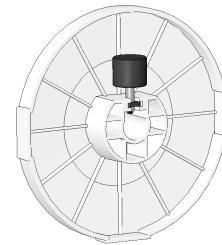
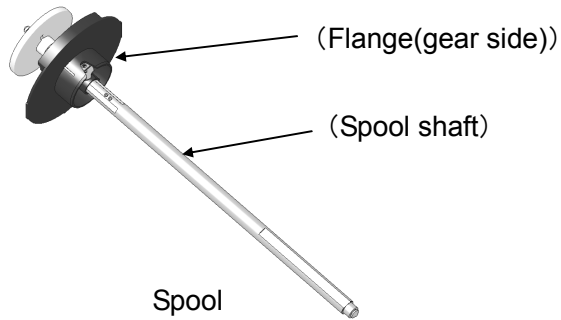

### Note

**If an accessory is missing, contact the distributor immediately.**

## 2.4 Names and functions of parts

### 2.4.1 Names of parts

#### ■ Front

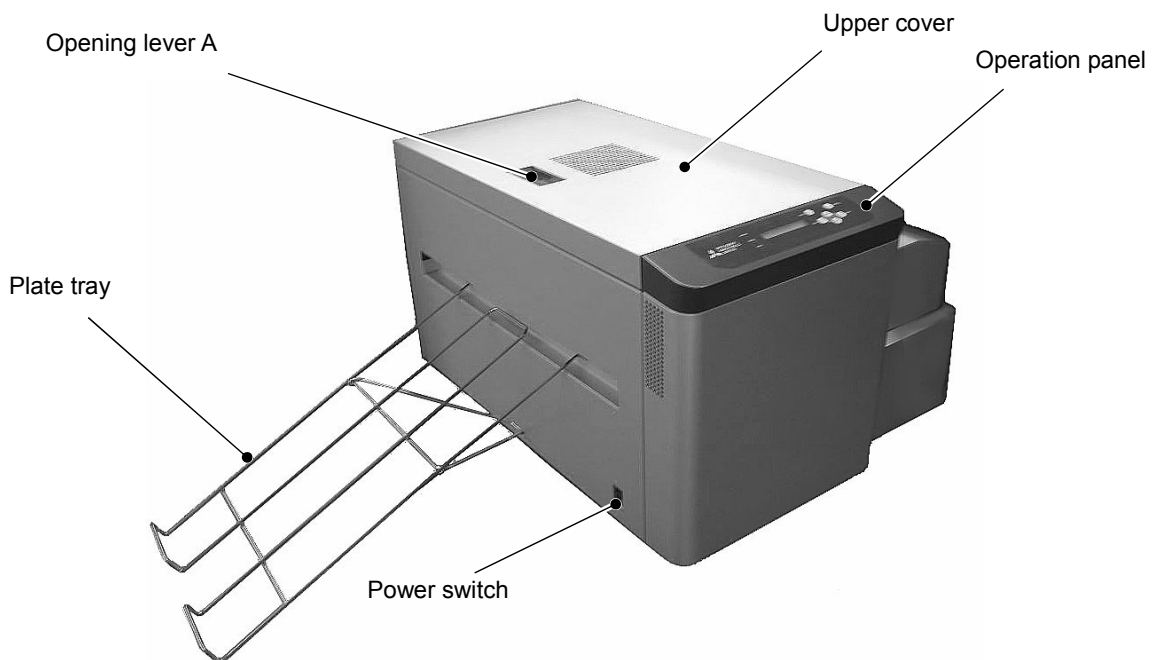

#### ■ Rear

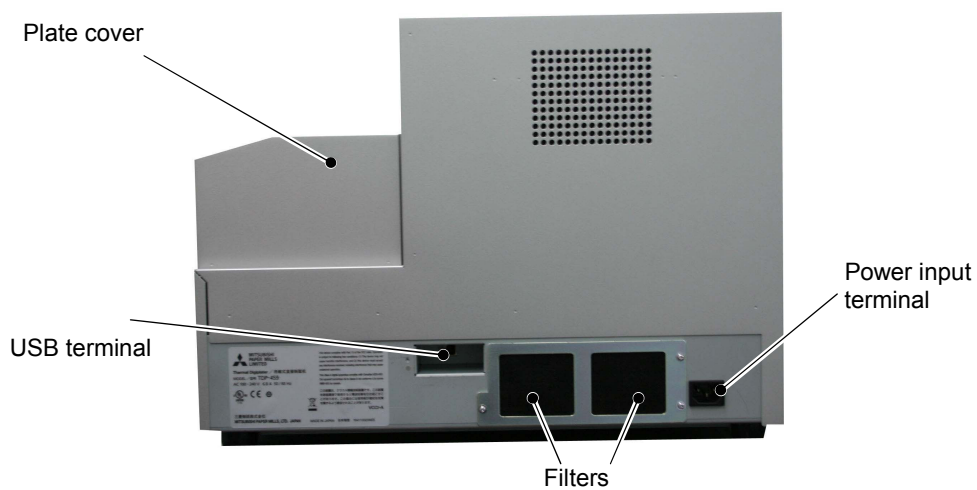



■ Inside the Thermal DigiPlater

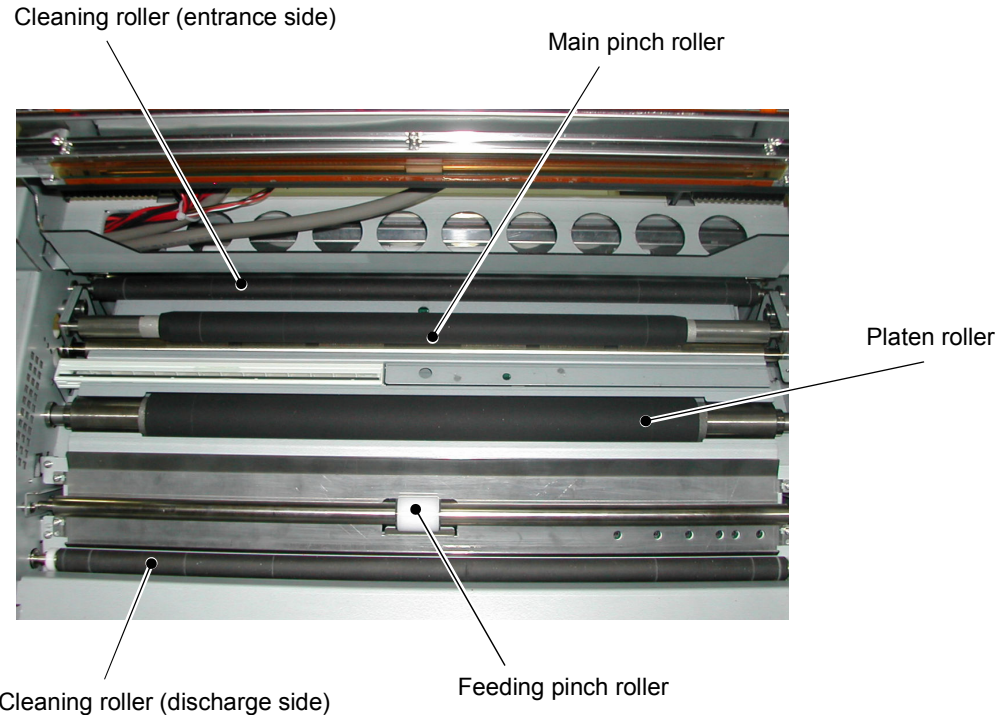

## 2.4.2 Functions of parts

Name	Function/Description
Upper cover	Open this cover when inspecting and cleaning the thermal head and the rollers such as the main pinch roller, the platen roller and so on, and when removing a jamming plate portion.
Operation panel	The operation buttons, LCD display (referred to as the LCD below) and status lamps are located here.
Power switch	Switch to turn the power to the Thermal Digiplate on or off. Pressing “   ” turns on the power while pressing “O” turns off the power. <b>&lt;Caution&gt; After turning off the power, turn on the power after a lapse of 3 seconds or more.</b>
Power input terminal	Connect the power cable.
USB terminal	Connect the USB cable.
Thermal head	Add the heat to the plate and print. <b>&lt;Caution&gt; The head is heated to a high temperature while the Thermal Digiplate is operating. Do not touch. Touching it directly with your hand can cause failure.</b>
Platen roller	Rubber roller to feed with plate.
Cleaning roller (Entrance and discharge sides)	Rubber rollers to remove dust and foreign matters from the plate surface. One installed at the entrance side and the other at the discharge side.
Filter	Prevent dust and foreign substances in air from entering inside the Thermal Digiplate.

## 2.5 Connecting the power cable

Connect the power cable by observing the following instructions:

1. Insert the power cable supplied into the power input terminal at the back of the Thermal Digiplater.

Power cable

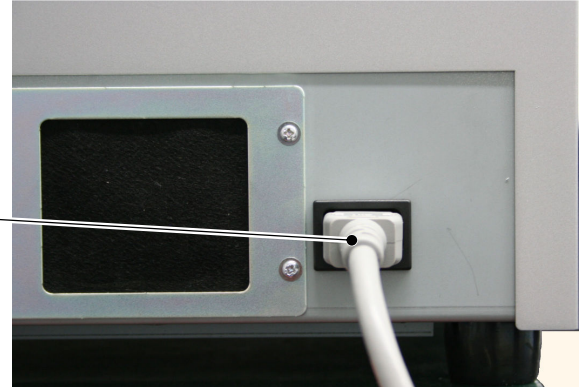

### **⚠ WARNING**

**Before connecting the power cable, make sure that the power switch is off.**

### **⚠ WARNING**

**Use only the power cable supplied with the product or a specified one. Be sure to connect the power cable to the electric outlet to be grounded according to all relevant local regulations (resistance: less than 100 ohm). If a short circuit occurs while the Thermal Digiplater is operating without being grounded, a fire or electric shock can occur. If the Thermal Digiplater cannot be grounded, consult the distributor.**

### **⚠ WARNING**

**Plug the power cable all the way into the electric outlet. Failure to do so can cause a fire or failure.**

### **⚠ WARNING**

**Do not connect or disconnect the power cable with wet hands. Doing so can cause an electric shock.**

### **⚠ WARNING**

**Do not scratch, damage or rework the power cable. Do not put a heavy article on the cable. Do not pull or forcibly bend it. Doing so can damage the power cable and cause a fire or electric shock.**

**⚠ WARNING**

When moving the Thermal Digiplate, disconnect the power cable from the electric outlet and make sure that all external connecting lines have been disconnected. If a cord is kept connected, it can be scratched, and a fire or electric shock can occur, or you can trip and be injured.

**⚠ WARNING**

If the Thermal Digiplate is not used for a long time, disconnect the power cable from the electric outlet for safety.

**⚠ WARNING**

Do not connect the power cable to an electric outlet to which other cords are connected. Requires a dedicated electric outlet. Doing so can cause a fire or electric shock.

## 2.6 Connecting the USB cable

1. Connect the USB cable connected to your PC to the USB terminal at the back of the Thermal Digiplate



Thermal Digiplate side is a type B connector(square)

USB cable  
[Product compatible with USB 2.0 standard]



**Note**

Use only the USB cable supplied with the product or a specified one. If a cable other than the supplied cable is used, incorrect printing can result.

**⚠ CAUTION**

Before disconnecting the USB cable, make sure that the Thermal Digiplate is in the standby state. If disconnected during data transfer, the Thermal Digiplate can be damaged.

## 2.7 Installing the plate tray

### WARNING

A plate cutter is installed inside the plate discharge port. Do not put fingers. Doing so can cause injury.

1. Insert one of the claws of the plate tray into the corresponding mounting hole for the plate tray.

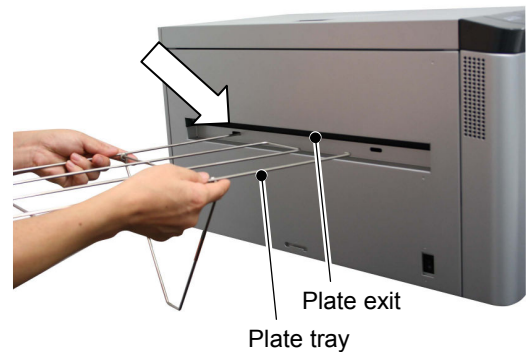

2. While slightly widening the plate tray, insert the other claw into the other mounting hole.

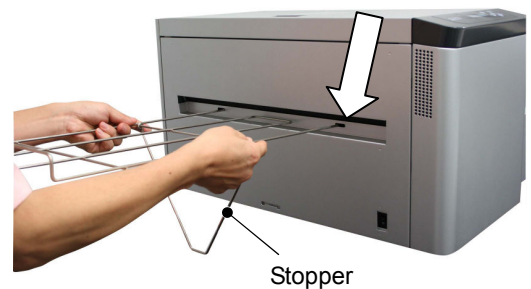

3. Secure the tray by inserting the bottom of the stopper into the stopper slit.

### CAUTION

Stacking quantity is up to 5 plates on the plate tray.  
Do not stack more than 5 plates on it.

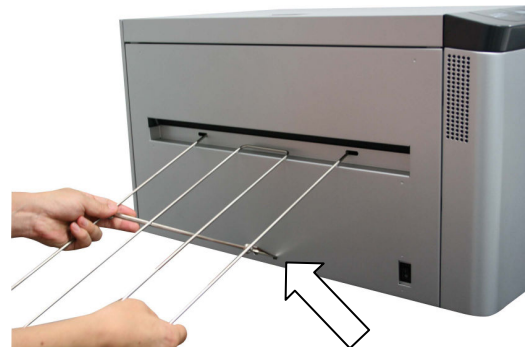

## 2.8 Setting the plate

1. Turn on the power to the Thermal Digiplate.



2. Set the size of the plate to be installed on the operation panel. See 3.3.1 **Selecting a plate size.**

3. By holding the opening lever B, open the plate cover.

Note
<b>Do not open the plate cover extremely quickly or forcibly 90 degrees or more.</b>

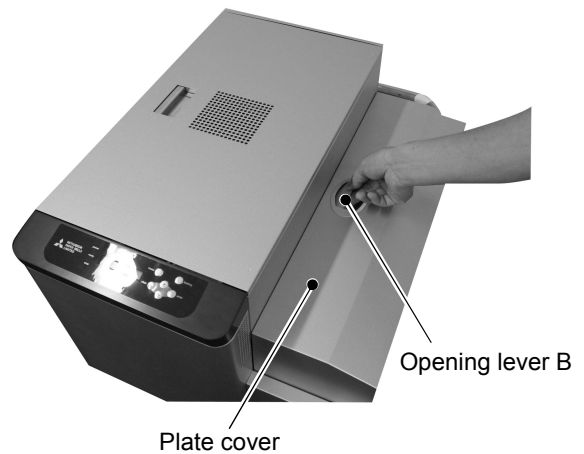

4. When there is any used plate, pull out the lead edge of the plate and lift up the plate with the spool, and take it out.

 CAUTION
<b>The plate weighs approx. 10 kg(22 lbs). Handle it carefully so as not to drop it. Dropping it is dangerous.</b>

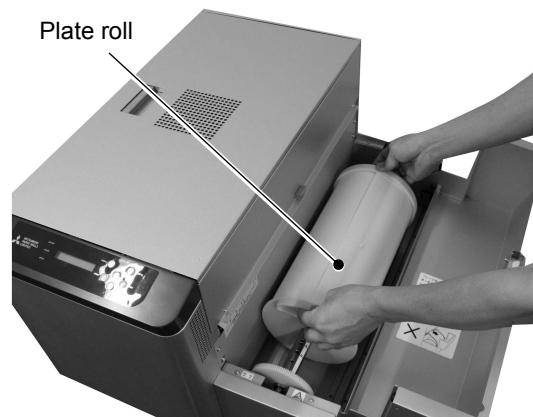

- 5.** Take out the new plate from the black polybag.

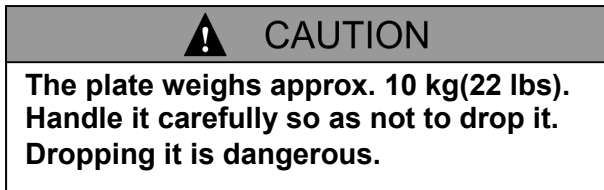

- 6.** Change the flange(gear side) position of the spool according to the size of the plate to be used.

Please refer to "2.9 The change method of flange position."

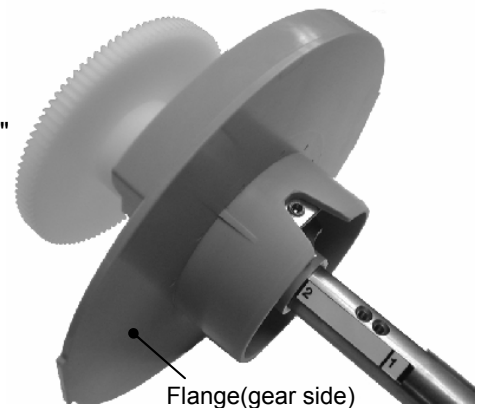

- 7.** Insert the shaft of the spool into the core of the plate and gently force the flange(gear side) of the spool on the side of the plate.

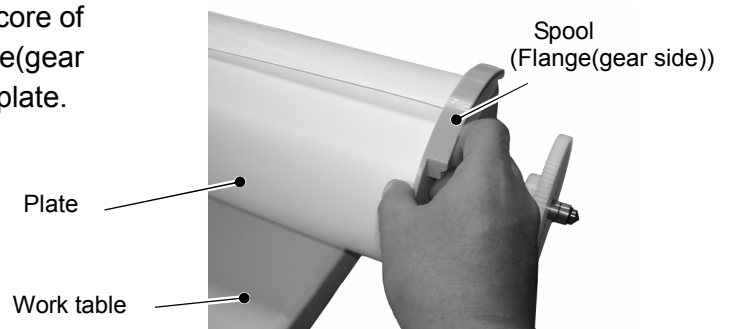

#### [Useful tip]

- When inserting the shaft of the spool into the core of the plate, place the plate so that the lead edge of the winding plate is upward. Then, insert the shaft of the spool from the right-hand side.

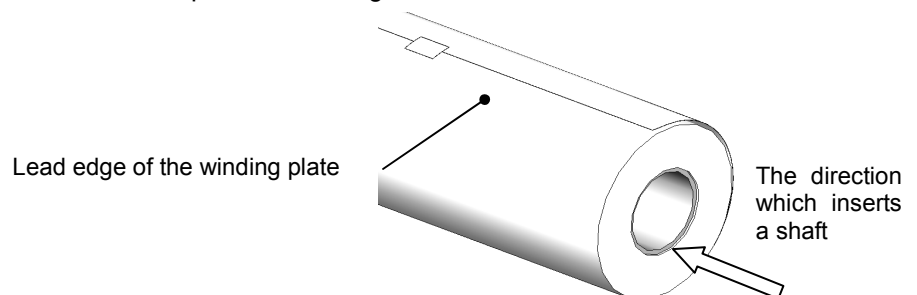

- As the outer diameter of the flange is larger than the outer diameter of the plate, it is recommended that this work is performed with the right-hand side of the plate protruding from the work table.

- 8.** Install and fit the flange(anti-gear side) to the end of the shaft on the opposite side of the plate.

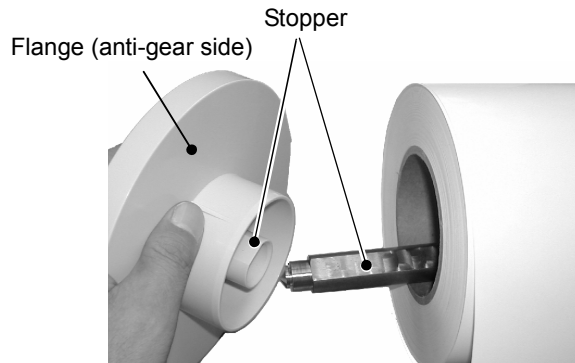

**[Useful tip]**

The flange (anti-gear side) has a stopper notch and the shaft has stopper notches to prevent empty rotation. Check the directions of the spool stopper notch and notches on the shaft to fit the spool correctly.

- 9.** Tighten the screw to fix, forcing the flange (anti-gear side) on the side of the plate, and fix the flange (anti-gear side).

**⚠ CAUTION**  
Do not tighten the screw too much. It may damage flange.



- 10.** Install the plate by placing the spool into the plate box.

**⚠ CAUTION**  
The plate weighs approx. 10 kg(22 lbs). Handle it carefully so as not to drop it. Dropping it is dangerous.





- 11.** Remove the seal fixing the end of the plate.

Fixing seal

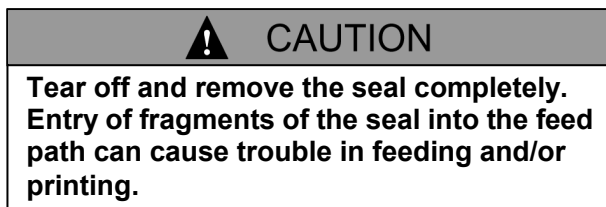

- 12.** Feed in the plate by hand, aligning the side edge of the plate with the line on the plate guiding seal.

Plate guiding seal



LED

#### [Useful tip]

- When the end of the plate is inserted into the plate feeding port, the motor starts to operate to assist the feeding of the plate. The motor will stop when the plate setting is completed.
- When the plate setting is completed, the "NG" LED lamp goes off and "OK" LED lamp turns on.

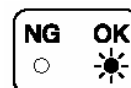

**13.** Slowly close the plate cover.

 <b>CAUTION</b>
<b>Be careful not to catch fingers when closing the plate cover.</b>



**14.** Press the **loading** button on the operation panel.

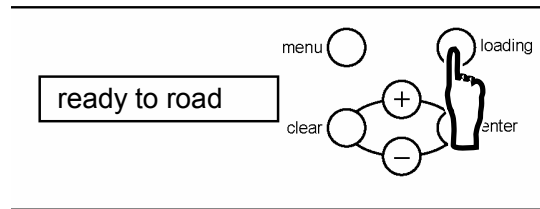

**[Useful tip]**

If the size of the plate placed in this machine does not match the plate size set, the loading will not be completed correctly. If an error occurs, check the size of the actual plate and the plate size set on this machine. Then, install and set the correct plate.

**15.** Plate moves back and forth, and set the skew right. Then cut 2 plates with about 310mm(12.2inches) and discharge them forcibly.

- When loading button is pressed for more than 2 seconds, the plate is not cut off. Please refer to “3.2.2 Operation button”.

## 2.9 Change Method of Flange Position

Please change the flange position of a spool according to the size of the plate to be used.

### 1. Loosen the screw which secures the flange.

Turns in the direction of the illustration arrow, applying a finger to the knob part of the fixed screw.

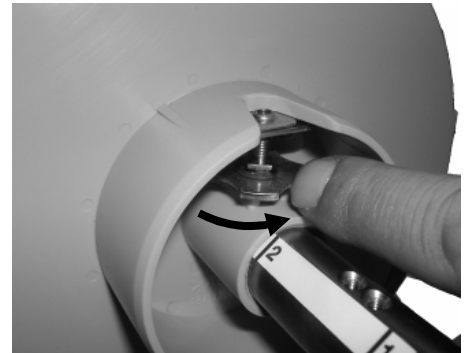

### 2. Flange is set at the position corresponding to plate size.

- Please confirm the relation between plate size and a flange position using table on the right.
- Please unite the field of a flange inner side with the line described at the spool shaft.

Flange position	Plate width(inch)
1	324(12.75) 318(12.50)
no number	310(12.19) 305(12.00)
A	292(11.5) 286(11.25) 279(11.00)

- On spool shaft, there are indications of 2 to 5 and B, however these are not used in this product (TDP-324)

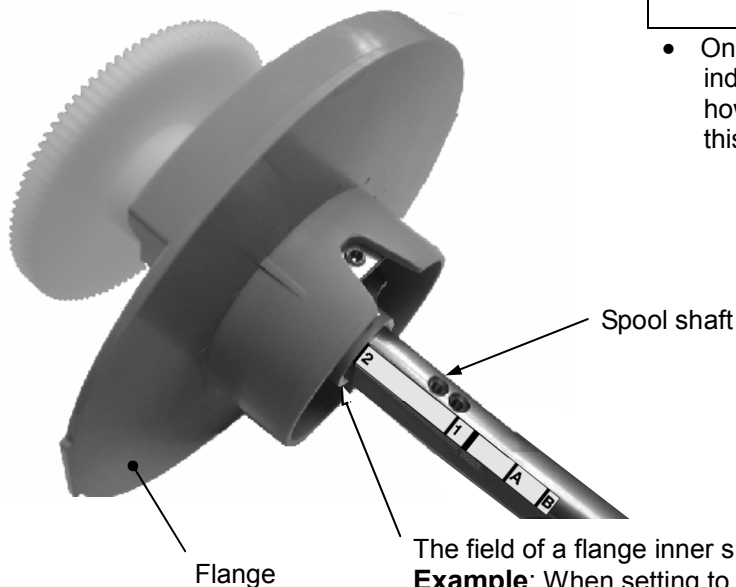

The field of a flange inner side meets with a line.

**Example:** When setting to flange position "2" The line on the left-hand side of number "2" and the field of a flange inner side should line up.

### 3. Tighten the screw and fix flange.

- Turns in the direction of the illustration arrow, applying a finger to the knob part of a fixed screw.
- Please fasten securely, turning until the screw stops.



(Flange set position and the relation of the range which can be printed)

Relation between flange set position and print area is shown on diagram below.  
Please confirm the print area before generating print data.

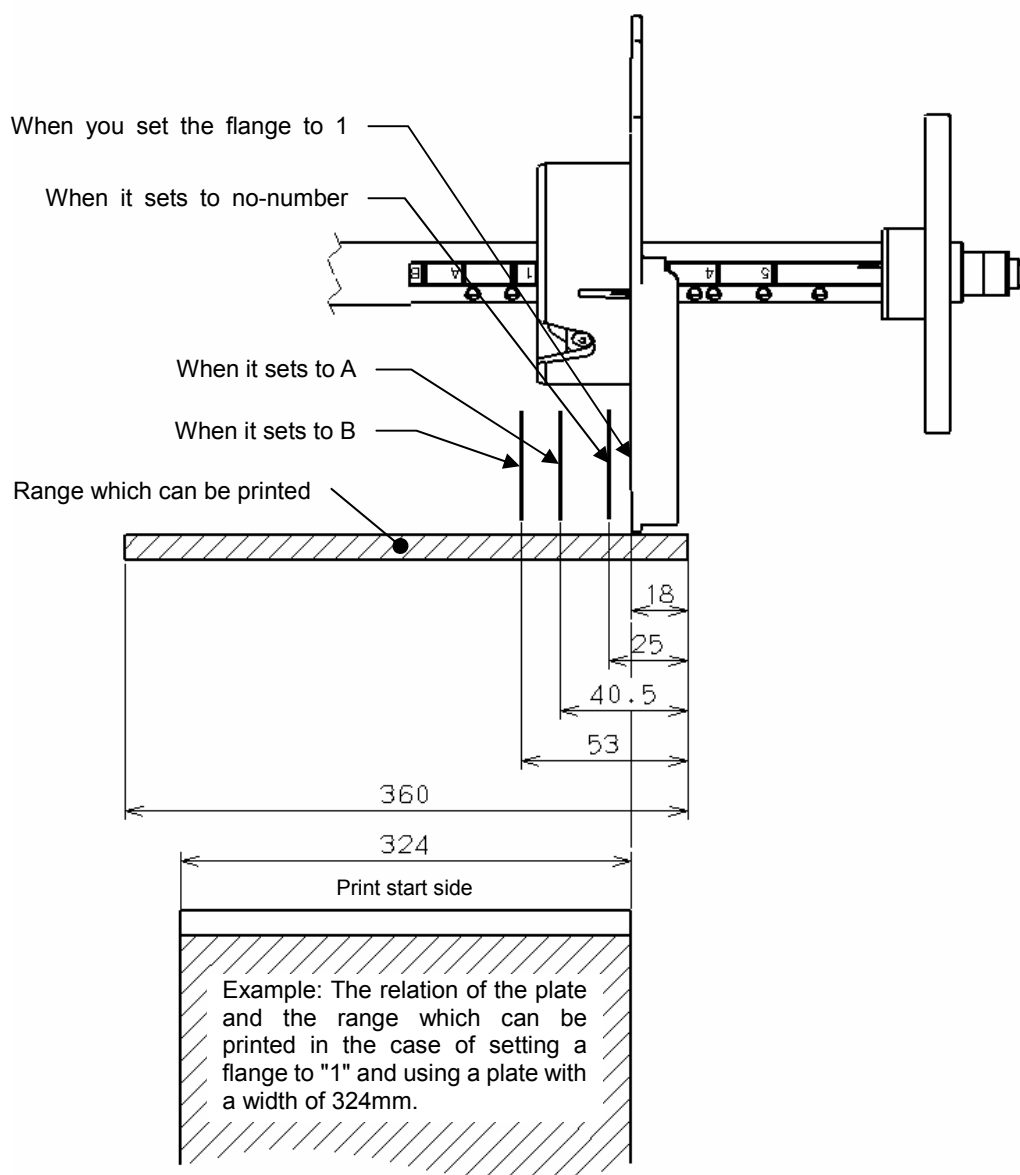

# Chapter 3 Use of Operation Panel

## 3.1 Power switch

The power switch is located on the left side surface of this machine. Pressing the upper side ("I") turns on the power while pressing the lower side ("O") turns off the power.



### CAUTION

**Before disconnecting the USB cable, make sure that the Thermal Digiplate<sup>®</sup> is in the standby state. If disconnected during data transfer, incorrect printing can result.**

## 3.2 Operation panel

The buttons, LED lamps and LCD on the operation panel are explained below.

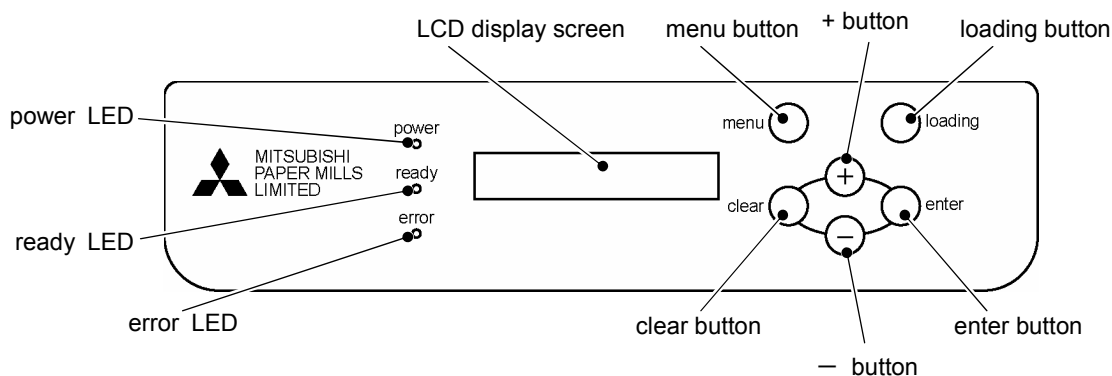

### 3.2.1 LED indications

LED indications are shown in the following table.

Name	Indicated color	Description
power LED	Orange	This lamp is on when the power is on.
ready LED	Green	This lamp is on when the Thermal Digiplate is ready for printing.
error LED	Red	This lamp is on when an abnormality occurs in the Thermal Digiplate. Also, this is on during "initializing" and "booting up".

### 3.2.2 Operation button

The functions of the operation buttons are shown in the following table.

Name	Function
loading button	Use this button to set a plate. 1. When this button is pressed at Ready state, the plate is fed for a certain length of plate and cut off, then it is set at the set position. 2. When this button is pressed for more than 2 seconds at Ready state, the plate is fed for a certain length of plate, and set at the set position.
menu button	Use this button to select from the menu.
enter button	Use this button to save an operation or a setting to be executed in the user mode.
clear button	Use this button to exit the currently selected menu item in the user mode.
+ button	Use this button to select an item from the menu in the user mode.
- button	Use this button to select an item from the menu in the user mode.

### 3.2.3 LCD indications

The LCD shows the Thermal Digiplate status as shown in the following table.

\*: The following chart is the list of display in Millimeter Mode (factory setting). In case of Inch Mode (factory setting), some display may differ. Please refer to the next page for details.

Data shown on the LCD		Description
English	Japanese	
Initializing	シヨキカチュウ	The Thermal Digiplate is being initialized.
Booting up	キドウチュウ	The firmware is being started.
In the case of the plate remaining switch on		The Thermal Digiplate is ready for printing.
□□□ □□□×□□□ □□m *1 *2 *3	□□□ □□□×□□□ □□m *1 *2 *3	*1. Selected plate size channel number is displayed. eg. Custom channel: C01 Free mode channel: F01 *2. Set plate name (size) is displayed. *3. The remaining length(m) of the plate set in the Thermal Digiplate is displayed.
In the case of the plate remaining switch off		The Thermal Digiplate is ready for printing.
□□□ □□□×□□□ *1 *2	□□□ □□□×□□□ *1 *2	*1. Selected plate size channel number is displayed. eg. Custom channel: C01 Free mode channel: F01 *2. Set plate name (size) is displayed.
Ready to load	ロード インク シテタ サイ	The Thermal Digiplate is ready for plate loading as the plate has been set.
Receiving	データ ジュシチュウ	Data is being received.
Printing	プリント チュウ	The Thermal Digiplate is in printing operation.
Cooling Down	ヘッド レイヤチュウ	The thermal head is being cooled. Printing is temporarily suspended until the thermal head has cooled down.
Warming Up	ヘッド カオンチュウ	The thermal head is being preheated. Printing is temporarily suspended until the thermal head has warmed up.
Plate Loading	プレート ロード チュウ	Plate is being loaded.
Plate Reloading	プレート サイロード チュウ	The end of the plate is being fed to the standby position.
Data Creating	データ テンカイチュウ	Test print data is being generated.

\*: In case of Inch Mode (factory setting), print status is shown as follows.

Data shown on the LCD		Description
English	Japanese	
In the case of the plate remaining switch on		The Thermal Digiplate is ready for printing.
□□□ □□.□×□□.□ □□□ *1 *2 *3	□□□ □□.□×□□.□ □□□ *1 *2 *3	*1. Selected plate size channel number is displayed. eg. Custom channel: C01 Free mode channel: F01 *2. Set plate name (size) is displayed. *3. The remaining length of the plate set in the Thermal Digiplate is displayed in feet. (unit is omitted)
In the case of the plate remaining switch off		The Thermal Digiplate is ready for printing.
□□□ □□.□×□□.□ *1 *2	□□□ □□.□×□□.□ *1 *2	*1. Selected plate size channel number is displayed. eg. Custom channel: C01 Free mode channel: F01 *4. Set plate name (size) is displayed.

### 3.3 Explanation of the user mode

In the user mode, the following are possible:

Items available in the user mode

LCD indications		Description
English	Japanese	
Plate Size	プレート サイズ	Select a plate size channel.
Size Set	サイズ セッテイ	Set a plate size.
Density	Density	Adjust the density of print.(-20% to +40% in increments of 1%)
Firmware Version	Firmware Version	The firmware version can be checked.
Head Cleaning	ヘッド クリーニング	Execute thermal head cleaning. Set thermal cleaning mode.
Plate	プレート	Display plate remains, and resets plate remains counter.
Counter	カウンタ	Display print count, and resets print counter.
Remains Sw	ザンリョウ スイッチ	Set on or off for display of plate remains.
Platen Cleaning	プレートン クリーニング	Execute platen cleaning.
Pinch Cleaning	ピンチ クリーニング	Execute pinch cleaning and sets cleaning mode.
Manage Count	マネージ カウント	Display accumulated print distance. This message is displayed only when Manage Count Sw is set at ON (factory setting).
Interval Set	インターバル セッテイ	Set a plate number that you want to stop printing (Thermal head maintenance purpose)

1. To switch to the user mode, press the **menu** button in the ready state.

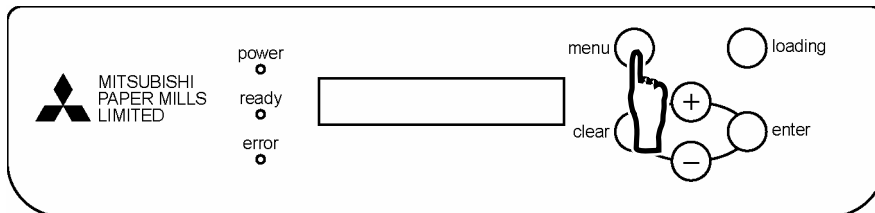

2. Pressing the + or - button repeatedly changes the menu item available.

The message shown on the LCD will change as show in below.

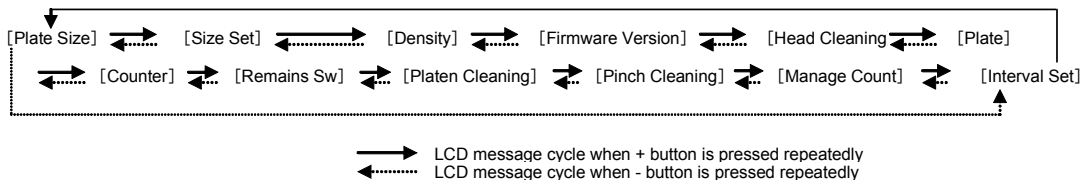



### 3.3.1 Selecting a plate size channel

1. In the ready state, press the **menu** button and display "Plate Size" on the LCD.

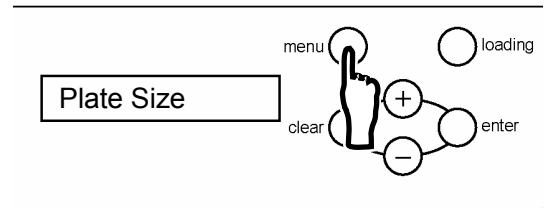

2. Press the **enter** button to select the operation for changing the plate size channel.

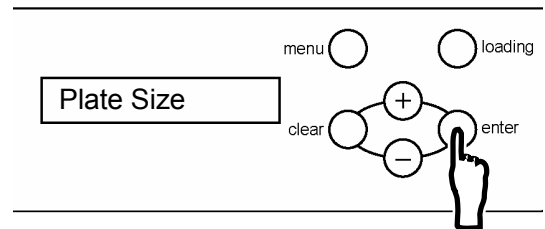

3. Press the **+** or **-** button to display a different plate size channel.

- In case of Inch Mode, it will be shown in inches, as shown below.

[Size01:12.7×19.3]

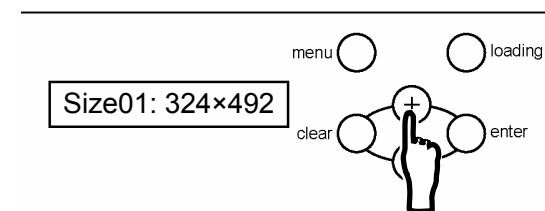

4. Press the **enter** button to select the desired plate size channel.

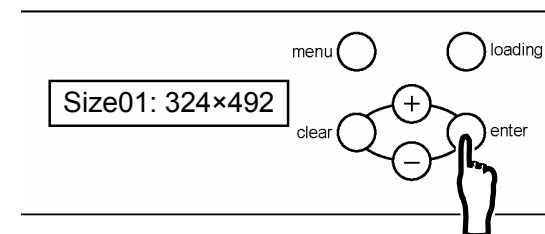

5. Press the **clear** button repeatedly until the ready state is displayed.

### 3.3.2 Setting the plate size

**1.** In the ready state, press the **menu** button once, press the **+** button once, and display “Size Set” on the LCD.

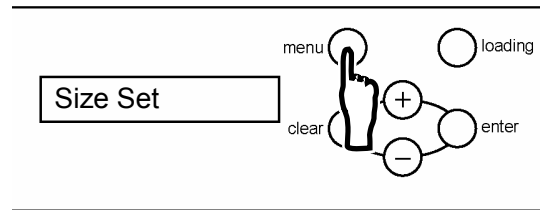

**2.** Press the **enter** button to select the operation for selecting a plate size channel.

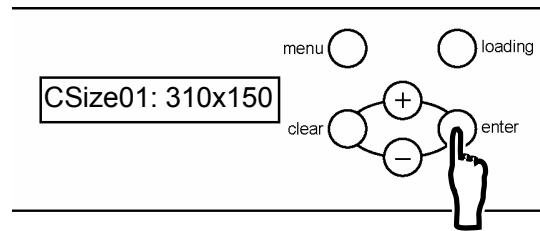

**3.** Press the **+** or **-** button to display a different plate size channel.

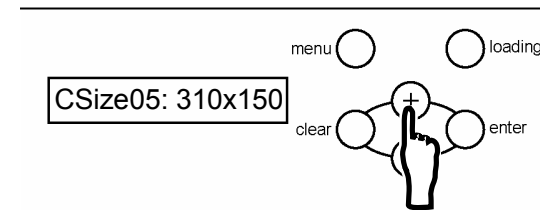

**4.** Press the **enter** button to select the desired plate size.

- CSize xx: Custom size channels (10)
- FSize xx: Free-mode channel (5)

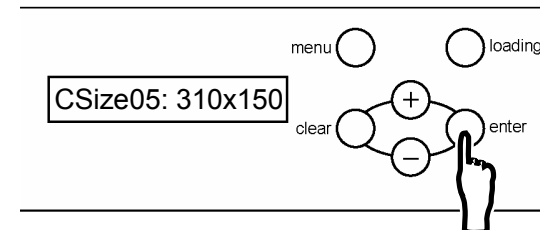

**5.** Press the **enter** button to select the plate width.

- In case of Millimeter Mode, it can be selected from 8 types as shown below.  
254\*,279,286,292,305,310,318,324(mm)
- In case of Inch Mode, it can be selected from 8 types as shown below.  
10.00\*,11.00,11.25,11.5,12.00,12.19,12.50,12.75(inch)

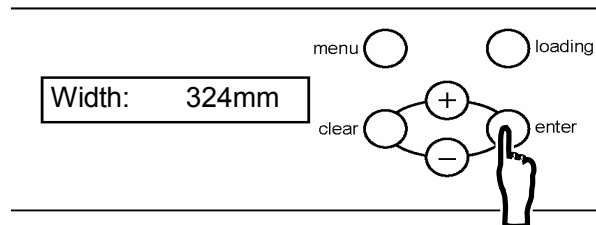

- The size, 254mm(10.00 inch), isn't available on TDP-324 though you choose it.
- The size, 254mm(10.00) is only available at the specific model, **TDP-324B**.

- 6.** If you set a plate size for a **free-mode channel**, this set up is finished. Press the **clear** button repeatedly until the ready state is displayed.

If you set a plate size for a **custom mode channel**, please move to “step 7”.

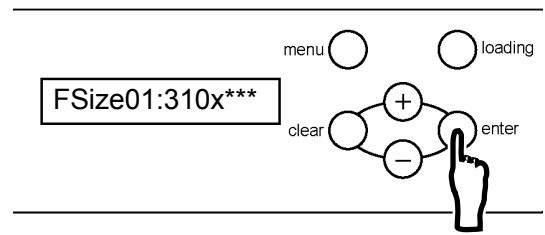

- 7.** Press the **enter** button to confirm the width setting. Then, set a plate length.

- In case of Millimeter Mode  
It can be set from 150mm to 530mm in increments of 1mm.
- In case of Inch Mode  
It can be set from 5.91 inches to 20.87 inches, In increments of 1/100 inch.

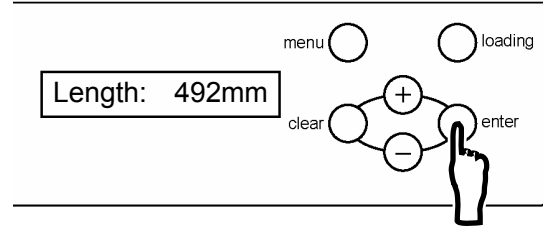

#### [Useful tip]

To change values, use the following buttons:

- In case of Millimeter Mode
  - menu** button: Increment the number by 10
  - +** button: Increment the number by 1
  - loading** button: Decrement the number by 10
  - button: Decrement the number by 1
- In case of Inch Mode
  - menu** button: 2-digit integral part is incremented by 10.
  - loading** button: 2-digit integral part is decremented by 10.
  - +** button: 2-digit decimal number area is incremented by 1.
  - button: 2-digit decimal part decremented by 1.

- 8.** Press the **enter** button to confirm the length setting.

- 9.** Press the **clear** button repeatedly until the ready state is displayed.

### 3.3.3 Adjusting the print density

1. In the ready state, press the **menu** button once, press the **+** button until “Density” displays on the LCD.

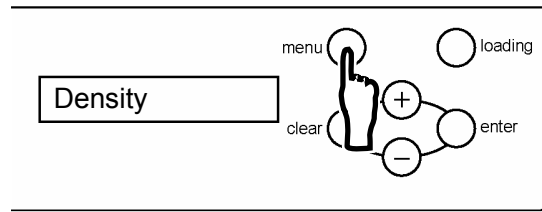

2. Press the **enter** button to select the operation for adjusting the print density.

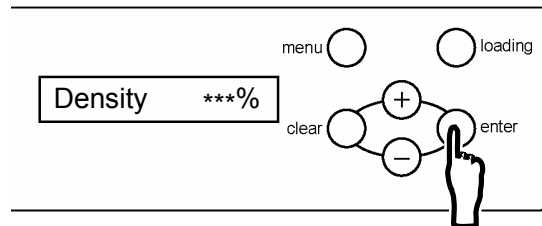

3. Change the print density by pressing the **+** or **-** button.

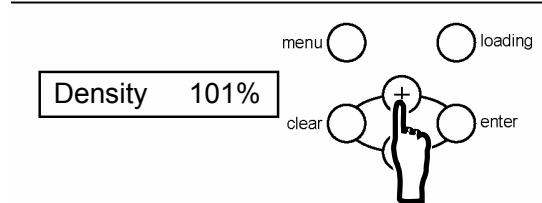

**[Useful tip]**

The density can be adjusted within -20% to +40%, in increments of 1%.

4. Press the **enter** button to confirm the changed density.

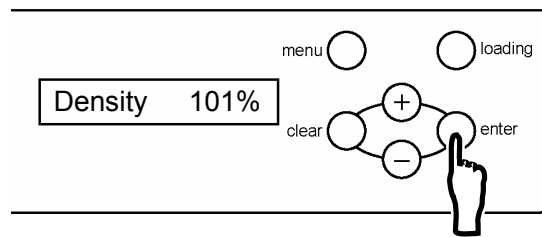

5. Press the **clear** button repeatedly until the ready state is displayed.

### 3.3.4 Checking the firmware versions

1. In the ready state, press the **menu** button once, press the **+** button until “Firmware Version” displays on the LCD.

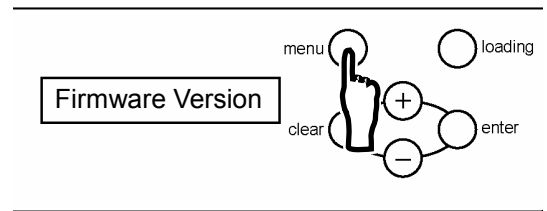

2. Press the **enter** button to select the operation for checking firmware versions.

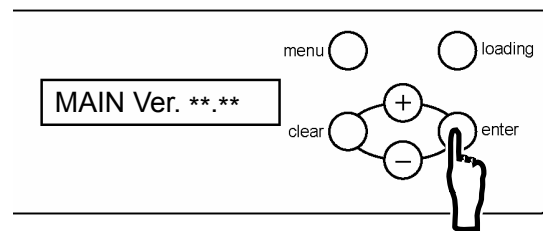

3. Press the **+** or **-** button to display another firmware version.

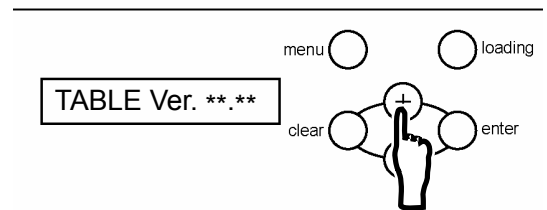

4. Press the **clear** button repeatedly until the ready state is displayed.

### 3.3.5 Setting the Head Cleaning Mode and Execution of Head Cleaning

#### ■ Setup of the automatic cleaning mode(ON/OFF)

The automatic cleaning mode(ON/OFF) is set as follows.

When it is set at ON, the automatic head cleaning is executed every time before printing.

1. In the ready state, press the **menu** button once, press the **+** button until display "Head Cleaning" on the LCD.

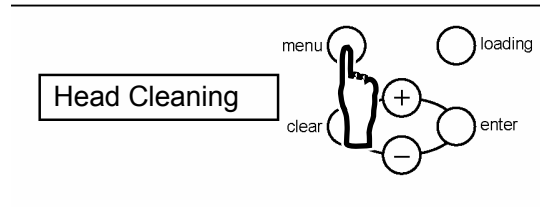

2. Press the **enter** button to select the operation for setting the Cleaning mode.

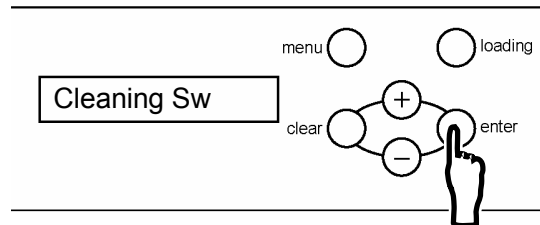

3. Press the **enter** button, and display the setting state (on/off) of head cleaning mode.

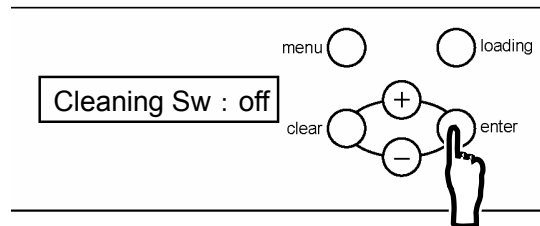

4. Press the **+** or **-** button to change the setting (on/off) of head cleaning mode.

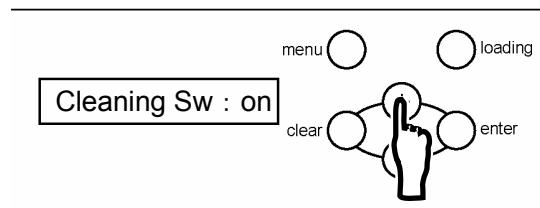

5. Press the **enter** button to confirm the setting (normal/Special) of head cleaning mode.

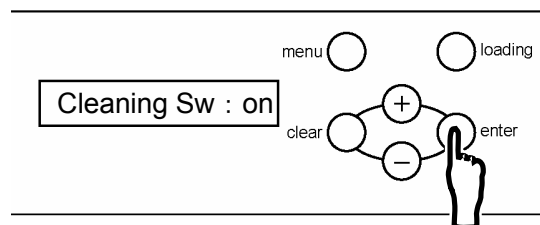

6. Press the **clear** button repeatedly until the ready state is displayed.

## ■ Setup of the head cleaning mode (Normal/Special)

Select a head cleaning mode (normal mode / special mode)

- Normal Mode: Black bar with setup length is printed.
- Special Mode: Black bar is printed in the blank area at the top of the printed plate.

1. In the ready state, press the **menu** button once, press the **+** button until "Head Cleaning" displays on the LCD.

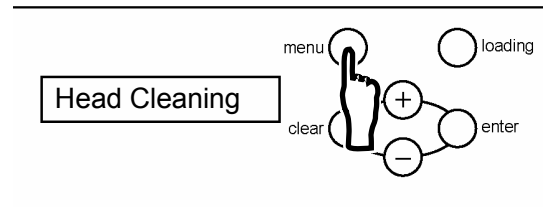

2. Press the **enter** button once, press the **+** button until "Cleaning mode" displays on the LCD.

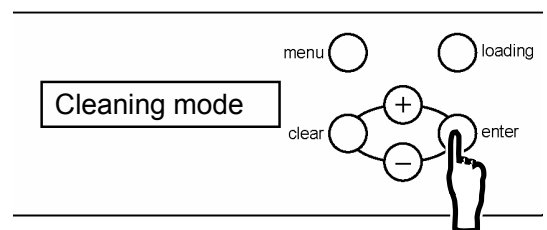

3. Press the **enter** button, and display the setting state (Normal/Special) of head cleaning mode.

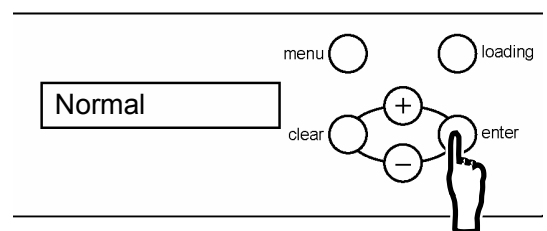

4. Press the **+** or **-** button to change the setting (Normal/Special) of head cleaning mode.

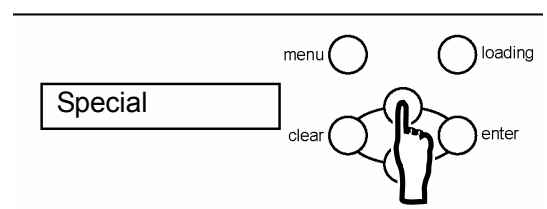

5. Press the **enter** button to select the operation for setting the state (Normal/Special) of head cleaning mode.

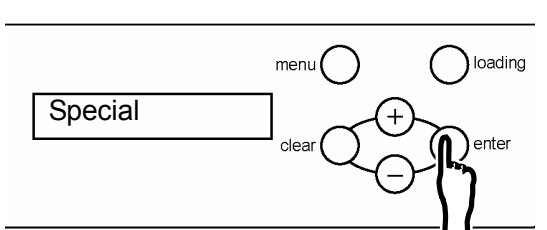

6. Press the **clear** button repeatedly until the ready state is displayed.

**■ Setup of the cleaning length (Normal mode)**

The length of the black bar printed at the time of head cleaning(Normal mode) execution is changed as follows.

- 1.** In the ready state, press the **menu** button once, press the **+** button until "Head Cleaning" displays on the LCD.

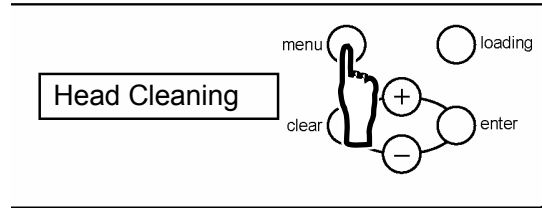

- 2.** Press the **enter** button once, press the **+** button once, and display "Cleaning Length" on the LCD.

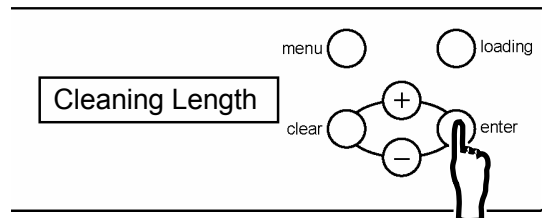

- 3.** Press the **enter** button, and display the setting state of cleaning length.

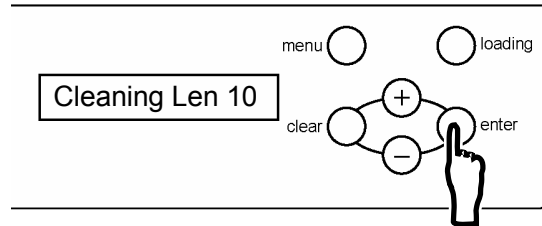

- 4.** Press the **+** or **-** button to change the setting of the cleaning length.

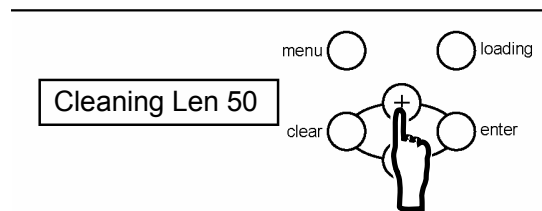

**【Useful tip】**

It can be set from 10mm to 50mm, **in increments of 1mm**.  
When the setting value is enlarged, the effect of head cleaning becomes large, but cleaning time becomes long.

- 5.** Press the **enter** button to confirm the setting of the special length.

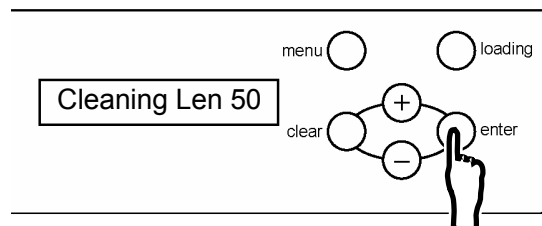

- 6.** Press the **clear** button repeatedly until the ready state is displayed.



### ■ Setup of the cleaning length (Special mode)

The length of the black bar printed at the time of head cleaning(Special mode) execution is changed as follows.

1. In the ready state, press the **menu** button once, press the **+** button until "Head Cleaning" displays on the LCD.

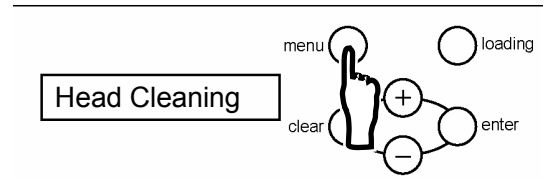

2. Press the **enter** button once, press the **+** button until "Special Length" displays on the LCD.

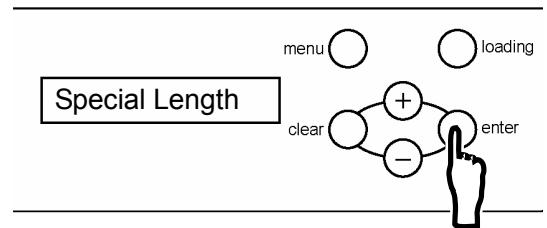

3. Press the **enter** button, and display the setting state of special length.

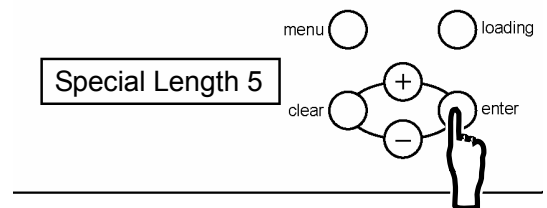

4. Press the **+** or **-** button to change the setting of the special length.

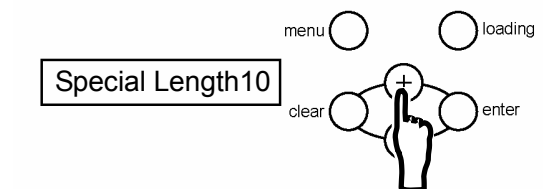

#### 【Useful tip】

It can be set from 5mm to 10mm, **it increments of 1mm.**

When the setting value is enlarged, the effect of head cleaning becomes large, but cleaning time becomes long.

5. Press the **enter** button to confirm the setting of the special length.

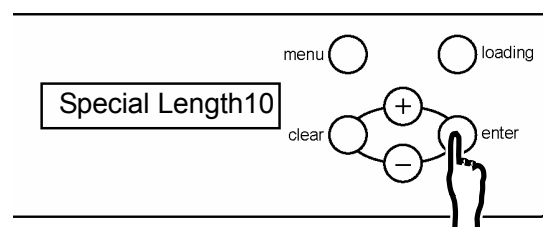

6. Press the **clear** button repeatedly until the ready state is displayed.

■ **Setup of head cleaning interval**  
Set the interval for head cleaning.

**1.** In the ready state, press the **menu** button once, press the **+** button until "Head Cleaning" displays on the LCD.

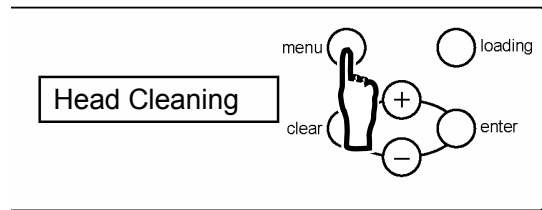

**2.** Press the **enter** button once, press the **+** button until "Cleaning Num" displays on the LCD.

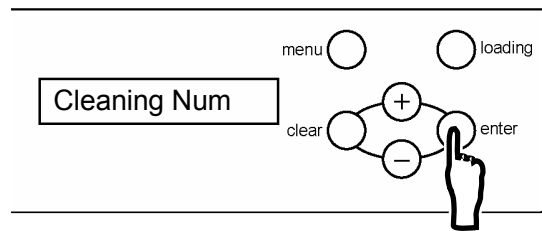

**3.** Press the **enter** button, and display the setting state of cleaning interval.

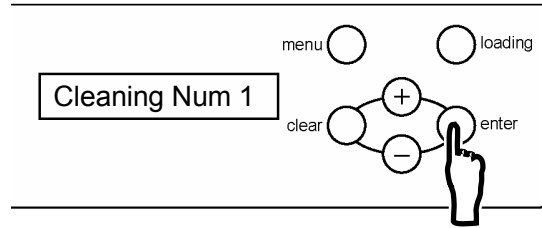

**4.** Press the **+** or **-** button to change the setting of cleaning interval.

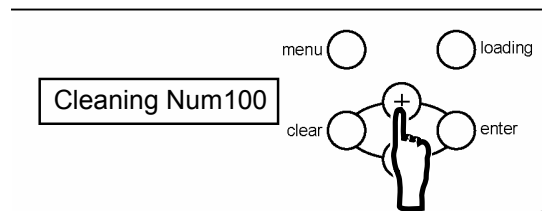

**[Useful tip]**

It can be set from 1 to 100 in increments of 1.  
When "1" is selected, the head cleaning is executed every time. When "100" is selected, the head cleaning is executed every 100 prints.

**5.** Press the **enter** button to confirm the setting of cleaning interval.

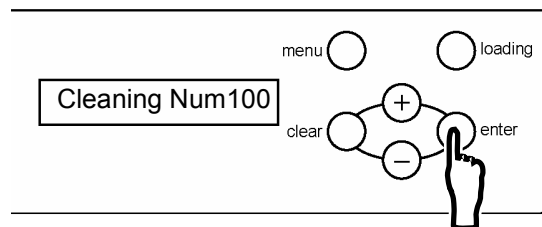

**6.** Press the **clear** button repeatedly until the ready state is displayed.

**■ Execution of head cleaning**

Head cleaning is executed. (Black bar with setup length is printed and discharged) as follows.

\* Cleaning length at Normal Mode is applied.

- 1.** In the ready state, press the **menu** button once, press the **+** button until "Head Cleaning" displays on the LCD.

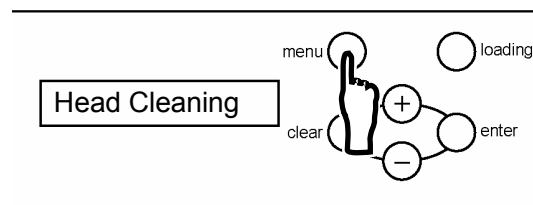

- 2.** Press the **enter** button once, press the **+** button until "Cleaning" displays on the LCD.

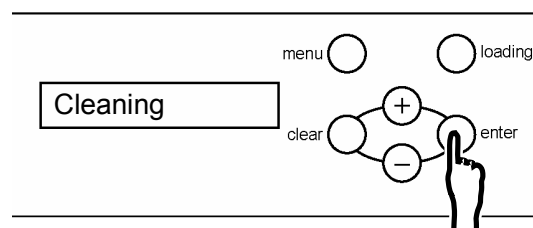

- 3.** Press the **enter** button to execute head cleaning.

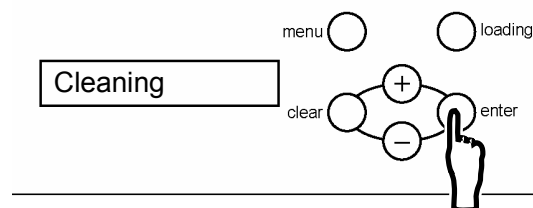

- 4.** Press the **clear** button repeatedly until the ready state is displayed.

### 3.3.6 Display of Plate Remains, and Reset of Plate Remains Counter

Display of plate remains and reset of plate remains counter are executed as follows.  
 When reset is executed, plate remains counter is 75m or 246ft at the time of brand-new plate, and printed length is subtracted in increments of 1m or 1ft until reset is executed next time.

1. In the ready state, press the **menu** button once, press the **+** button until "Plate" displays on the LCD.

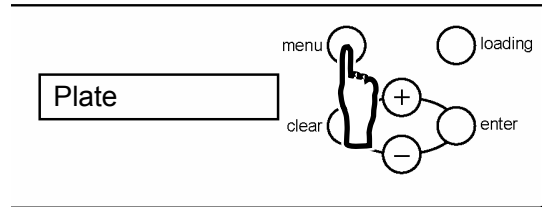

2. Press the **enter** button, and display the remains of the plate.

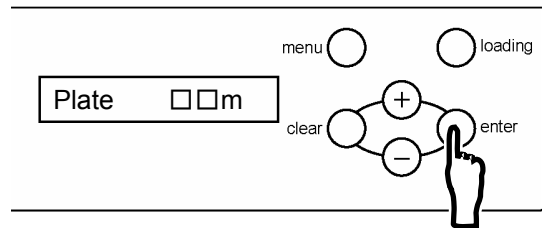

3. Press the **enter** button to come to the state which can reset the remains of the plate.

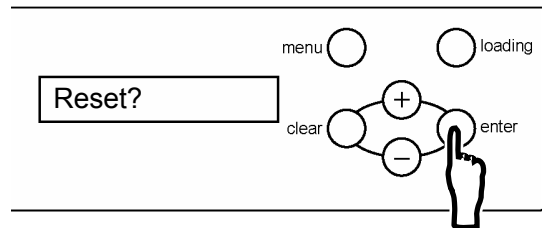

4. Press the **enter** button to reset the remains of the plate.

※. Press the **clear** button when not resetting.  
 • In case of Feet Mode, it will be shown in feets, as shown, [Plate 246 ft]

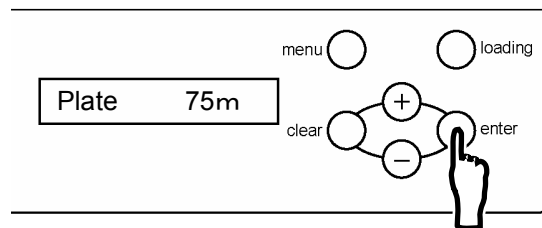

5. Press the **clear** button repeatedly until the ready state is displayed.

### 3.3.7 Display of Print Counter, and Reset of Print Counter

Display of print counter and reset of print counter are executed as follows.

Where reset is executed, print counter is 「0」, and the number of the printed plates is added until reset is executed next time.

1. In the ready state, press the **menu** button once, press the **+** button until "Counter" displays on the LCD.

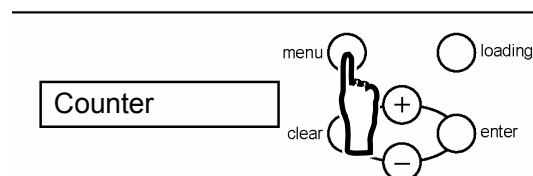

2. Press the **enter** button, and display the print counter.

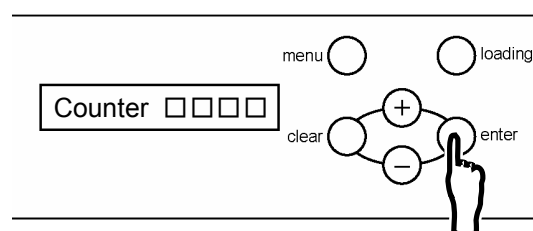

3. Press the **enter** button to come to the state which can reset print counter.

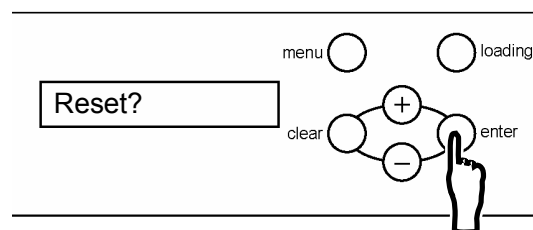

4. Press the **enter** button to reset print counter.  
\* Press the **clear** button when not resetting.

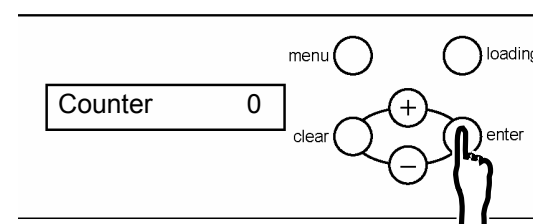

5. Press the **clear** button repeatedly until the ready state is displayed.

### 3.3.8 Setup of Plate Remains SW(on/off)

1. In the ready state, press the **menu** button once, press the **+** button until "Remains Sw" displays on the LCD.

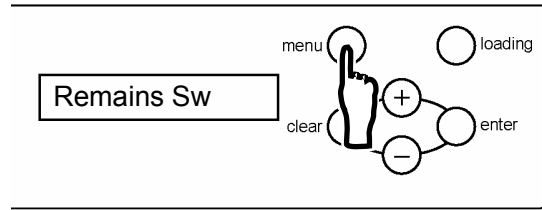

2. Press the **enter** button, and display the setting state (on/off) of "Remains SW" .

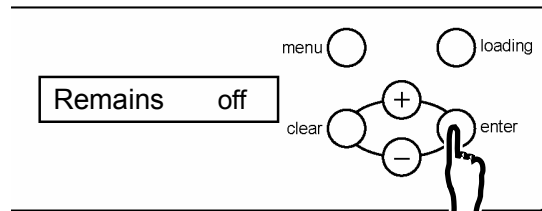

3. Press the **+** or **-** button to change the state (on/off) of "Remains SW".

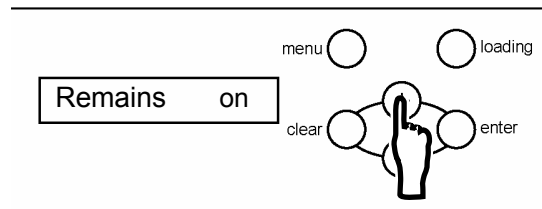

4. Press the **enter** button to confirm the setting of "Remains SW".

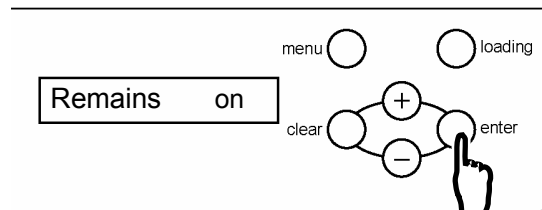

5. Press the **clear** button repeatedly until the ready state is displayed.

### 3.3.9 Execution of Platen Cleaning

Please use this mode when you clean-up a platen roller.  
Please refer to Chapter 4 about the cleaning method of the platen roller.

1. In the ready state, press the **menu** button once, press the **+** button until "Platen cleaning" displays on the LCD.

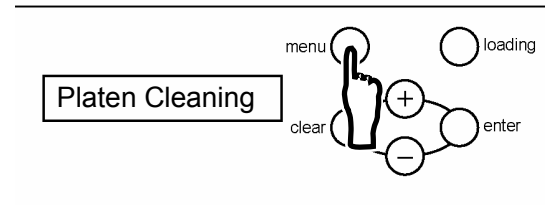

2. Press the **enter** button to select the operation for platen cleaning mode.

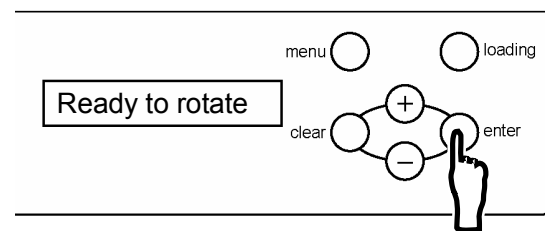

3. After closing Upper cover, press the **enter** button once, and a platen roller rotates 60 degrees.  
If you want to clean up a entire roller, please repeat this 6 times.

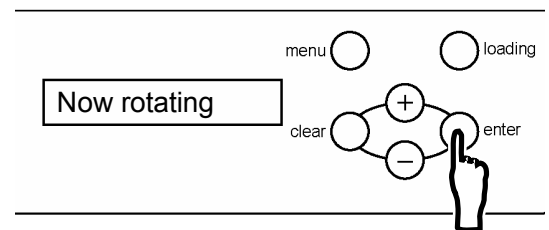

4. Press the **clear** button repeatedly until the ready state is displayed.

### 3.3.10 Setting the Pinch Cleaning Mode and Execution of Pinch Cleaning

This mode is used when pinch roller is cleaned.

After black bar with setup length is repeatedly printed at setup number of times, a plate feed for cleaning is executed. At setup number of times, and printed plate with black bar is cut and discharged.

#### ■ Setting the print length of black bar

Set up the print length of black bar print for pinch cleaning.

1. In the ready state, press the **menu** button once, press the **+** button until "Pinch Cleaning" displays on the LCD.

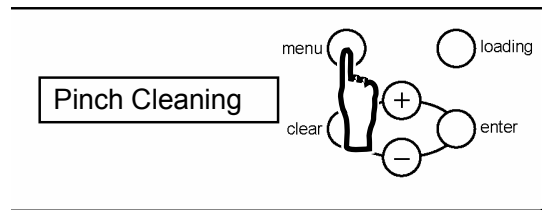

2. Press the **enter** button, and display "Print Length" on the LCD.

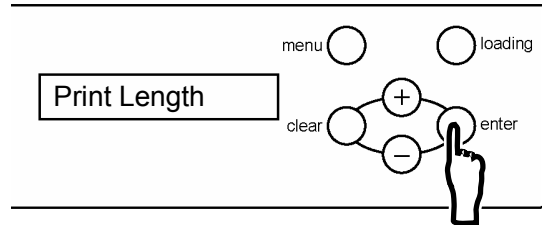

3. Press the **enter** button, and display the setting state of print length.

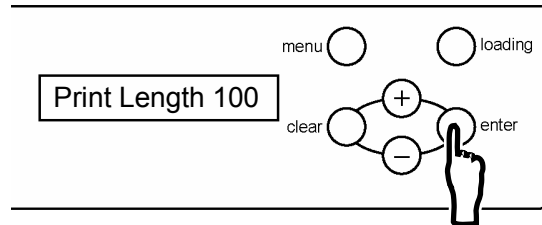

4. Press the **+** or **-** button to change the setting of the print length.

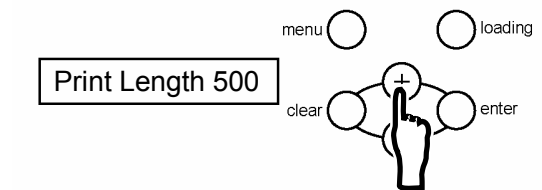

#### [Useful tip]

It can be set from 100mm to 500mm, **in increments of 1mm.**

When the setting value is enlarged, the effect of head cleaning becomes large, but cleaning time becomes long.



5. Press the **enter** button to confirm the setting of the print length.

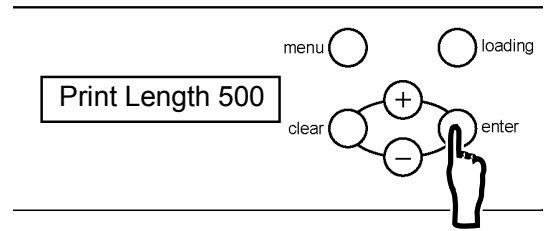

6. Press the **clear** button repeatedly until the ready state is displayed.

### ■ Setting the number of times for black bar print

Set the number of times to print black bar for pinch cleaning.

1. In the ready state, press the **menu** button once, press the **+** button until "Pinch Cleaning" displays on the LCD.

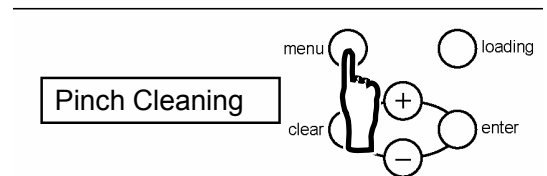

2. Press the **enter** button once, press the **+** button once, and display "Print Num" on the LCD.

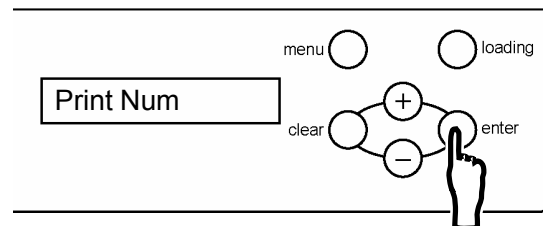

3. Press the **enter** button, and display the setting state of print number.

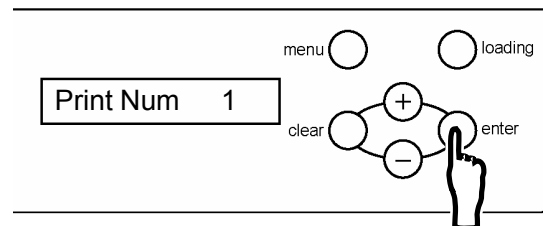

4. Press the **+** or **-** button to change the setting of the print number.

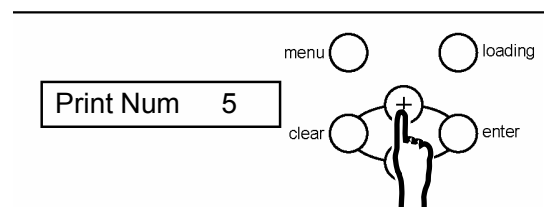

#### [Useful tip]

It can be set from 1 to 5, **in increments of 1**.

When the setting value is enlarged, the effect of head cleaning becomes large, but cleaning time becomes long.

- 5.** Press the **enter** button to confirm the setting of the print number.

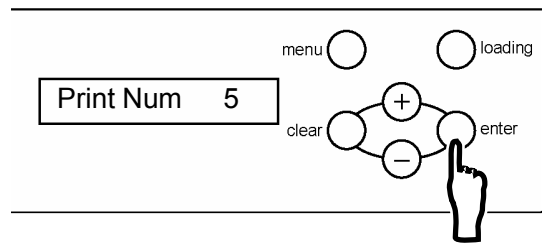

- 6.** Press the **clear** button repeatedly until the ready state is displayed.

**■ Setting the number of times for cleaning**  
Set up the number of times for cleaning (plate feed).

- 1.** In the ready state, press the **menu** button once, press the **+** button until "Pinch Cleaning" displays on the LCD.

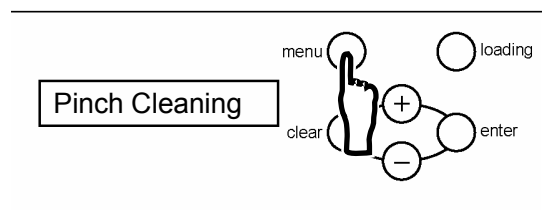

- 2.** Press the **enter** button once, press the **+** button until "Cleaning Nm" displays on the LCD.

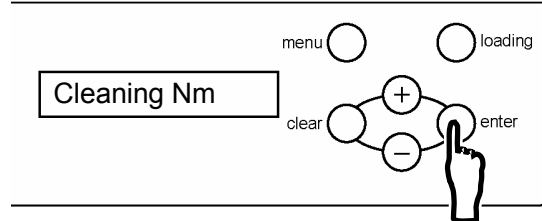

- 3.** Press the **enter** button, and display the setting state of cleaning number.

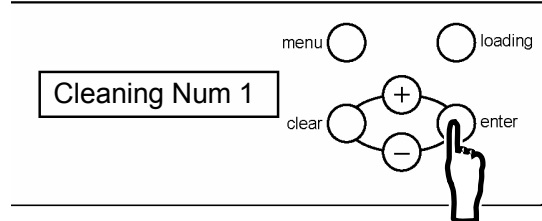

- 4.** Press the **+** or **-** button to change the setting of the cleaning number.

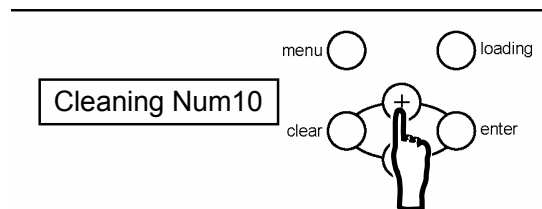

**[Useful tip]**

It can be set from 1 to 10, in increments of 1.  
When the setting value is enlarged, the effect of head cleaning becomes large, but cleaning time becomes long.

- 5.** Press the **enter** button to confirm the setting of the cleaning number.

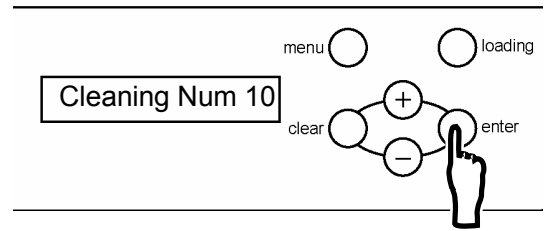

- 6.** Press the **clear** button repeatedly until the ready state is displayed.

### ■ Execution of Pinch cleaning

Pinch cleaning is executed.

- 1.** In the ready state, press the **menu** button once, press the **+** button until "Pinch Cleaning" displays on the LCD.

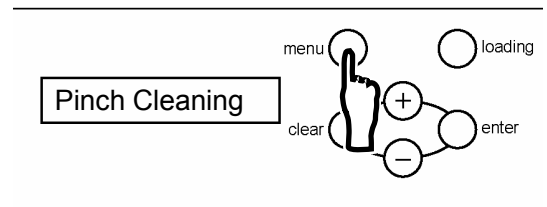

- 2.** Press the **enter** button once, press the **+** button until "Cleaning" displays on the LCD.

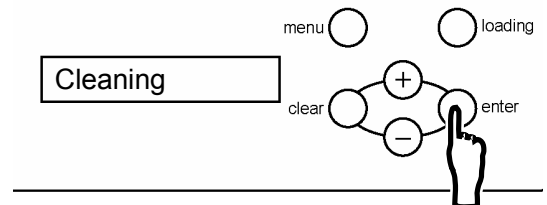

- 3.** Press the **enter** button to execute head cleaning.

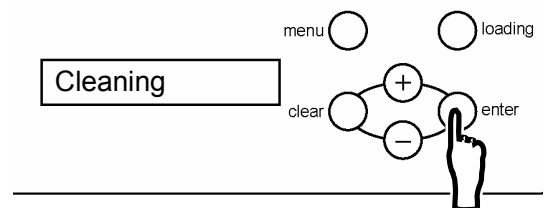

- 4.** Press the **clear** button repeatedly until the ready state is displayed.

### 3.3.11 Display of accumulated print distance

Displays accumulated print distance.

This message is displayed only when Manage Count Sw is set at ON (factory setting).

- 1.** In the ready state, press the **menu** button once, press the **+** button until "Manage Count" displays on the LCD.

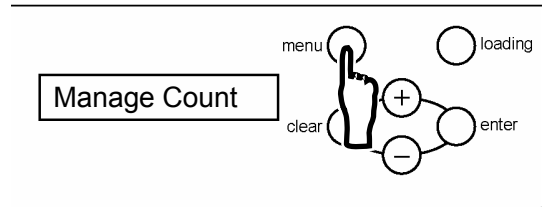

- 2.** Press the **enter** button to display "Manage Count"(accumulated print distance).

- In case of Millimeter mode, accumulated print distance is shown in meter.
- In case of Inch mode, accumulated print distance is shown in feet. (unit is omitted)

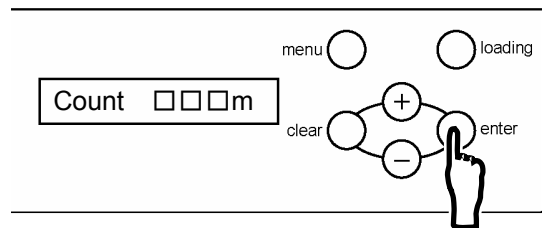

- 3.** Press the **clear** button repeatedly until the ready state is displayed.

### 3.3.12 Set up a print Interval

Printing is interrupted at the number that you input in this mode for cleaning a thermal head.

- The counter is reset automatically after you power down a machine even if print jobs don't reach the number that you input.
- When print jobs reach the number that you input, "Restart" is displayed on the LCD. Then you need to press a enter button to reset the counter.

1. In the ready state, press the **menu** button once, press the **+** button until "Interval Set" displays on the LCD.

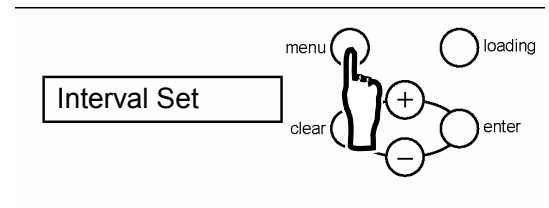

2. Press the **enter** button to display a setting state of "Interval Set".

- default setting is 0 (disable this mode)

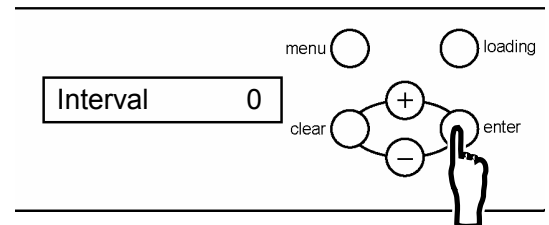

3. Press the **enter** button after input Interval setting.

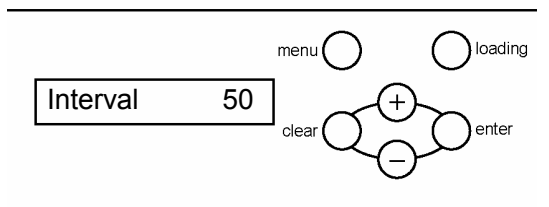

#### [Useful tip]

It can be set from 10 times to 500 times in increments of 10 times.

To change values, use the following buttons:

**menu** button: Increment the number by 100, **+** button: Increment the number by 10

**loading** button: Decrement the number by 100, **-** button: Decrement the number by 10

4. Press the **clear** button repeatedly until the ready state is displayed.

(MEMO)

# Chapter 4 Daily Maintenance

## 4.1 Cleaning the parts inside the Thermal Digiploter

To keep the best print quality, clean the thermal head, image sensor, head-position plate, platen roller, cleaning rollers, the main pinch roller and the feeding pinch roller by following the steps as instructed below. Please clean them at the following frequency.

- **Every day after finishing whole jobs**

- **Thermal head**

- Image with many halftone dots is apt to get it dirty, and there sometimes needs to be cleaned several times a day.

- **Once a week**

- **Main pinch roller**

- **Platen roller**

- **Feeding roller**

- **Cleaning rollers**

- **Once a month**

- **Image sensor**

- **Head-position plate**

### 4.1.1 Cleaning the thermal head

1. By holding the opening lever A on the top of the upper cover, open the upper cover.

<b>Note</b>
<b>Do not open the upper cover extremely quickly or forcibly 90 degrees or more.</b>

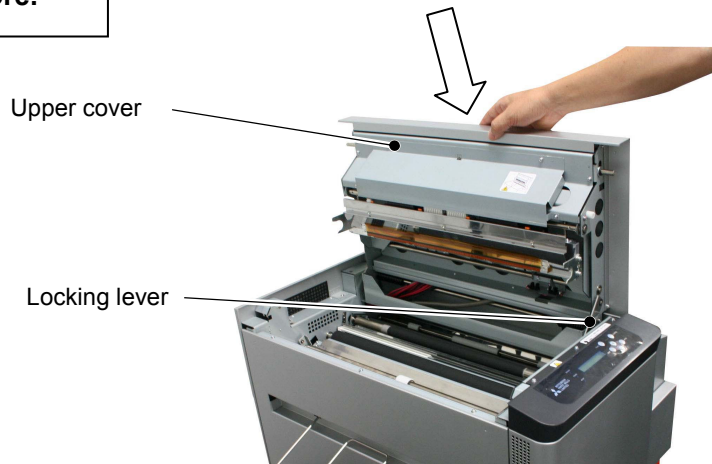
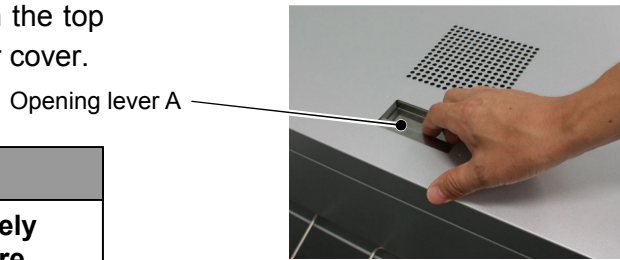

**[Useful tip]**

A locking lever is provided to the upper cover to prevent the cover from closing down. When opening the upper cover, be sure to open it to the position where the locking lever locks effectively.

2. Wipe the heating element (thin glassy band) of the thermal head with a recommended cleaning cloth soaked in the adequate amount of recommended cleaning fluid, applying it overall and uniformly, and moving it from side to side.

 <b>CAUTION</b>
<ul style="list-style-type: none"><li>◆ <b>The thermal head is hot just after printing. Do not touch it directly by hand.</b></li><li>◆ <b>Fingerprints on the thermal head heating element can cause the thermal head to fail. Do not touch it directly by hand.</b></li><li>◆ <b>Be careful not to be injured by protrusions in the Thermal Digiplate.</b></li></ul>

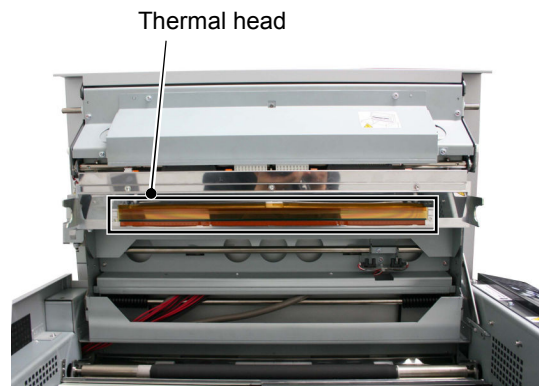



- 3.** Wipe the heating element of the thermal head with a rub small pieces of wrapping sheet (3M #4000), applying it overall and uniformly, and moving it from side to side.

The heating element

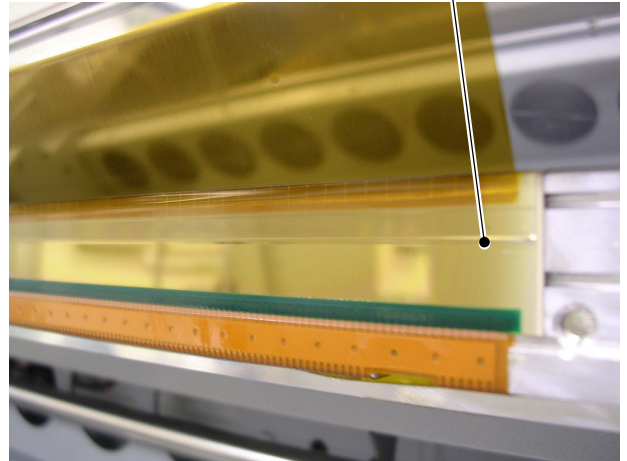

- 4.** Wipe the heating element with a recommended cleaning cloth soaked in the adequate amount of recommended cleaning fluid.

- 5.** Release the locking lever and close the upper cover slowly.

Upper cover

Locking lever



### 4.1.2 Cleaning the main pinch roller

1. By holding the opening lever A on the top of the upper cover, open the upper cover.

Note
Do not open the upper cover extremely quickly or forcibly 90 degrees or more.

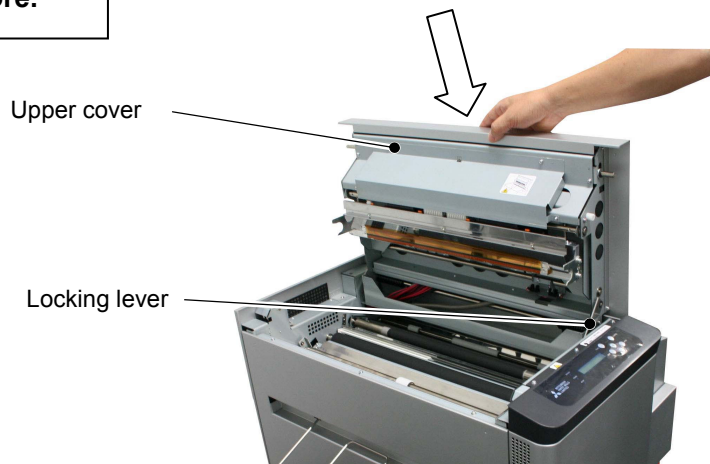
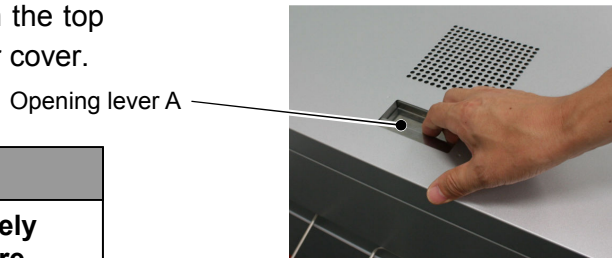

**[Useful tip]**

A locking lever is provided to the upper cover to prevent the cover from closing down. When opening the upper cover, be sure to open it to the position where the locking lever locks effectively.

2. When the plate is set, pull it out with your hands.

3. Wipe the main pinch roller with a recommended cleaning cloth soaked in the adequate amount of recommended cleaning fluid.

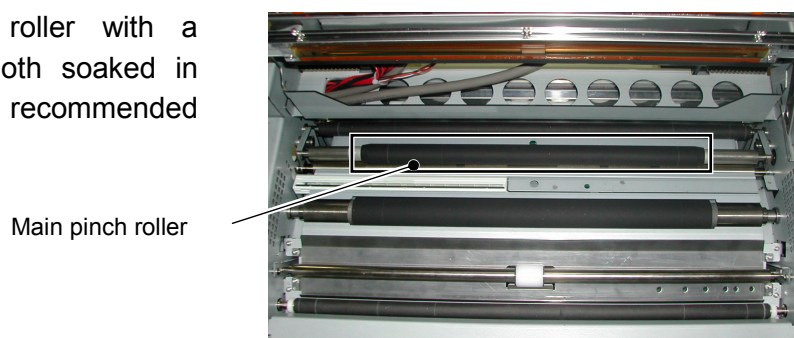

- 4.** Release the locking lever and close the upper cover slowly.



- 5.** Reset the plate.

### 4.1.3 Cleaning the platen roller

1. By holding the opening lever A on the top of the upper cover, open the upper cover.

Note
Do not open the upper cover extremely quickly or forcibly 90 degrees or more.

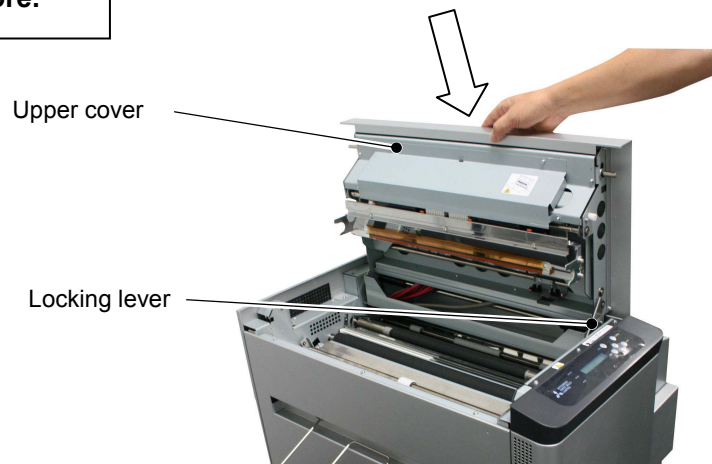
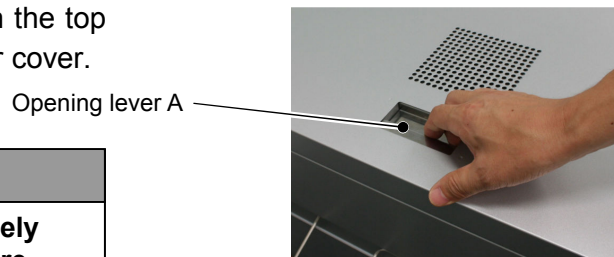

**[Useful tip]**

A locking lever is provided to the upper cover to prevent the cover from closing down. When opening the upper cover, be sure to open it to the position where the locking lever locks effectively.

2. When the plate is set, pull it out with your hands.

3. Wipe the rubber part of the platen roller with a recommended cleaning cloth soaked in the adequate amount of recommended cleaning fluid.

- Please rotate the platen roller using the function of "Platen cleaning mode" in the 3.3.9 section, and clean the entire circumferences of the rubber part.
- In order to clean the entire circumferences of the rubber part, it is necessary to repeat operation of "3." in the 3.3.9th section at least 6 times.

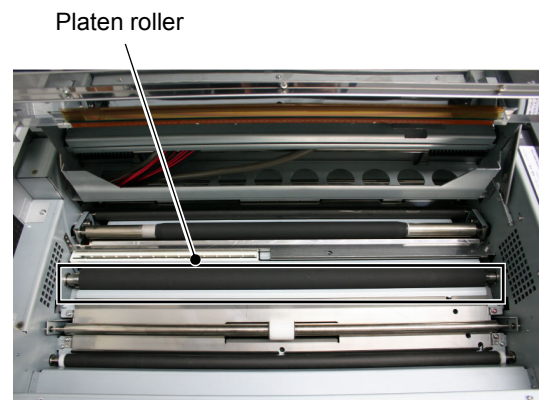

**⚠ CAUTION**

- ◆ Be careful not to scratch the rubber surface.
- ◆ Dirt on the platen roller can affect the print size accuracy.
- ◆ After cleaning, wait until recommended cleaning fluid has evaporated sufficiently before starting printing. (It is recommended that the Thermal Digiplate be left for about 5 minutes after cleaning.)
- ◆ Do not put your hand or cleaning cloth close to the inside of the Thermal Digiplate during the platen roller rotation.

- 4.** Release the locking lever and close the upper cover slowly.



- 5.** Reset the plate.

### 4.1.4 Cleaning the feeding pinch roller

1. By holding the opening lever A on the top of the upper cover, open the upper cover.

Note
Do not open the upper cover extremely quickly or forcibly 90 degrees or more.

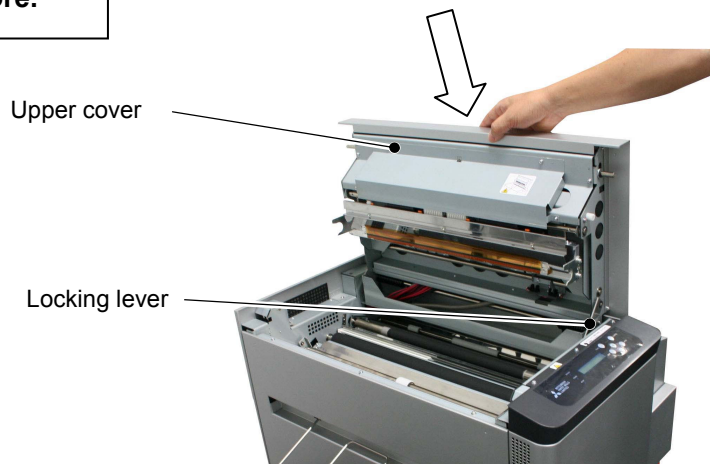
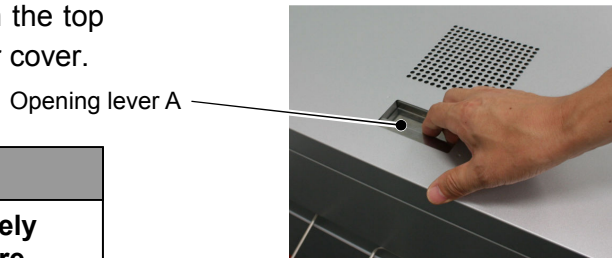

**[Useful tip]**

A locking lever is provided to the upper cover to prevent the cover from closing down. When opening the upper cover, be sure to open it to the position where the locking lever locks effectively.

2. When the plate is set, pull it out with your hands.

3. Remove the upper feeding roller, and wipe the white roller part with a recommended cleaning cloth soaked in the adequate amount of recommended cleaning fluid.

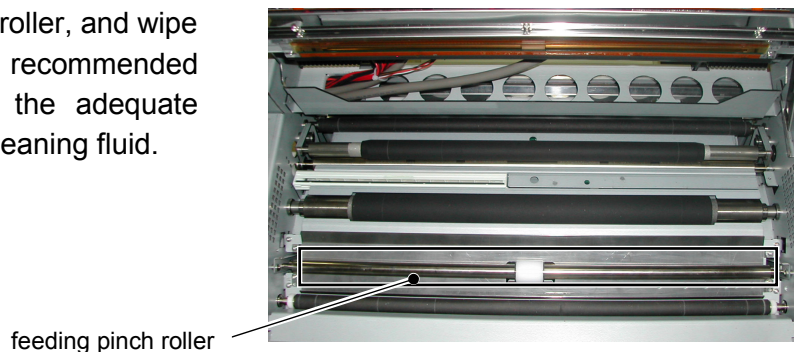

**4.** Wipe the rubber part of the bottom roller with a recommended cleaning cloth soaked in the adequate amount of recommended cleaning fluid.

- It's very difficult to rotate the bottom roller by hands, please use the function of "Platen cleaning mode" in the 3.3.9 section, and clean the entire circumferences of the rubber part.
- In order to clean the entire circumferences of the rubber part, it is necessary to repeat operation of "3." in the 3.3.9th section at least 6 times.

**5.** Release the locking lever and close the upper cover slowly.



**6.** Reset the plate.



### 4.1.5 Cleaning the cleaning rollers

1. By holding the opening lever A on the top of the upper cover, open the upper cover.

Note
Do not open the upper cover extremely quickly or forcibly 90 degrees or more.

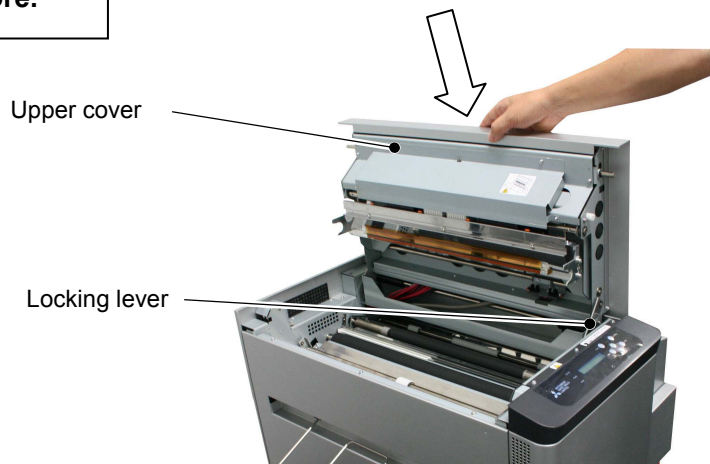
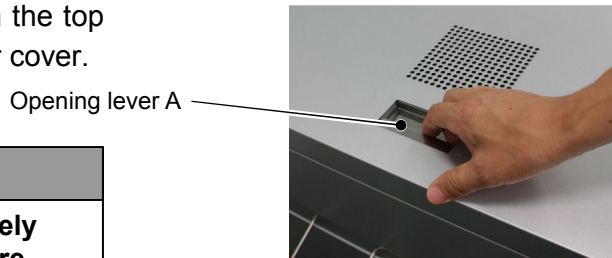

**[Useful tip]**

A locking lever is provided to the upper cover to prevent the cover from closing down. When opening the upper cover, be sure to open it to the position where the locking lever locks effectively.

2. When the plate is set, pull it out with your hands.

3. Wipe the cleaning rollers with a recommended cleaning cloth soaked in the adequate amount of recommended cleaning fluid.

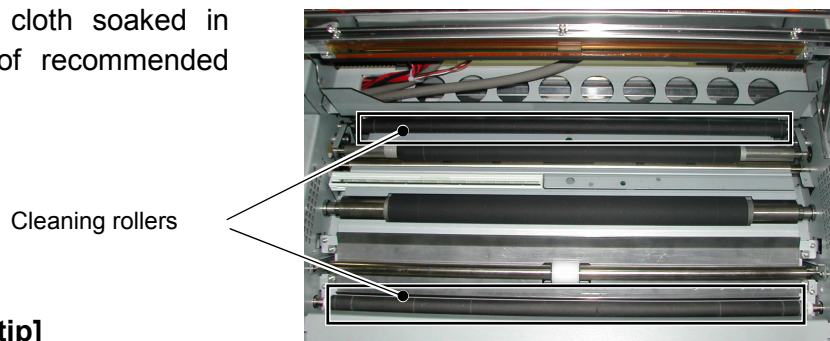

**[Useful tip]**

Cleaning rollers are provided on the entrance and discharge sides.



- 4.** Release the locking lever and close the upper cover slowly.



- 5.** Reset the plate.

## 4.1.6 Cleaning the image sensor

1. By holding the opening lever A on the top of the upper cover, open the upper cover.

Note
Do not open the upper cover extremely quickly or forcibly 90 degrees or more.

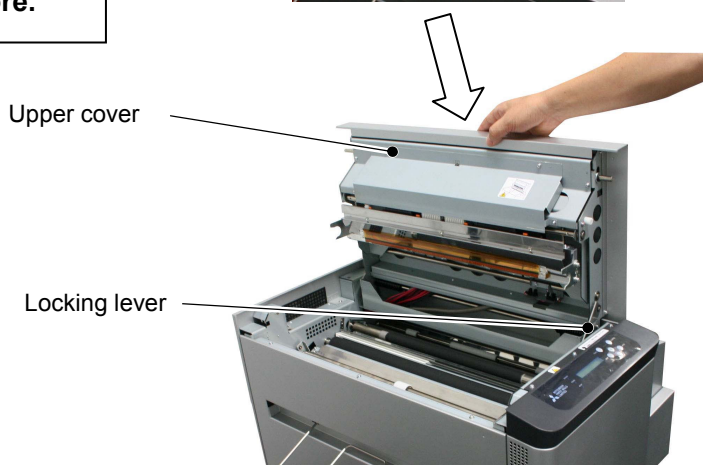
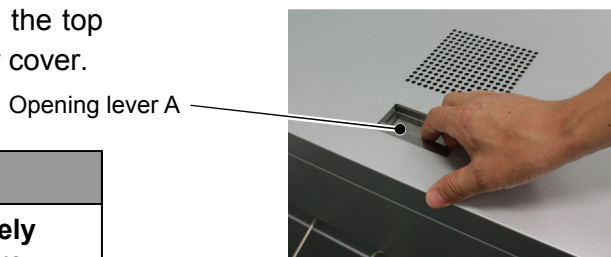

### [Useful tip]

A locking lever is provided to the upper cover to prevent the cover from closing down. When opening the upper cover, be sure to open it to the position where the locking lever locks effectively.

2. Wipe the image sensor with a recommended cleaning cloth soaked in the adequate amount of recommended cleaning fluid.

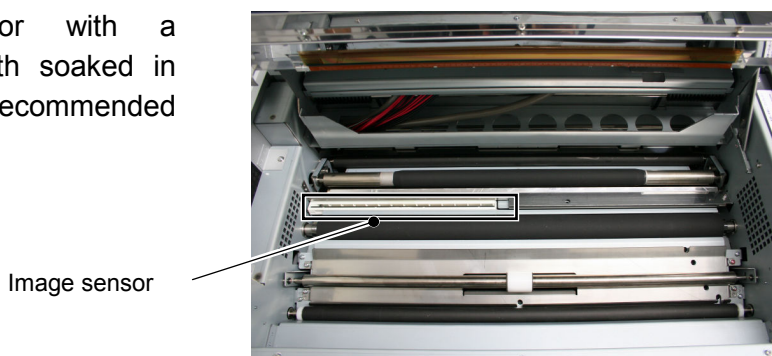

- 3.** Release the locking lever and close the upper cover slowly.



### 4.1.7 Cleaning the head position plate

1. By holding the opening lever A on the top of the upper cover, open the upper cover.

Note
Do not open the upper cover extremely quickly or forcibly 90 degrees or more.

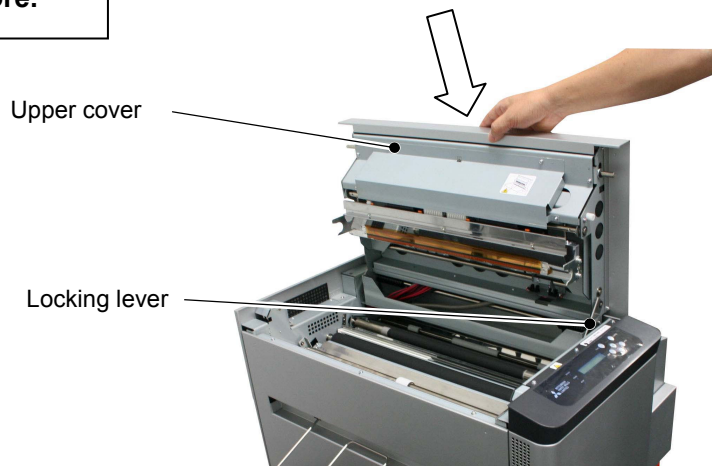
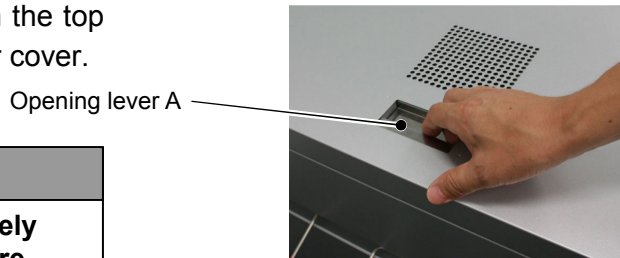

**[Useful tip]**

A locking lever is provided to the upper cover to prevent the cover from closing down. When opening the upper cover, be sure to open it to the position where the locking lever locks effectively.

2. Wipe the head-position plate with a recommended cleaning cloth soaked in the adequate amount of recommended cleaning fluid, applying it overall and uniformly, and moving it from side to side.

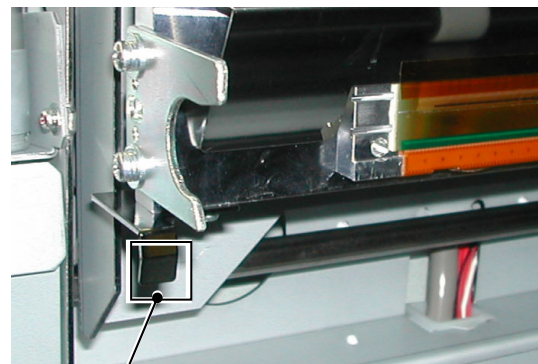

Head-position plate

- 3.** Release the locking lever and close the upper cover slowly.



## 4.2 Cleaning the cover of the Thermal Digiplater

To remove dirt, wipe the cover of the Thermal Digiplater with a dry soft cloth.

If dirt cannot be removed by wiping with a dry cloth, lightly wipe the cover with a dampened cloth which has been soaked in water or a little diluted neutral detergent.

### WARNING

Should any foreign matter (metallic fragments, water or liquids) gets into the Thermal Digiplater, turn off the power switch, disconnect the power cable from the electric outlet, and contact the distributor.  
Using the Thermal Digiplater without removing the foreign matter can cause a fire or electric shock.

### WARNING

Should the Thermal Digiplater be used in an abnormal state (generating heat, smoking or abnormal odors), it can cause a fire or electric shock. Turn off the power switch immediately, disconnect the power cable from the electric outlet and contact the distributor.

### CAUTION

If the surfaces are wiped with a volatile liquid, such as benzine or thinner, or sprayed with insecticide, they can become discolored or cracked.

## 4.3 Cleaning the filters

If it gets dust on the vent holes and filters, clean them with a vacuum cleaner.

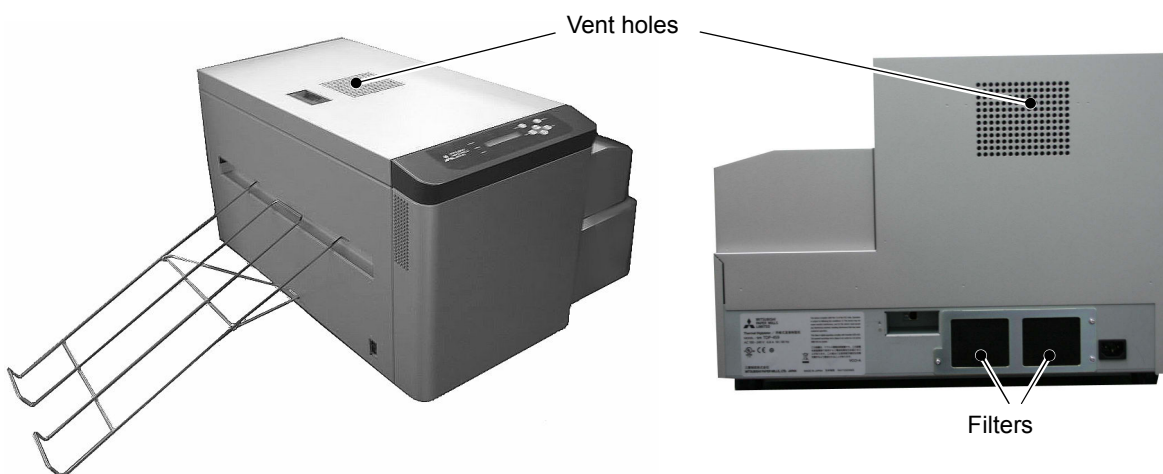

## 4.4 Consumable parts

Consumable parts for the Thermal Digiploter are shown on the following table.

No.	Name
1	Thermal head(Assembly)
2	Cleaning roller
3	Cutter unit
4	Filter

\*Available supply period for consumable parts is 5 years after it is discontinued.

\*It will be informed separately about discontinuing the product.

(MEMO)



# Chapter 5 Trouble shooting

## 5.1 When an error message is displayed

When an error occurs, an error message will be shown on the LCD on the operation panel. The error messages shown on the LCD and the measures to be taken are explained below.

Message on the LCD	Condition	Measures
Plate Empty	The plate has been used up or no plate has been installed.	If the plate has been used up, supply with a new plate.
No Plate	The plate is not set.	Please set the plate.
Unmatch Plate	The size of the plate placed in this machine does not match the plate size set.	Check the size of the actual plate and the plate size set on this machine. Then install and set the correct plate.
Plate Jam □□ *	Plate jam	Remove the jammed plate. If plate jams occur frequently, consult Service department.
Mecha Error □□ *	Problem in the mechanical system of the Thermal Digiplate	Turn the power to the Thermal Digiplate off and on. If the Thermal Digiplate cannot be restored by turning the power off and on, it may be necessary to repair the Thermal Digiplate. Consult Service department.
Control Error □□ *	Problem in the control board of the Thermal Digiplate	
Temp Sens Err □□ *	A temperature sensor of the Thermal Digiplate is defective.	
Sensor Error □□ *	Problem in the sensor system of the Thermal Digiplate	

- \* The messages on the LCD show a code number for service in the boxes (□□). When consulting Service department, please quote a code number.

## 5.2 Plate jam

If a plate jam occurs, turn off the power and remove the jammed plate.

1. Turn off the power switch.



2. By holding the opening lever A on the top of the upper cover, open the upper cover to check the plate condition.  
If there is no plate left, go to ■ When there is no plate left (page 69).  
If there is plate left, go to ■ When there is plate left (page 70).

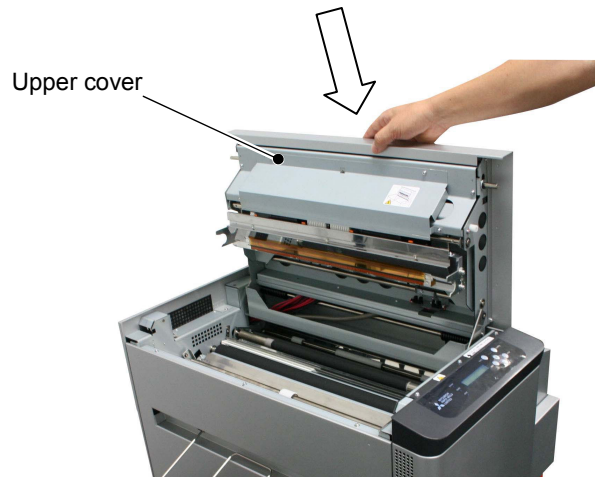
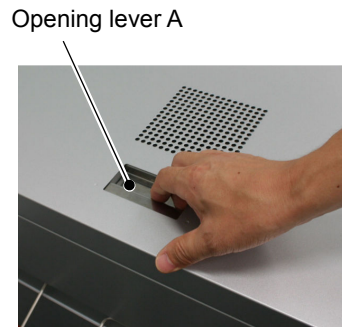

Note
Do not open the plate cover extremely quickly or forcibly 90 degrees or more.

 CAUTION
<ul style="list-style-type: none"><li>♦ The thermal head is hot just after printing. Do not touch it directly by hand.</li><li>♦ Fingerprints on the thermal head heating element can cause the thermal head to fail. Do not touch it directly by hand.</li><li>♦ Be careful not to be injured by protrusions in the Thermal Digiplate.</li></ul>

■ **When there is no plate left**

**1.** Turn on the power switch.



**2.** Reset the plate.  
See **2.8 Setting the plate.**

■ **When there is plate left**

- 1.** Open the plate cover and pull the plate out with your hands.

Note
<b>Do not open the plate cover extremely quickly or forcibly 90 degrees or more.</b>

Plate



- 2.** If the plate cannot be pulled out, cut off the jammed and folded sections with scissors, and pull the plate out.



- 3.** Reset the plate.  
See **2.8 Setting the plate.**

## 5.3 When parts of image area are missing from the printed plate

### ■ Incorrect print with straight streaky missing parts in the direction of plate feed

- ◆ This may have been caused by contamination on the thermal head. Clean it as instructed in Chapter 4 , 4.1 Cleaning the parts inside the Thermal Digiplate.
- ◆ If this problem cannot be solved by cleaning, the head may be broken. Consult Service department.

### ■ Incorrect print with dotted missing parts

- ◆ This may have been caused by contamination on the cleaning rollers. Clean them as instructed in Chapter 4 , 4.1 Cleaning the parts inside the Thermal Digiplate.

## 5.4 Plate is not correctly detected

- The error message “Plate Empty” is displayed when the plate has not been used up.

Contaminated plate sensors may not have correctly detected the plate. Clean the plate sensors by following the steps as instructed below.

If this problem cannot be solved by cleaning, the sensors may be defective. Consult Service department.

1. Turn off the power switch.



2. By holding the opening lever A on the top of the upper cover, open the upper cover.

Note
Do not open the upper cover extremely quickly or forcibly 90 degrees or more.

 CAUTION
<ul style="list-style-type: none"><li>• The thermal head is hot just after printing. Do not touch it directly by hand.</li><li>• Fingerprints on the thermal head heating element can cause the thermal head to fail. Do not touch it directly by hand.</li><li>• Be careful not to be injured by protrusions in the Thermal Digiplate.</li></ul>

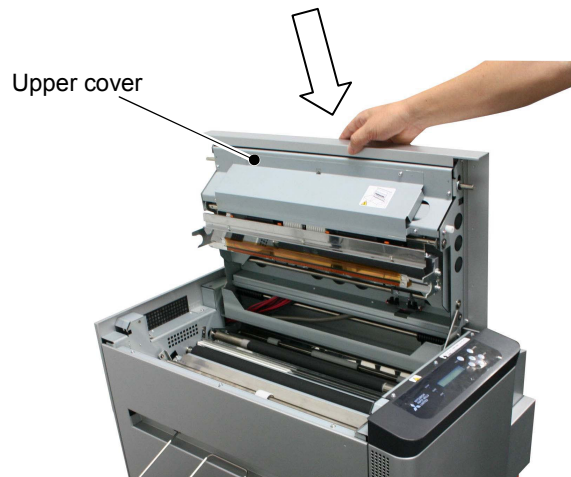
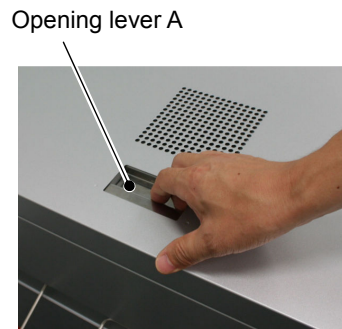

### [Useful tip]

A locking lever is provided to the upper cover to prevent the cover from closing down. When opening the upper cover, be sure to open it to the position where the locking lever locks effectively.

3. Wipe the plate sensors with a recommended cleaning cloth soaked in the adequate amount of recommended cleaning fluid.



**[Useful tip]**

Insert the cotton swab into each of the eight holes, as indicated in the circles in the above photo, and wipe off contamination by moving the cotton swab in a circular pattern in the hole.

4. Release the locking lever to slowly close the upper cover.

 <b>CAUTION</b>
<b>Be careful not to catch fingers when closing the upper cover.</b>



## 5.5 When power is off during printing

- ♦ Power outage
- ♦ Power cable accidentally disconnected

If power is off during printing, the thermal head remains pressed to the platen roller. Leaving this condition uncorrected for an extended period may cause deformation of the rubber on the platen roller. To prevent the rubber from being deformed, perform the following steps as instructed below.

- 1.** Turn off the power switch and restore the power supply.

**[Useful tip]**

In case of a power outage, wait until the power supply service is restored. If the power cable is disconnected, re-connect the power cable to the power supply terminal or the electric outlet.

**CAUTION**

When power is off during printing, the thermal head remains pressed to the platen roller and it is hard to put opening lever A and upper cover in motion. Put them in motion more strongly than usual.

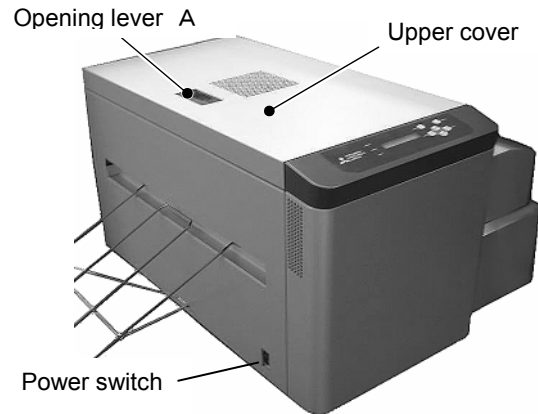

- 2.** Turn on the power switch.

**CAUTION**

When turning on the power switch and the ready state is not displayed, it is thought that upper cover is not closed completely. Push the corners of the upper cover strongly (see the photo on the right) until clicking noise can be heard.

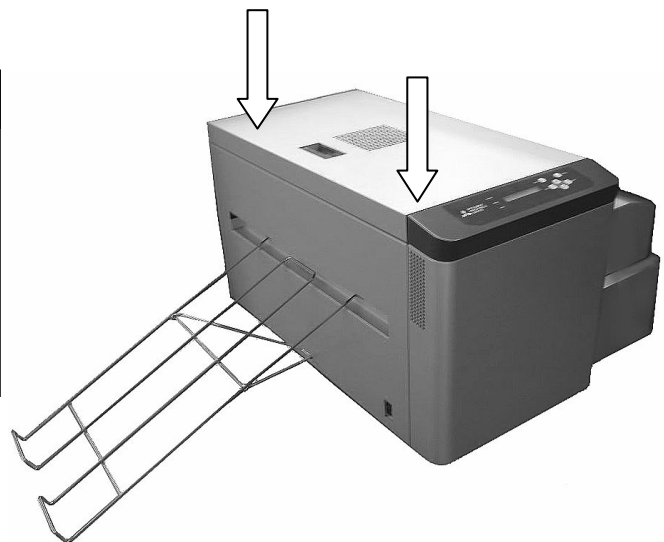

- 3.** If "Plate Jam" is displayed on the LCD on the operation panel, follow the instructions as described in 5.2 Plate jam.



## **Chapter 6 After-sales service**

If you would like to inquire about the product or request a repair, please consult the distributor from whom you bought the product.

(MEMO)

# Chapter 7 Specification

## 7.1 Basic specification

Item	Specification
Print system	Direct thermal system
Resolution	1203.8 DPI Dot pitch for crosswire direction : 0.0211mm Dot pitch for lengthwise direction : 0.0211mm
Plate size	(Width) 279,286,292,305,310,318,324(mm) 11.00,11.25,11.5,12.00,12.19,12.50,12.75(inch) (Length) 150-530(mm)
Maximum recording width	360mm
Print speed	Less than 45 seconds * Plate size 324mm x 492mm(12.7inch x 19.3inch) * In case of 20°C (68°F)with ambient temperature
Plate tray capacity	5 plates
Buffer memory capacity	64M byte(for 1 image)
Interface	USB2.0(High speed)
Power supply	AC90~264V automatic change
Power consumption	Maximum power consumption less than 610W Standby power consumption less than 35W
Use environment	Temperature20~30°C(68-86°F), Humidity50~70% (No condensation)
Dimension	Height 383mm×Width 515mm×Depth 663mm (Body)
Weight	Approx 55kg(Body)

- Specification for this machine is subject to change without notice continual improvements.
- In case of TDP-324B, a width of 254mm (10.00 inch) is available additionally.

## 7.2 Outline figure

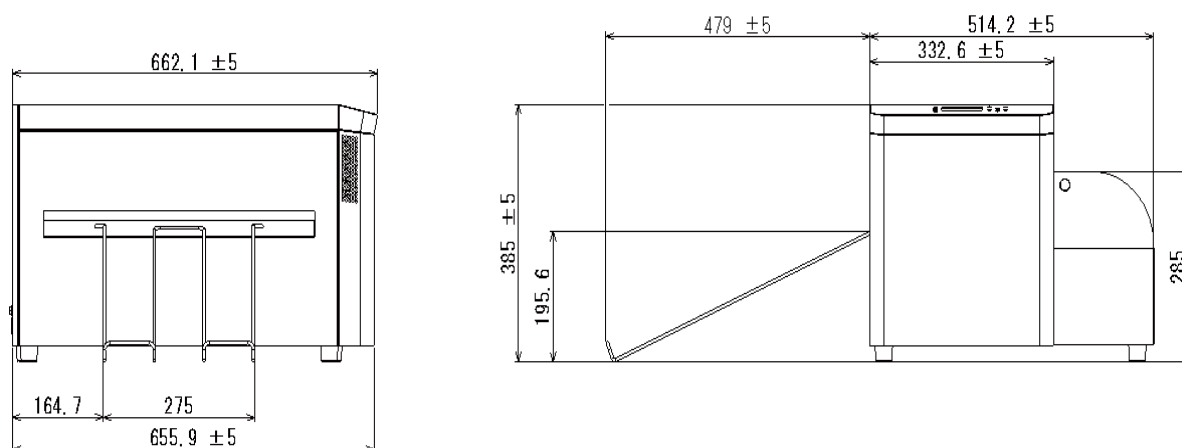

(MEMO)